

**RICOH PRIPORT VT 2000 SERIES**  
**(VT2100/2130/2150/2300/2500)**

**SERVICE MANUAL**

**SECTION 1**

**OVERALL MACHINE  
INFORMATION**

# 1. SPECIFICATIONS

---

## VT2300/VT2500

Configuration:	Desktop		
Master processing:	Digital		
Printing process:	Full automatic one drum stencil system		
Original type:	Sheet		
Original size:	Maximum 307 mm x 432 mm (12.0" x 17.0") Minimum 90 mm x 140 mm (3.6" x 5.5")		
Reproduction ratios:	3 Enlargement and 3 Reduction		
		LT Version	A4 Version
Enlargement		141%	141%
		127%	122%
		115%	115%
Full Size		100%	100%
Reduction		93%	93%
		75%	82%
		64%	71%
Image mode:	Line/Photo		
Color Printing:	Drum Unit replacement system		
Master feed/eject:	Roll master automatic feed/eject		
Printing area:	Maximum: 250 mm x 350 mm (9.8" x 13.7") at 20°C/ 65 % RH.		
Leading edge margin:	10 ± 3 mm at "0" position		
Print paper size:	Minimum: 90 mm x 148 mm (3.6" x 5.8") Maximum: 325 mm x 447 mm (12.8" x 17.6")		
Print paper weight:	50 g/m <sup>2</sup> to 215 g/m <sup>2</sup>		
Printing speed:	60, 75, 90, 105, 120 sheets/minute (5 steps)		

First print time:	34.5 seconds (B4 size) 31.5 seconds (A4 Size)
Paper feed table capacity:	1000 sheets (66.3 g/m <sup>2</sup> /17.6 lb)
Paper delivery table capacity:	500 sheets (66.3 g/m <sup>2</sup> / 17.6 lb)
Power source:	110V, 60 Hz ..... 6.0A 120 V, 60 Hz ..... 5.5 A 220/240 V, 50/60 Hz ..... 2.7 A
Power consumption:	110/120 V version: 430 W 220/240 V version: 470 W
Weight:	120 V version: 102 kg (224.8 lb) 220/240 V version: 107 kg (235.8 lb) Optional Table: 26 kg (57.3 lb)
Dimensions: (W x D x H)	Stored: 735 mm x 607 mm x 577 mm (29.0" x 23.9" x 22.8") Set up: 1279 mm x 607 mm x 656 mm (50.4" x 23.9" x 25.9") Table: 640 mm x 570 mm x 455 mm (25.2" x 22.4" x 17.9")
ADF original capacity:	20 sheets (66 g/m <sup>2</sup> ) or 1.8 mm height
Original guide width settings:	98 mm to 316 mm (38.6" to 12.44")
Original scanning time:	3 ms/1 line
Original thickness:	0.05 mm to 0.8 mm
Original feed speed:	20.8 mm/second (When master processing) 41.7 mm/second (When not master processing)
Pixel density:	16 dots/mm
Master eject box capacity:	25 masters (Normal condition) 20 masters (10°C/30% RH Condition)
Paper feeding:	Friction roller/center separation system

Feed table side plate width settings:	88 mm to 330 mm (3.46" to 12.99")	
Paper feed roller pressure:	Normal position.....	250 g
	Thick paper position.....	550 g
Separation roller pressure:	Normal position.....	180 g
	Weak position .....	70 g
Side registration:	± 10 mm (manual)	
Vertical registration:	± 20 mm (mechanical)	
Ink Supply:	Automatic ink supply system	
Press roller pressure:	10 ± 0.3 kg	
Paper Delivery:	Air knife/vacuum delivery	
Delivery side plate width settings:	80 mm to 320 mm (3.15" to 12.6")	
Print counter:	7 digits	
Master counter:	6 digits	
Supplies:		
Priport Master VT-M: (16 dots/mm)	Thermal master	280 mm width
	Master roll	250 masters/1 roll
	Roll diameter	130 mm
	Master length	480 mm/1 master
	Max run length	2000 prints
Ink Colors: (500 cc/pack)	Black, Red, Blue, Green, Brown	

**VT2100 Series (VT2100, VT2130, VT2150)**

Configuration:	Desk top
Master processing:	Digital
Printing process:	Full automatic one drum stencil system
Original type:	Sheet
Original size:	Maximum 307 mm x 432 mm (12.0" x 17.0")
Reproduction ratios:	LT version: 100 %, 93 %, 75 %, 64 % A4 version: 100 %, 93 %, 82 %, 71 %
Image mode:	Line/Photo
Color printing:	Drum unit replacement system
Master feed/eject:	Roll master automatic feed/eject
Master processing area:	VT2100: Maximum 256 mm x 354 mm (10.1" x 13.9") VT2130: Maximum 216 mm x 354 mm (8.5" x 13.9") VT2150: Maximum 216 mm x 287 mm (8.5" x 11.3")
Printing area:	VT2100: Maximum 250 mm x 350 mm (9.8" x 13.7") at 20°C/65 % RH VT2130: Maximum 210 mm x 350 mm (8.3" x 13.7") at 20°C/65% RH VT2150: Maximum 210 mm x 283 mm (8.3" x 11.1") at 20°C/65% RH
Leading edge margin:	10 mm
Print paper size:	Minimum 90 mm x 148 mm (3.6" x 5.8") Maximum 297 mm x 442 mm (11.6" X 17.4")
Print paper weight:	50 g/m <sup>2</sup> to 215 g/m <sup>2</sup>
Print speed:	60, 75, 90, 105, 120 sheets/minute (5 steps)
First print time:	VT2100: 35 seconds (B4 size) VT2130: 35 seconds (LG size) VT2150: 31 Seconds (A4 size)

Paper feed table capacity	1000 sheets (66.3 g/m <sup>2</sup> / 17.6 lb)
Paper delivery table capacity:	500 sheets (66.3 g/m <sup>2</sup> / 17.6 lb)
Power source:	220/240V, 50/60 Hz ..... 2.7A 120V, 60 Hz ..... 5.5 A 110V, 60 Hz ..... 6.0 A
Power consumption:	110/120 V version: 430 W 220/240 V version: 470 W
Weight:	110/120 V version: 100 kg (220.4 lb) 220/240 V version 105 kg (233.7 lb) Optional table: 26 kg (57.3 lb)
Dimensions: (W x D x H)	When stored: 735 mm x 607 mm x 569 mm (29.0" x 23.9" x 22.4") When set up: 1279 mm x 607 mm x 656 mm (50.4" x 23.9" x 25.9") Table only: 640 mm x 570 mm x 455 mm (25.2" x 22.4 x 17.9")
Original guide width-settings:	98 mm to 316 mm (38.6" to 12.44")
Original scanning time:	3 ms/1 line
Original thickness:	0.06 mm to 0.5 mm
Original feed speed:	20.8 mm/second
Pixel density:	16 dots/mm
Master eject box capacity:	25 masters (at normal conditions) 20 masters (at 10°C/30 % RH)
Paper feeding:	Friction roller/center separation system
Feed table side plate width settings:	88 mm to 317 mm (3.46" to 12.48")
Paper feed roller pressure:	Normal position ..... 250 g Thick paper position..... 550 g
Separation roller pressure:	Normal position..... 180 g Weak position ..... 70 g

Side registration:	±10 mm (manual)
Vertical registration:	±20 mm (mechanical)
Paper table raising / lowering speed:	22 mm/second (50 Hz) 26 mm/second (60 Hz)
Ink supply:	Automatic ink supply system
Pressure roller pressure:	10 ± 0.3 kg
Paper delivery:	Air knife/vacuum delivery
Delivery side plate width settings:	80 mm to 320 mm (3.15" to 12.6")
Print counter:	7 digits
Master counter:	6 digits

Supplies:

Priport Master VT-M for VT2100:		
(16 dots/mm)	Thermal master	280 mm width
	Master roll	250 masters/1 roll
	Master length	480 mm/1 master
	Max run length	2000 prints

Priport Master VT-S for VT2130/VT2150:		
	Thermal master	240 mm width
	Max run length	2000 prints

VT2130:	Master roll	250 masters/1 roll
	Master length	480 mm/1 master

VT2150:	Master roll	300 masters/1 roll
	Master length	413 mm/1 master

Ink:	500 cc ink pack
Colors:	Black, Red, Blue, Green, Brown



— MEMO —

## 2. GUIDE TO COMPONENTS AND THEIR FUNCTIONS

(Paper Feed Side)

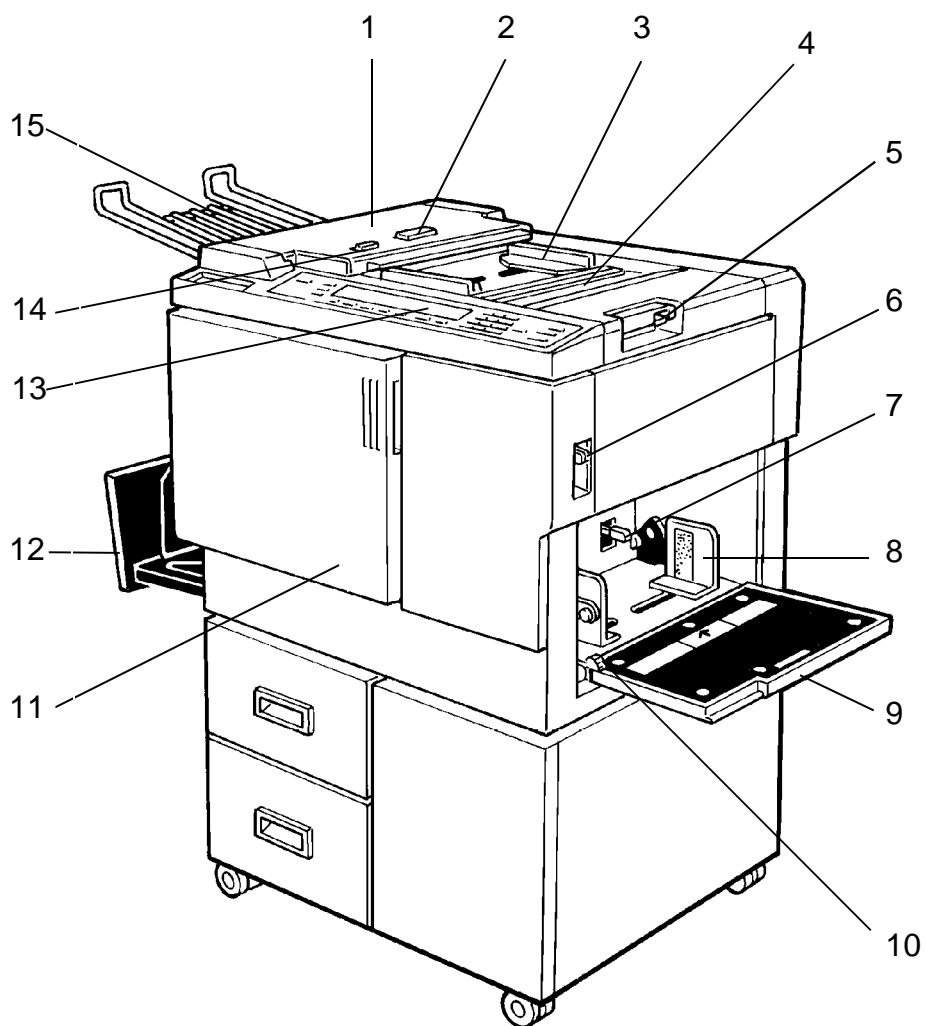

No.	Name	Function
1.	ADF Unit (VT2300/2500)	Feeds the original to the printing position automatically.
2.	ADF Unit Open Button (VT2300/2500)	Use to open the ADF unit.
3.	Original Guides	Adjust these guides to position the originals correctly.
4.	Original Table	Place the originals on this table.
5.	Original Table Release Lever	Use to open the original table unit to the left for master installation.
6.	Feed Roller Pressure Lever	Use to adjust the contact pressure of the paper feed roller according to paper thickness.
7.	Separation Roller Pressure Lever	Use to adjust the separation roller pressure to prevent double feed.
8.	Paper Feed Side Plate	Use to prevent paper skew.
9.	Paper Feed Table	Set the paper on this table.
10.	Side Plate Fine Adjusting Dial	Use to shift the paper feed table sideways.
11.	Front Door	Open for access to the inside of the machine.
12.	Paper Delivery Table	Completed prints are delivered here.
13.	Operation Panel	Operator controls and indicators are located here.
14.	ADF On/Off Select Switch (VT2300/2500)	When setting originals one sheet at a time, set this switch to the Off position.
15.	Original Tray	Originals used to make a master are delivered to this tray.

**(Paper Delivery Side)**

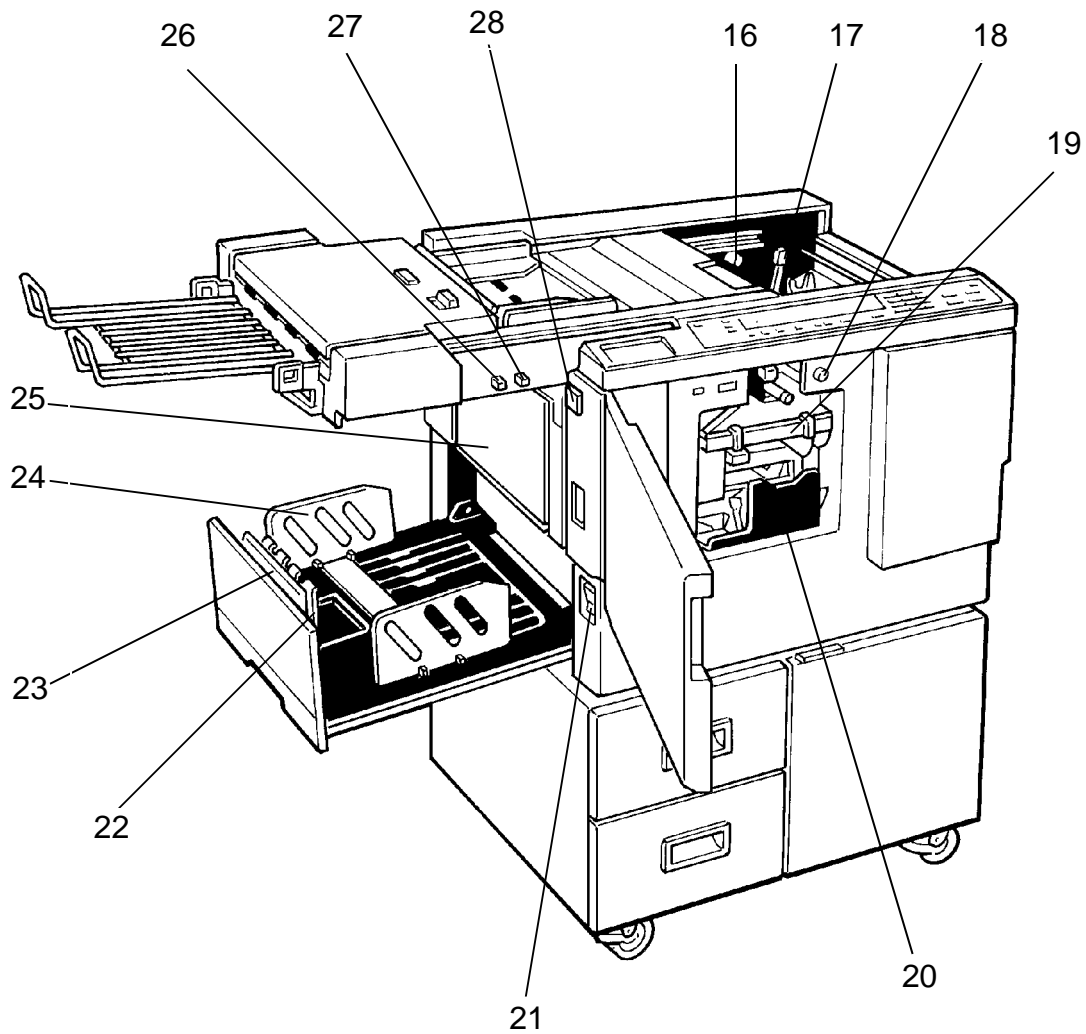

<b>No.</b>	<b>Name</b>	<b>Function</b>
16.	Master Cut Button	Press this button to cut the master paper leading edge after installing a new master roll.
17.	Pressure Release Lever	Use to install the master roll, or to clean the thermal head.
18.	Drum Rotating Button	Press to replace the drum or to remove misfed paper.
19.	Drum Unit	The master paper is wrapped around this unit.
20.	Ink Holder	Set the ink cartridge in this holder.
21.	Main Switch	Use to turn the power on or off.
22.	Small Size Paper Delivery End Plate (for smaller than A4/LT)	Use to align the leading edge of small-sized (less than A4/LT) prints.
23.	Paper Delivery End Plate (for larger than A4/LT)	Use to align the leading edge of prints larger than A4/LT.
24.	Paper Delivery Side Plate	Use to align the prints on the paper delivery table.
25.	Master Eject Container Cover	Open when removing the master eject container.
26.	Memory/Class switch (VT2300/2500)	Use to select memory or class mode.
27.	Skip Paper Feed Switch (VT2300/2500) Printing Density Select Switch (VT2100/2130/2150)	Use to adjust paper feed interval or a misted master. Use to select the printing density according to the type and quality of the original.
28.	Master Eject Unit Open Button	Press to remove misfed paper or a misfed master.

## 3. OPERATION PANEL

### VT2300/VT2500

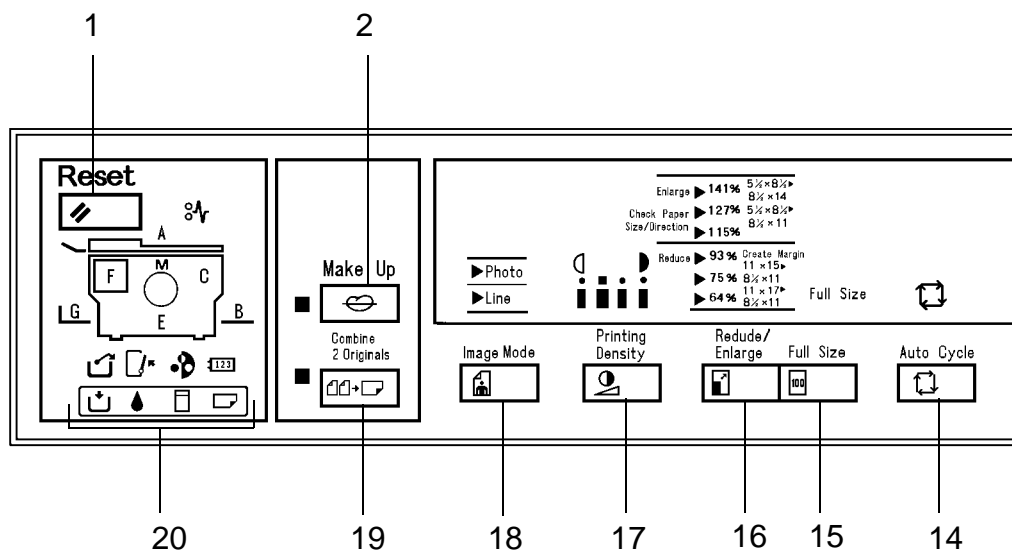

1. **Reset Key** Press to reset error indicators.
2. **Make-up Key** Press to use the make-up function (VT2500 only).
3. **Number Keys** Press to enter the number of prints.
4. **Stop Key** Press to stop the machine operation. The machine will continue operation when the Print Start key or Master Making key is pressed.
5. **Clear Modes Key** Press to cancel all previously entered settings and modes.
6. **Master Making Key** Press to make a master.
7. **Print Start Key** Press to start printing.
8. **Proof Key** Press to make trial prints or extra prints.
9. **Clear Key** Press to change the number set in the counter. Also use to change the make-up mode (VT2500 only). This key can be used only after the machine stops operation.
10. **Memory/Class Key** Use to select group printing in Memory mode or Class mode.
11. **Lower Paper Feed Table Key** Press to lower the paper feed table.
12. **Image Position Keys** Press to shift the image forwards or backwards on the print paper.

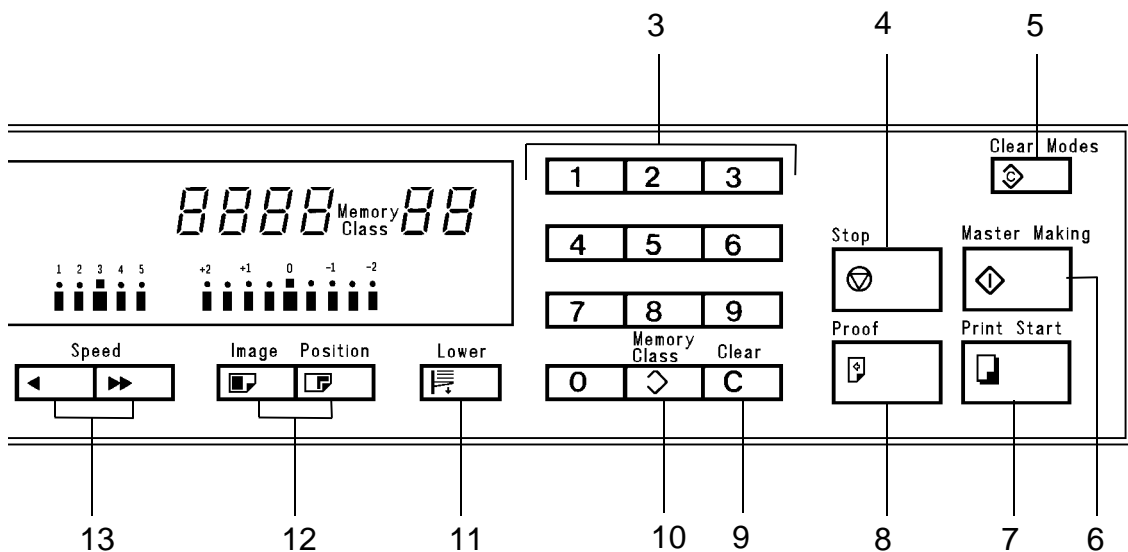

### 13. Speed Keys

Press to adjust the rotation speed of the machine according to the type of image and printing paper.

### 14. Auto Cycle Key

Use to automatically process masters and make prints.

### 15. Full Size Key

Press to make prints the same size as the original.

### 16. Reduce/Enlarge Key

Press to reduce or enlarge the image.

### 17. Printing Density Key

Press to make prints darker or lighter.

### 18. Image Mode Key

Press to select line mode or photo mode according to the type and quality of the original.

### 19. Combine 2 Originals Key

Press to combine two originals onto one print image.

### 20. Monitors

Light or blink when a non-standard condition occurs within the machine.

# VT2100/VT2130/VT2150

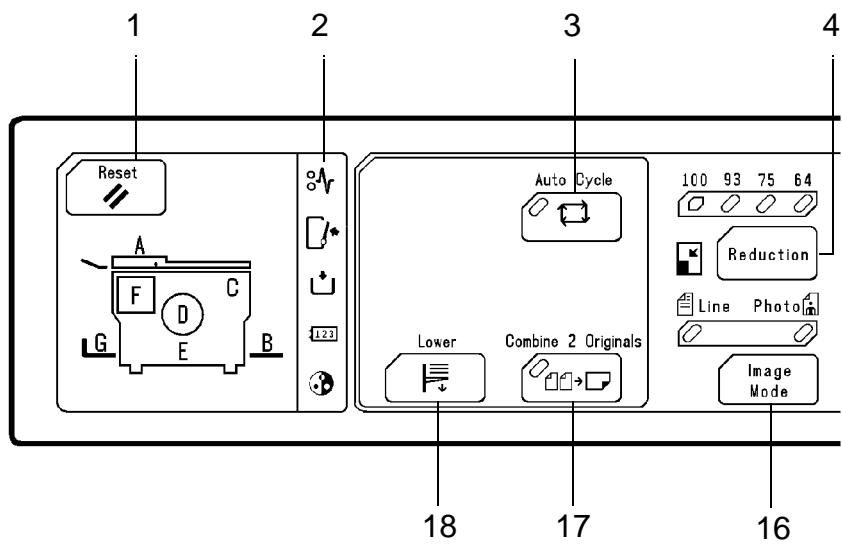

- 1. Reset Key** Press to reset error indicators.
- 2. Indicators** Light or blink when a non-standard condition occurs within the machine.
- 3. Auto Cycle Key** Use to automatically process masters and make prints.
- 4. Reduction Key** Press to reduce the image.
- 5. Image Position Keys** Press to shift the image forwards or backwards on the print paper.
- 6. Number Keys** Press to enter the number of prints.
- 7. Counter** Displays the number of prints entered. While printing, it shows the number of uncompleted prints.
- 8. Memory Display** Displays the number of the memory location that will be used to store the number of copies. The print number for up to 10 jobs can be stored at once.
- 9. Print Start Key** Press to start printing.
- 10. Master Making Key** Press to make a master.
- 11. Proof Key** Press to make trial prints or extra prints.
- 12. Stop Key** Press to stop the machine operation. The machine will continue operation when the Print Start key or Master Making key is pressed.

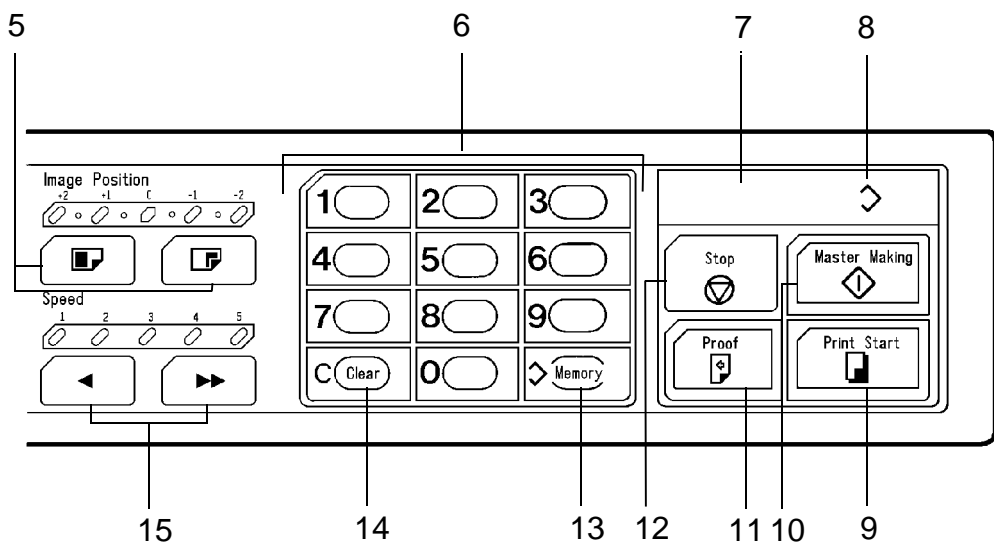

**13. Memory Key**

Use to select memory location number.

**14. Clear Key**

Press to change the number set in the counter. This key can be used only after the machine stops operation.

**15. Speed Keys**

Press to adjust the rotation speed of the machine according to the type of image and printing paper.

**16. Image Mode Key**

Press to select line mode or photo mode according to the type and quality of the original.

**17. Combine 2****Originals Key**

Press to combine two originals onto one print image.

**18. Lower Paper Feed Table Key**

Press to lower the paper feed table.

## 4. PRINTING PROCESS

---

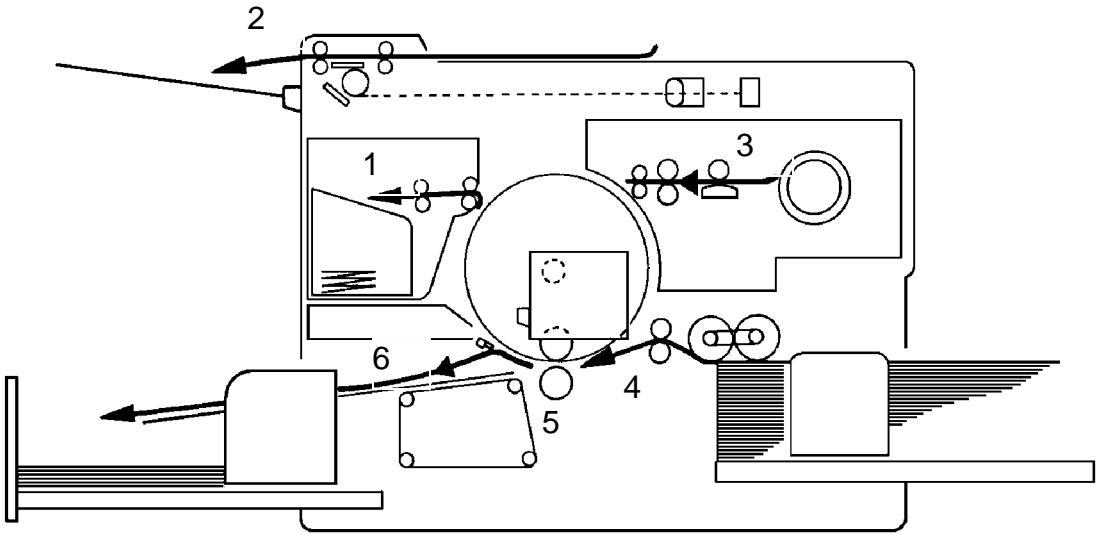

1. Master Ejecting: Eject the used master wrapped around the drum into the master eject box.
2. Scanning: Scan the original image by CCD through the mirror and the lens while feeding the original.
3. Master Feeding: Convert the image signal read by CCD into the digital signal and send it to the thermal head to make holes on the surface of the master and then, set the master around the drum.
4. Paper Feeding: Send paper to the drum section by using center separation system consisting of the separation plate and separation roller.
5. Printing: Press the paper fed from the paper feed section to the drum to transfer the ink through drum screen and the master.
6. Paper Delivering: Peel the printed paper with the Exit Pawl and Air knife and eject the paper onto the paper delivery table.



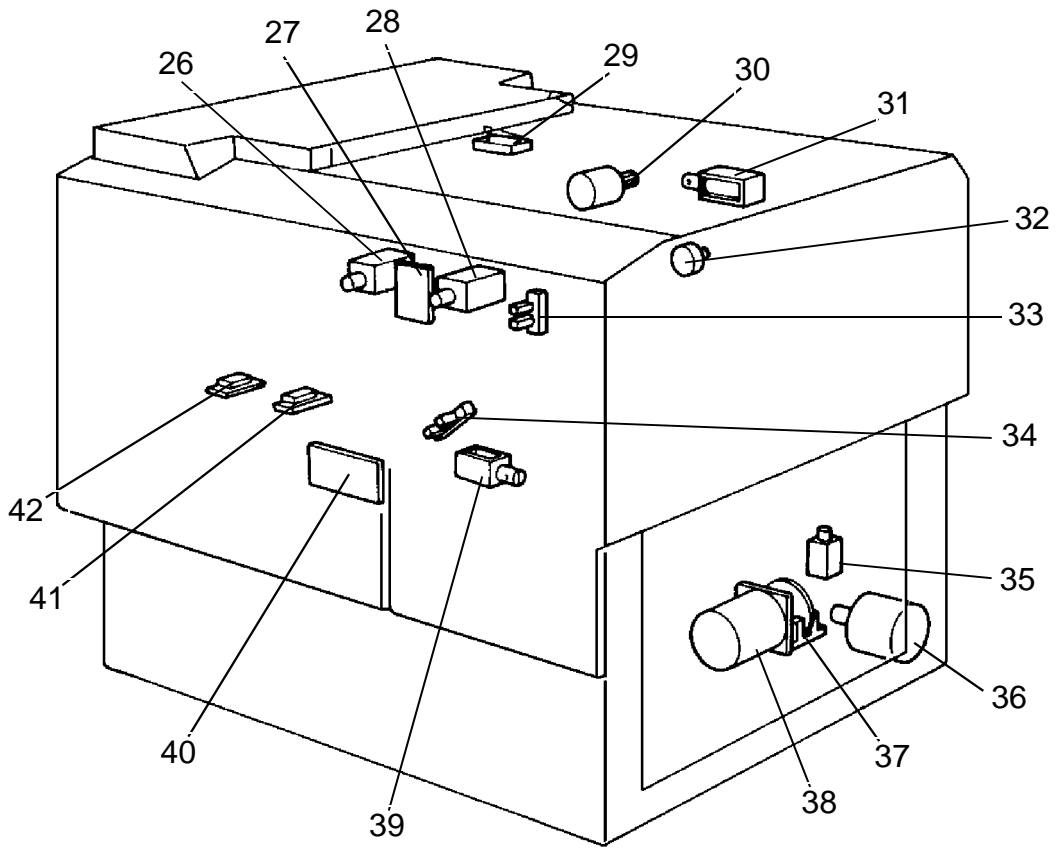

- |                                     |                                |
|-------------------------------------|--------------------------------|
| 26. Master Eject Clamper Solenoid   | 35. Paper Feed Solenoid        |
| 27. Ink Detection PCB               | 36. Paper Table Drive Motor    |
| 28. Master Feed Clamper Solenoid    | 37. Drum Rotation Sensor       |
| 29. Master Eject Unit Safety Switch | 38. Main Motor                 |
| 30. Image Shift Motor               | 39. Printing Pressure Solenoid |
| 31. Reverse Roller Solenoid         | 40. AC Drive PCB               |
| 32. Encoder                         | 41. 1st Paper Exit Sensor      |
| 33. 1st Drum Position Sensor        | 42. 2nd Paper Exit Sensor      |
| 34. 2nd Drum Position Sensor        |                                |

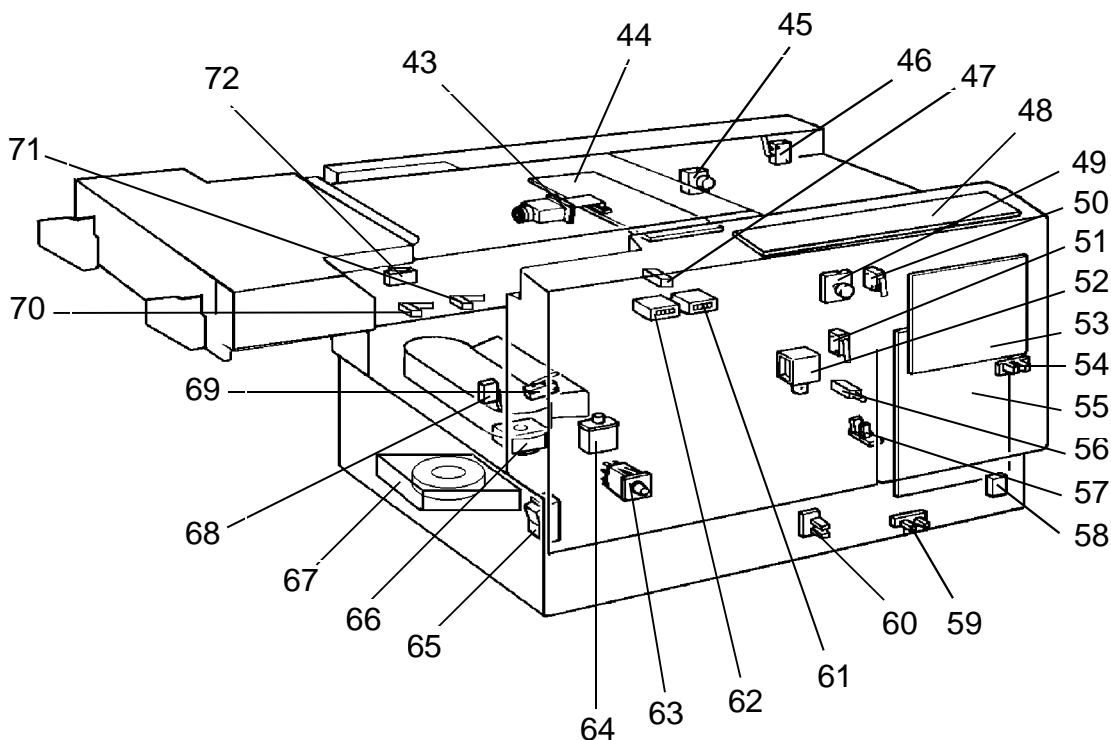

- |   |  |
|---|--|
| 43. CCD PCB   | 61. Copy Counter                                   |
| 44. A/D Conversion PCB                              | 62. Master Counter                                 |
| 45. Master Cutter Switch                            | 63. Interlock Switch                               |
| 46. Scanner Safety Switch                           | 64. Circuit Breaker                                |
| 47. Drum Master Detection Sensor<br>(VT2300/VT2500) | 65. Main Switch                                    |
| 48. Operation Panel                                 | 66. Air Knife Motor                                |
| 49. Drum Rotation Switch                            | 67. Vacuum Motor                                   |
| 50. Front Door Safety Switch                        | 68. Full Master Detecting Switch                   |
| 51. Drum Safety Switch                              | 69. Pressure Plate Position Switch                 |
| 52. Ink Supply Solenoid                             | 70. Memory/Class Switch<br>(VT2300/VT2500)         |
| 53. Main Control Board                              | 71. Skip Paper Feed Switch<br>(VT2300/VT2500)      |
| 54. Paper Table Height Sensor                       | Printing Density Switch<br>(VT2100 /VT2130/VT2150) |
| 55. Image Processing PCB                            | 72. A.D.F. Safety Switch<br>(VT2300/VT2500)        |
| 56. Drum Lock Solenoid                              |  |
| 57. Paper End Sensor                                |  |
| 58. Paper Table Safety Switch                       |  |
| 59. Paper Table Lower Limit Sensor                  |  |
| 60. Printing Pressure Sensor                        |  |

## 6. ELECTRICAL COMPONENT DESCRIPTIONS

INDEX No.	NAME	FUNCTION	P to P LOCATION
<b>Motors</b>			
4	Original Transport Motor	Transports the original to the scanner section.	A-4
11	Master Feed Motor	Feeds the master to the drum.	E-3
16	Cutter Motor	Cut the master.	F-6
19	Master Eject Motor	Sends used master into the master eject box.	F-7
23	ADF Drive Motor	Feeds the original to the scanner section.	A-4 (VT2300/2500 only)
30	Image shift Motor	Changes the timing between the paper feed roller and the drum to adjust vertical image position.	F-8
36	Paper Table Drive Motor	Raises and lowers the paper table.	F-5
38	Main Motor	Drives paper feed, drum, printing and paper delivery unit components.	F-4
66	Air Knife Motor	Rotates the fan to separate the paper leading edge from the drum.	F-7
67	Vacuum Motor	Provides suction so paper is held firmly on the transport belt.	F-5
<b>Solenoids</b>			
3	Original Pressure Solenoid	Presses the original pressure plate down on the originals.	A-4 (VT2300/2500 only)
20	Master Eject Solenoid	Moves the master eject roller to contact the drum surface.	F-6
26	Master Eject Clamper Solenoid	Opens the master clamp to eject the master.	F-8
28	Master Feed Clamper Solenoid	Opens the master clamp to clamp the master.	F-8
31	Reverse Roller Solenoid	Releases the clutch to rotate the reverse roller.	F-6
35	Paper Feed Solenoid	Releases the paper feed sector gear to rotate the paper feed roller.	F-8
39	Printing Pressure Solenoid	Moves the press roller against the drum.	F-8
52	Ink Supply Solenoid	Releases the spring clutch to activate the ink supply pump.	F-7
56	Drum Lock Solenoid	Prevents removal of the drum unit unless the drum is at the original stop position (This solenoid can be used on the VT2300/VT2500).	F-7

INDEX No.	NAME	FUNCTION	P to P LOCATION
<b>Switches</b>			
6	Right Cutter Switch	Detects when the cutter position is far right.	F-6
17	Left Cutter Switch	Detects when the cutter position is far left.	F-6
21	Master Box Switch	Checks whether the master eject box is installed correctly or not.	F-7 (VT2300/2500) F-6 (VT2100/2130 /2150)
29	Master Eject Unit Safety Switch	Checks whether the Master Eject Unit is closed correctly or not.	F-4
45	Master Cut Switch	Informs the CPU to cut the master paper leading edge.	F-8 (VT2300/2500) F-7 (VT2100/2130 /2150)
46	Scanner Safety Switch	Checks whether the scanner unit is closed correctly or not.	F-4
49	Drum Rotation Switch	Informs the CPU to rotate the main motor at 10 rpm.	A-6
50	Front Door Safety Switch	Checks whether the Front Door is set correctly or not.	F-4
51	Drum Safety Switch	Checks whether the drum unit is set correctly or not.	B-6
58	Paper Table Safety Switch	Checks whether the paper table is opened correctly or not.	F-4
63	Interlock Switch	Releases the cover safety functions.	F-4
65	Main Switch	Turns the power on or off.	B-1
68	Full Master Detecting Switch	Informs the CPU when the master eject box is full of masters.	F-7 (VT2300/2500) F-6 (VT2100/2130 /2150)
69	Pressure Plate Position Switch	Informs the CPU when the pressure plate has reached the home position.	F-7 (VT2300/2500) F-6 (VT2100/2130 /2150)
70	Memory/Class Switch	Selects Memory or Class mode.	C-4 (VT2300/2500 only)

INDEX No.	NAME	FUNCTION	P to P LOCATION
71	Skip Paper Feed Switch (VT2300/VT2500) Printing Density Switch (VT2100 series)	Adjusts paper feed interval to allow time for user to remove prints. Use to select the printing density according to the type and quality of the original.	C-4 (VT2300/2500) C-3 (VT2100/2130/2150)
72	ADF Safety Switch	Check whether the ADF unit is set correctly or not.	B-4 (VT2300/2500 only)
<b>Sensors</b>			
1	Original Registration Sensor	Informs the CPU when the original leading edge reaches the exposure glass.	A-3
2	2nd Original Sensor	Detects when the original is set.	A-3
10	Master End Sensor	Informs the CPU when the plotter unit runs out of master roll.	F-6
12	Paper Size Detection Sensor 3	Detects the size of the paper set on the paper table.	E-5 (VT2300/2500 only)
13	Paper Size Detection Sensor 2	Detects the size of the paper set on the paper table.	E-5 (VT2300/2500 only)
14	Paper Size Detection Sensor 1	Detects the size of the paper set on the paper table.	E-5 (VT2300/2500 only)
18	Master Buckle Sensor	Detects the master buckle existence.	F-6
22	Master Eject Sensor	Detects when the used master is sent into the master eject box.	F-7 (VT2300/2500) F-6 (VT2100/2130/2150)
24	1st Original Sensor	Detects when the original is set in the ADF mode.	A-4 (VT2300/2500 only)
33	1st Drum Position Sensor	Checks the position of the drum.	F-8
34	2nd Drum Position Sensor	Checks the position of the drum.	F-8
37	Drum Rotation Sensor	Supplies timing pulses to the main board.	F-8
41	1st Paper Exit Sensor	Misfeed detector.	A-5
42	2nd Paper Exit Sensor	Misfeed detector.	A-5
47	Drum Master Detection Sensor	Checks whether the master is on the drum.	F-6 (VT2300/2500 only)
54	Paper Table Height Sensor	Detects when the paper table reaches the paper feed position.	A-6



INDEX No.	NAME	FUNCTION	P to P LOCATION
57	Paper End Sensor	Informs the CPU when the paper table runs out of paper.	F-5 (VT2300/2500) B-6 (VT2100/2130 /2150)
59	Paper Table Lower Limit Sensor	Detects when the paper table reaches the lowest position.	A-6
69	Printing Pressure Sensor	Informs the CPU when the printing pressure is applied.	A-6
<b>Printed Circuit Board</b>			
7	Power Supply PCB	Rectifies 100V AC input and supplies DC voltage.	D-1
8	Thermal Head Drive Control PCB	Supplies the power to the Thermal Head according to the signal from the scanner section.	E-2
27	Ink Detection PCB	Control the ink supply.	F-7
40	AC Drive PCB	Controls the AC component by relays.	E-5
43	CCD PCB	Converts the light intensity into the electrical signal.	A-2
44	A/D Conversion PCB	Converts the analogue signal into the digital signal.	B-3
48	Operation Panel	Controls the LED performance and monitors the key operation.	A-8
53	Main Control PCB	Controls all machine functions both directly and through other boards.	C-6
55	Image Processing PCB	Controls the master processing performance.	C-3
<b>Printed Circuit Board</b>			
15	Paper Size Detection Board	Detects the size of the paper set on the table.	E-5 (VT2300/2500 only)
<b>Counters</b>			
61	Copy Counter	Keeps track of the total number of copies made.	A-7
62	Master Counter	Keeps track of the total number of masters made.	A-7
<b>Others</b>			
5	Fluorescent Lamp Stabilizer	Stabilizes the power supplement to the Fluorescent Lamp.	B-3
9	Thermal Head	Plots the master with heat.	F-2
25	Fluorescent Lamp	Applies light to the original for exposure.	A-3
32	Encoder	Converts 16 image positions to 4 bit data.	F-7
64	Circuit Breaker	Cuts the ac line off.	B-1

## 7. MECHANICAL COMPONENT LAYOUT

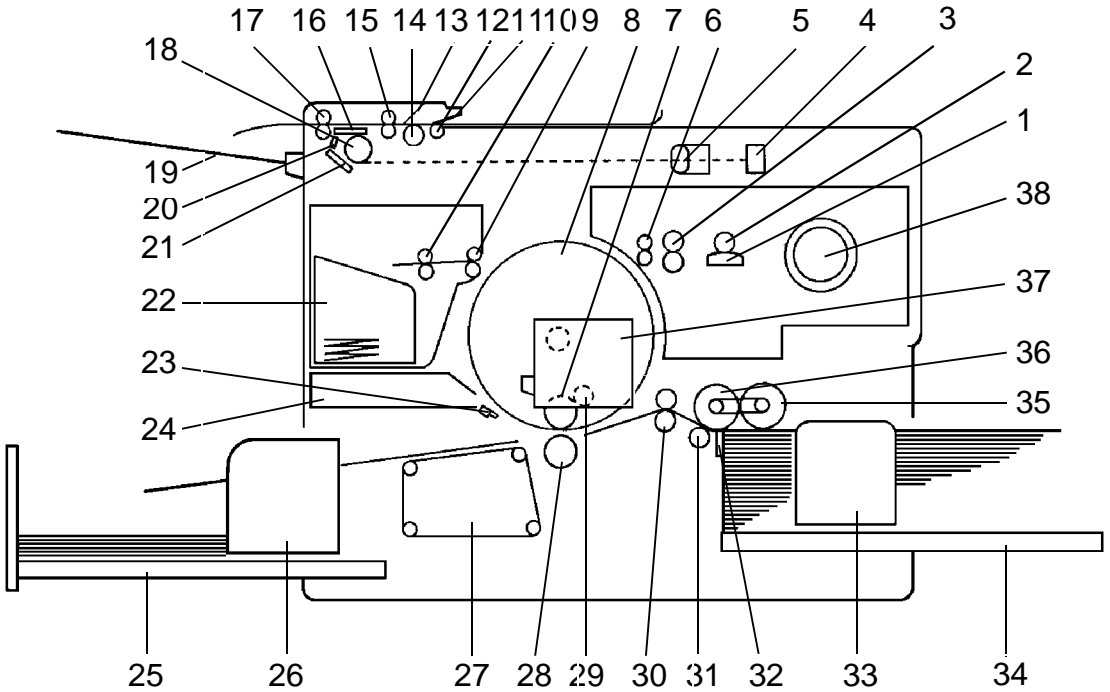

- |  |                             |
|--|-----------------------------|
| 1. Thermal Head                            | 21. Mirror                  |
| 2. Platen Roller                           | 22. Master Eject Box        |
| 3. Master Feed Roller                      | 23. Exit Pawl               |
| 4. CCD                                     | 24. Air Knife               |
| 5. Lens                                    | 25. Delivery Table          |
| 6. Reverse Roller                          | 26. Delivery Guide Plate    |
| 7. Ink Roller                              | 27. Vacuum Unit             |
| 8. Drum Unit                               | 28. Press Roller            |
| 9. 1st Eject Roller                        | 29. Doctor Roller           |
| 10. 2nd Eject Roller                       | 30. 2nd Feed Roller         |
| 11. Original Pressure Plate<br>(2300/2500) | 31. Lower Separation Roller |
| 12. Pull-out Roller (2300/2500)            | 32. Separation Plate        |
| 13. Separation Blade (2300/2500)           | 33. Paper Feed Side Plate   |
| 14. Original Feed Roller (2300/2500)       | 34. Paper Feed Table        |
| 15. 1st Original Transport Roller          | 35. Paper Feed Roller       |
| 16. Exposure Grass                         | 36. Upper Separation Roller |
| 17. 2nd Original Transport Roller          | 37. Ink Holder              |
| 18. Fluorescent Lamp                       | 38. Master Spool            |
| 19. Original Exit Tray                     |                             |
| 20. Feed Sub Mirror                        |                             |

**SECTION 2**  
**SECTIONAL DESCRIPTION**

# 1. ORIGINAL FEED SECTION

---

## 1.1 OVERALL: VT2300/VT2500

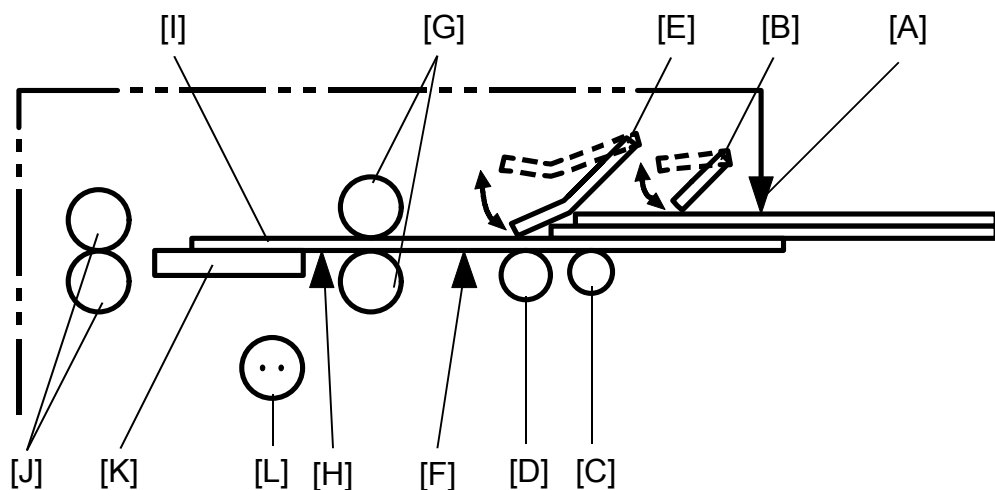

[J]: 2nd Original Transport Rollers

[K]: Exposure Glass

[L]: Fluorescent Lamp

There are two original feed modes in this model.

**ADF Mode:** The originals [I] set on the original table are detected by the 1st original sensor [A]. When the Master Making key is pressed, the original pressure plate [B] presses the originals down. The pull-out roller [C] starts moving the lowest original forward at the same time. The lowest original is separated from the other originals by the original feed roller [D] and the separation blade [E]. When the 2nd original sensor [F] detects the original, the 1st original transport rollers [G] start rotating. The rollers stop after the original activates the original registration sensor [H]. The 1st original transport rollers start rotating again after the drum section completes the preparation for the master making.

**SADF Mode:** The separation blade [E] is released in the SADF mode. The original on the original table is fed to the starting position when the 2nd original sensor [F] detects the original.

## 1.2 OVERALL: VT2100/VT2130/VT2150

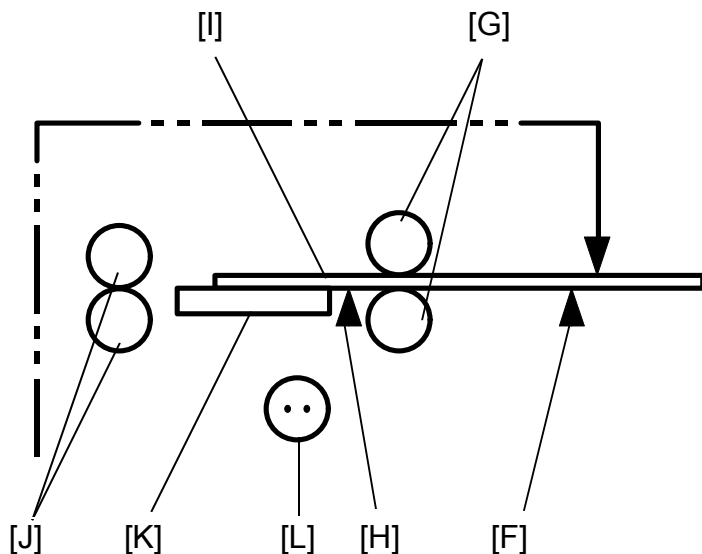

[J]: 2nd Original Transport Rollers

[K]: Exposure Glass

[L]: Fluorescent Lamp

[H]: Original Registration Sensor

The original [I] set on the original table is detected by the 2nd original sensor [F]. At the same time, the 1st original transport rollers [G] and 2nd original transport rollers [J] start rotating and feed the original to the original start position where is 12 mm far from the guide plate. The original transport rollers start rotating again after the drum section completes the preparation for the master making.

### 1.3 ORIGINAL FEED DRIVE MECHANISM: VT2300/VT2500

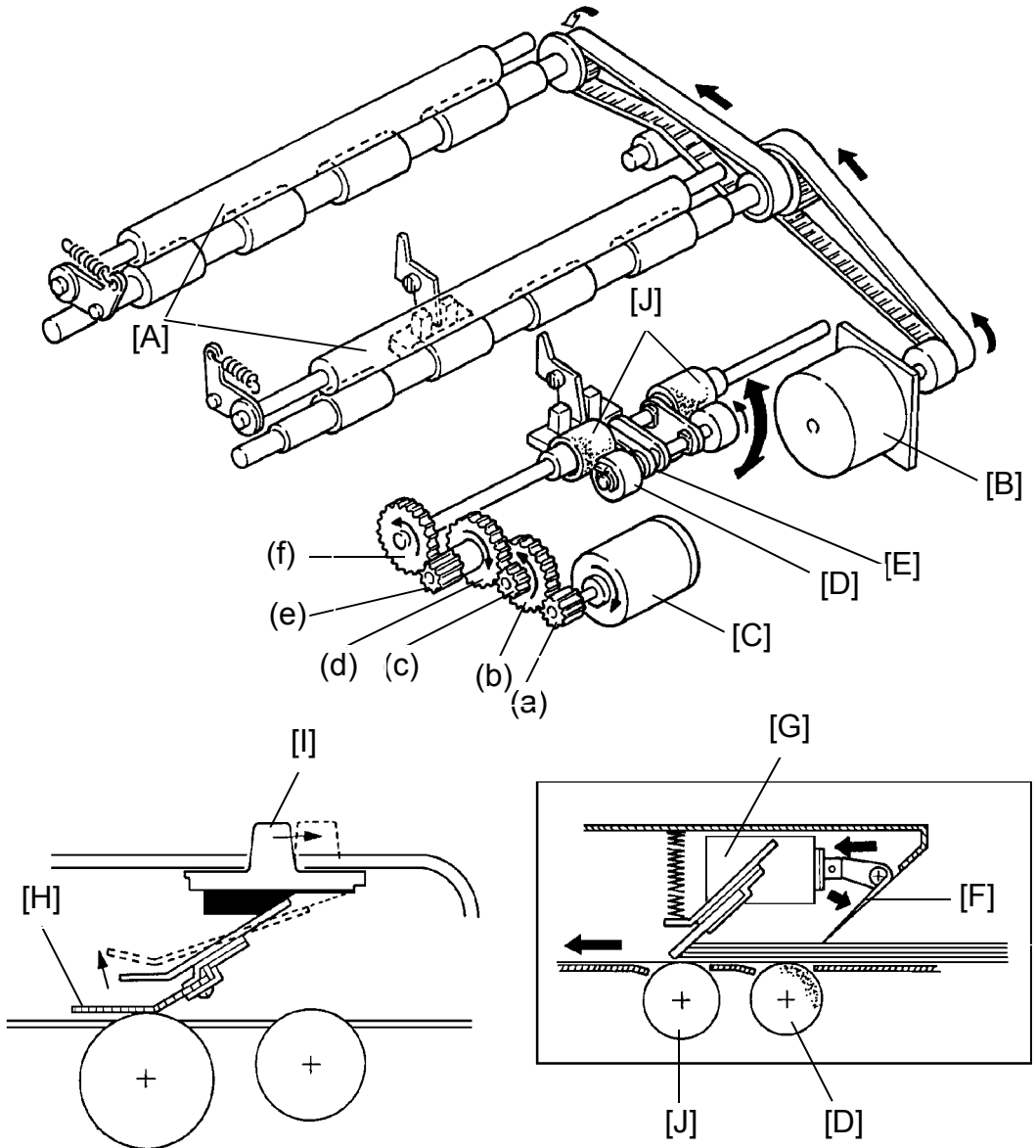

The original transport rollers [A] are driven by the original transport motor [B], which is a stepper motor. The original feed rollers [J] are driven by the ADF drive motor [C] through a series of gears [(a) to (f)]. The ADF drive motor is a dc motor. The pull-out rollers [D] are driven by the ADF motor through a drive belt [E].

The original pressure plate [F] is pressed down on the originals by the original pressure solenoid [G]. The separation blade [H] is moved up and down by the ADF ON/OFF select switch [I].

## 1.4 ORIGINAL FEED DRIVE MECHANISM: VT2100/VT2130 /VT2150

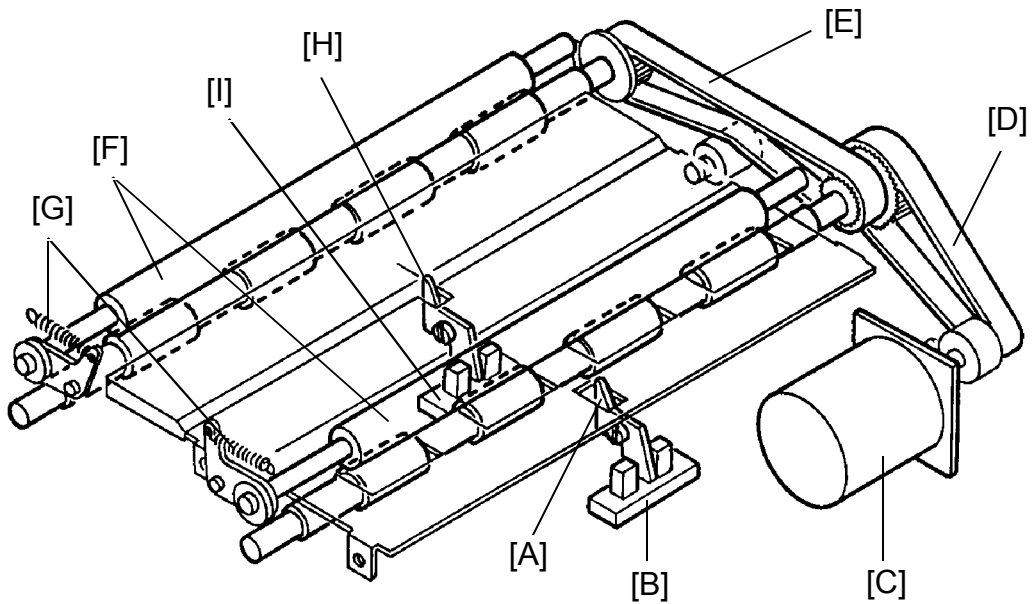

When the actuator [A] is pressed down by the original, the 2nd original sensor [B] is activated and the original transport motor [C] starts rotating. The rotation of the original transport motor is transmitted to belts [D] and [E] to turn the lower first original transport roller and lower second original transport roller. At the same time, both the upper original transport rollers [F] contact the first and second lower original transport rollers due to pressure from the springs [G]. The rollers rotate and the original is fed.

When the actuator [H] is pressed down by the original, the original registration sensor [I] is activated and the original transport motor stops.

When the Master Making key is pressed, the original transport motor rotates to read the original after the master eject process is finished.

The distance between the sensors is 50 millimeters. If the original registration sensor is not activated within five seconds, "A" and  indications blink.

## 1.5 ELECTRICAL TIMING: VT2300/VT2500

(One Original):

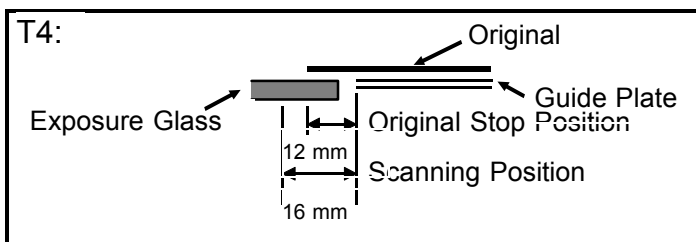
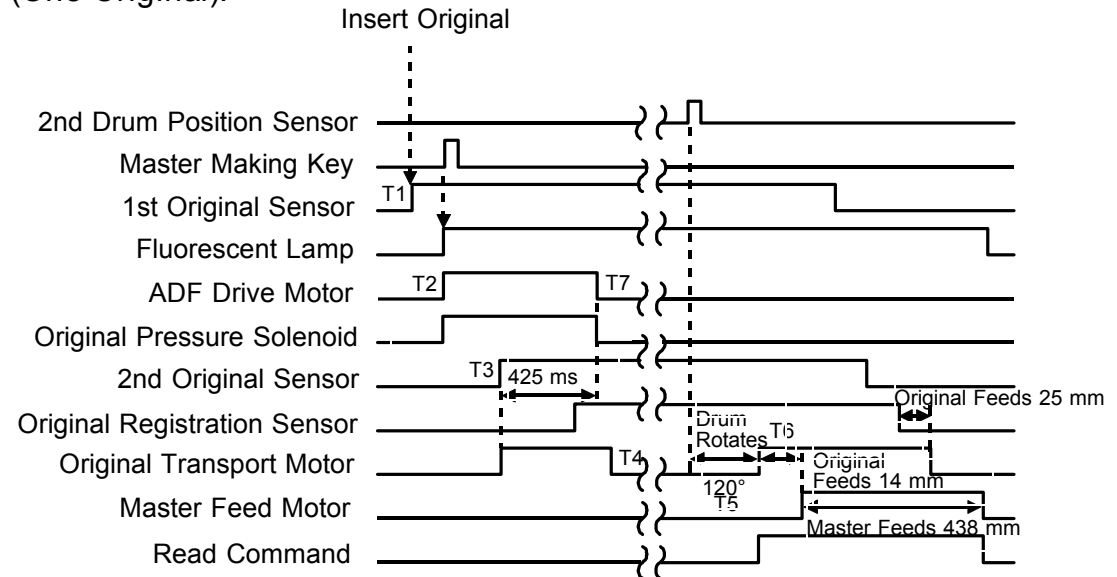

- T1: When originals are inserted in the ADF unit, the 1st original sensor is activated.
- T2: When the Master Making key is pressed, the ADF drive motor starts rotating and the pull-out roller and original feed roller feed the 1st original. At the same time, the original pressure solenoid is energized and the pressure plate presses the originals against the pull-out rollers.
- T3: When the 2nd original sensor detects the original, which is separated by the separation blade and the original feed roller, the original transport motor starts rotating and the transport rollers start rotating.
- T4: One original is fed and when the original registration sensor detects the original, the original transport motor stops the original position is then as shown above.
- T5: After the master eject process is finished and the second drum position sensor is activated, the drum rotates 120 degrees more and then the original transport motor turns on.



- T6: After the original is fed 14 millimeters, master feeding and master making start.
- T7: The ADF drive motor and the original pressure solenoid are turned off 425 mseconds after the 2nd original sensor detects the original.
- If 2nd original sensor is not activated within 2.3 seconds after pressing the Master Making key, the Original Misfeed indicator (A + 8) will start blinking.

(Make-up mode): VT2500 only

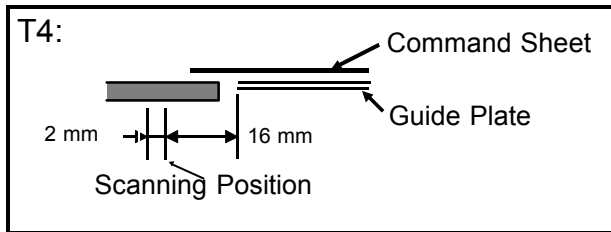
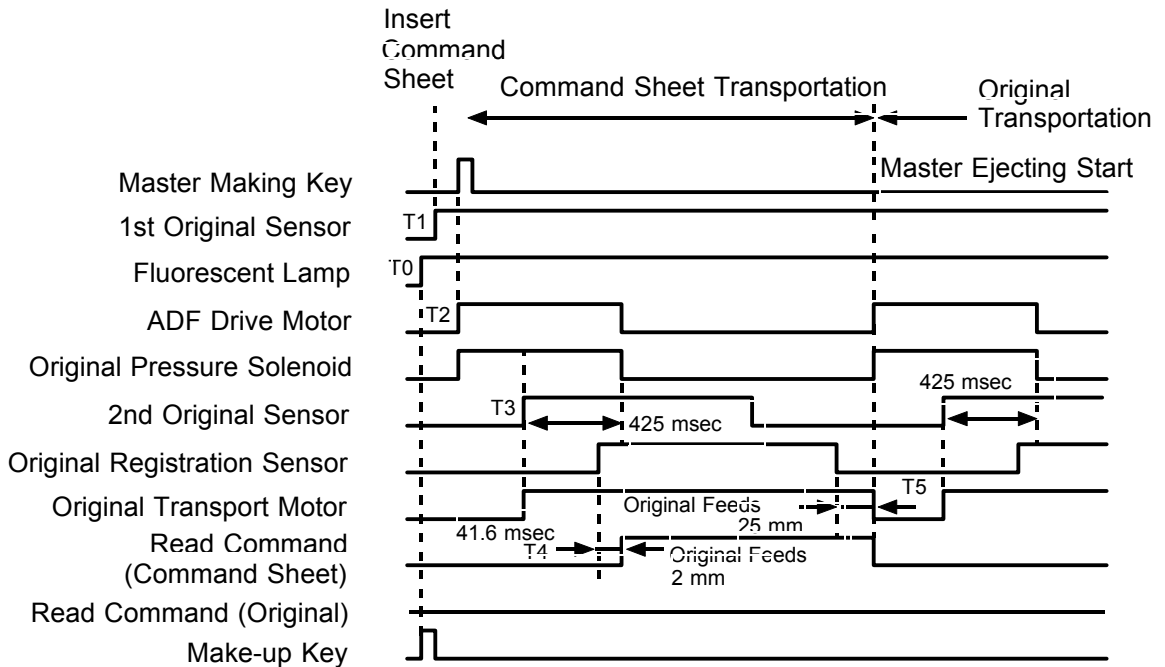

- T0: When the Make-up key is pressed, the fluorescent lamp turns on.
- T1: When the original is inserted with a command sheet, the 1st original sensor is activated.
- T2: When the Master Making key is pressed, the ADF drive motor turns on and the command sheet is fed by the pull-out rollers and the original transport rollers. At the same time, the original pressure solenoid is energized and the original pressure plate presses down on the original and the command sheets.
- T3: The original transport motor starts rotating when the 2nd original sensor is activated by the command sheet.
- T4: The reading command is output when the command sheet is fed 2mm past the scanning position.
- T5: The original transport motor stops rotating when the command sheet is fed 25 mm past the original registration sensor. At the same time, the reading command turns off. The ADF drive motor and the original pressure solenoid turn on at the same time and the original is fed.

## 1.6 ELECTRICAL TIMING: VT2100/VT2130/VT2150

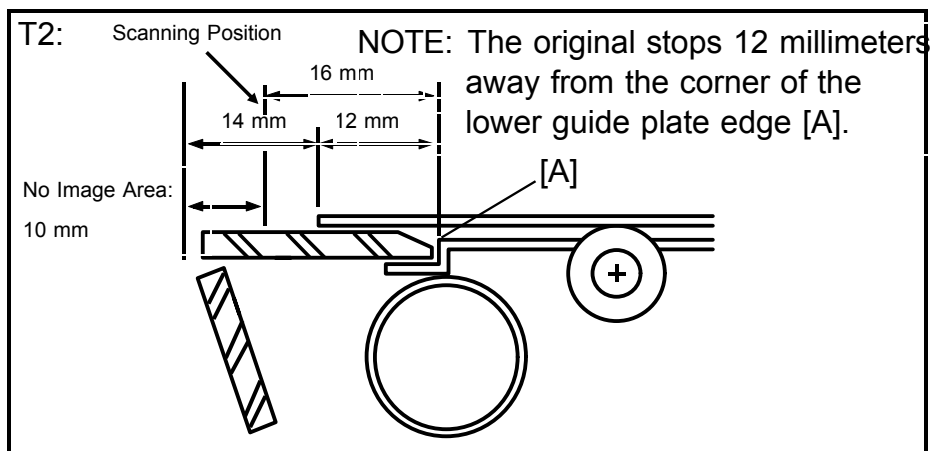
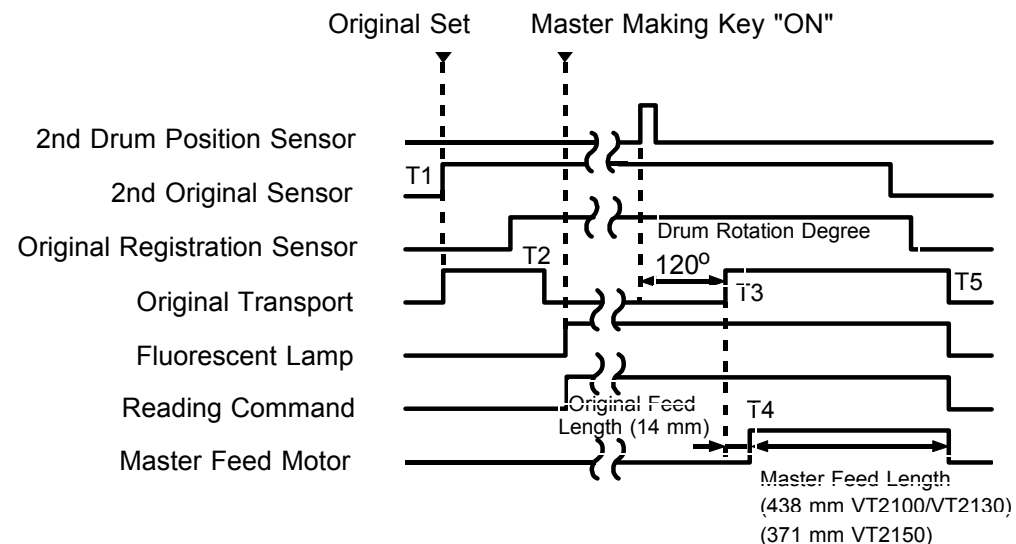

- T1: When the 2nd original sensor detects the original, the original transport motor starts rotating.
- T2: One original is fed and when the original registration sensor detects the original, the original transport motor stops the original position is then as shown above.
- T3: After the master eject process is finished and the second drum position sensor is activated, the drum rotates 120 degrees more and then the original transport motor turns on.
- T4: After the original is fed 14 millimeters, master feeding and master making start.
- T5: The master feed motor stays on until it feeds the master 437 mm. The original transport motor stops when the master feeding stops. At that time the fluorescent lamp also turns off.

1.7 CIRCUIT:

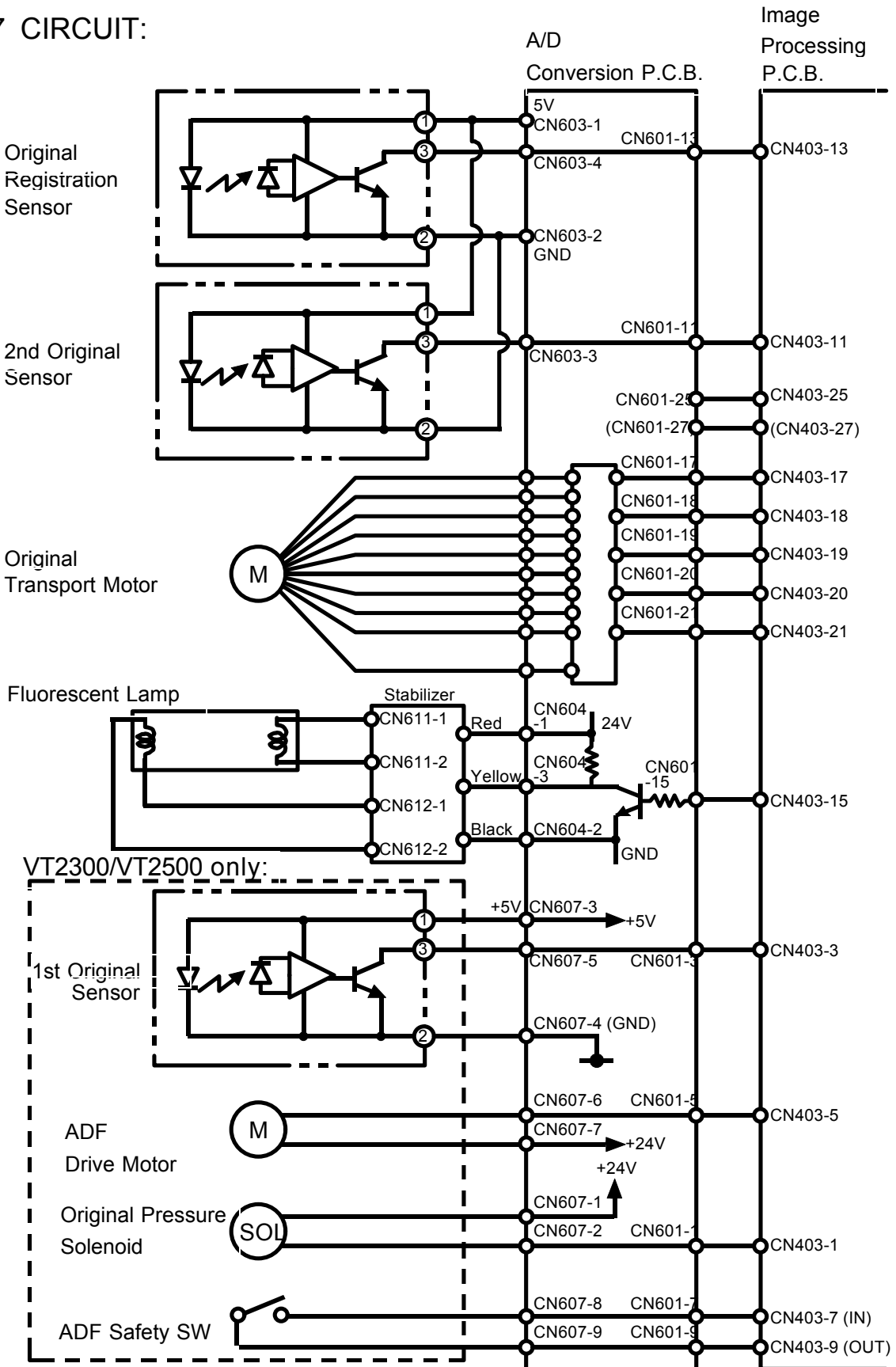

## 1.8 OUTPUTS:

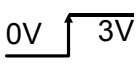
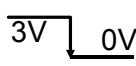
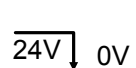
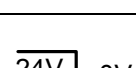
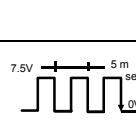
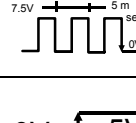
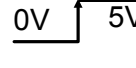
Signal Name	I/O	A/D Conversion Board		Description
		CN No.	Level	
Fluorescent Lamp	O	CN601-15		When the fluorescent lamp turns on, the voltage of the CN601-15 is 3V.
Reading Command	I	CN601-25 (CN601-27)		When the CCD reads the original the voltage of CN601-25 (CN601-27) is 0V.
ADF Drive Motor (VT2300/VT2500)	I	(CN607-6)		When the ADF drive motor starts rotating, the voltage of CN607-6 is 0V.
Original Pressure SOL (VT2300/VT2500)	O	(CN607-2)		When the original pressure solenoid is energized, the voltage of CN607-2 is 0V.
Original Registration Sensor	O	CN603-4		When the original registration sensor is activated, the voltage of CN603-4 is 0V.
2nd Original Sensor	I	CN603-3		When the 2nd original sensor is activated, the voltage of CN603-3 is 0V.
1st Original Sensor (VT2300/VT2500)	I	(CN607-5)		When the 1st original sensor is activated the voltage of CN607-5 is 5V.

( ): VT2300/VT2500

## 2. OPTICS/IMAGE PROCESSING

### 2.1 OVERALL

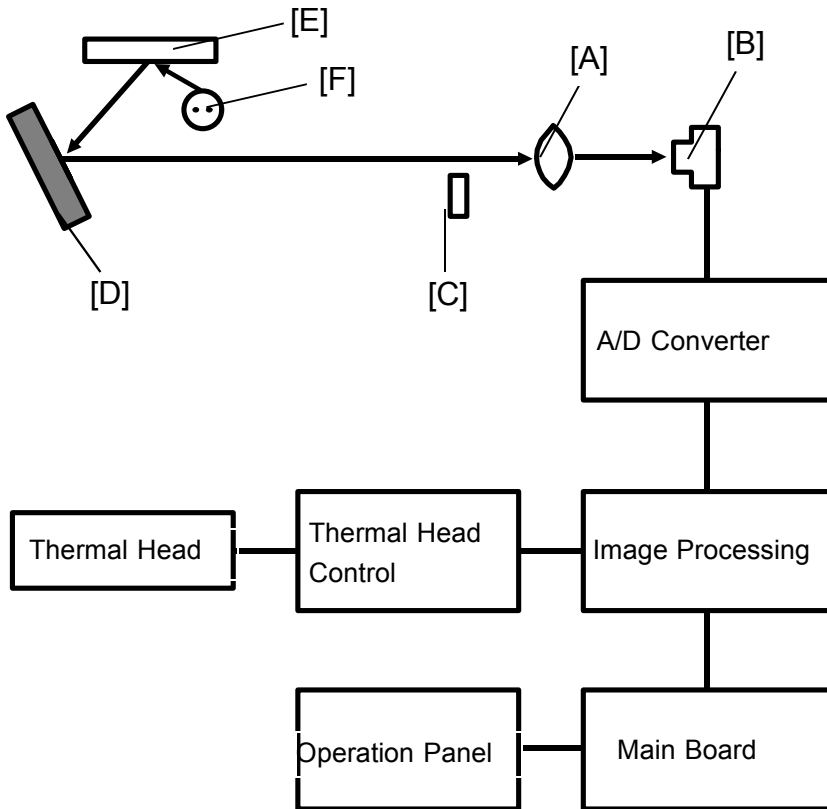

[C]: Shading Plate

[D]: Mirror

[E]: Exposure Glass

[F]: Fluorescent Lamp

The light reflected from the original goes through the lens [A] and is changed to an electrical signal in the CCD [B].

The electrical signal from the CCD is converted from an analog signal to a digital signal in the A/D converter.

The converted digital image data is modulated and edited (VT2500) and is sent to the thermal head control PCB.

## 2.2 LIGHT SOURCE

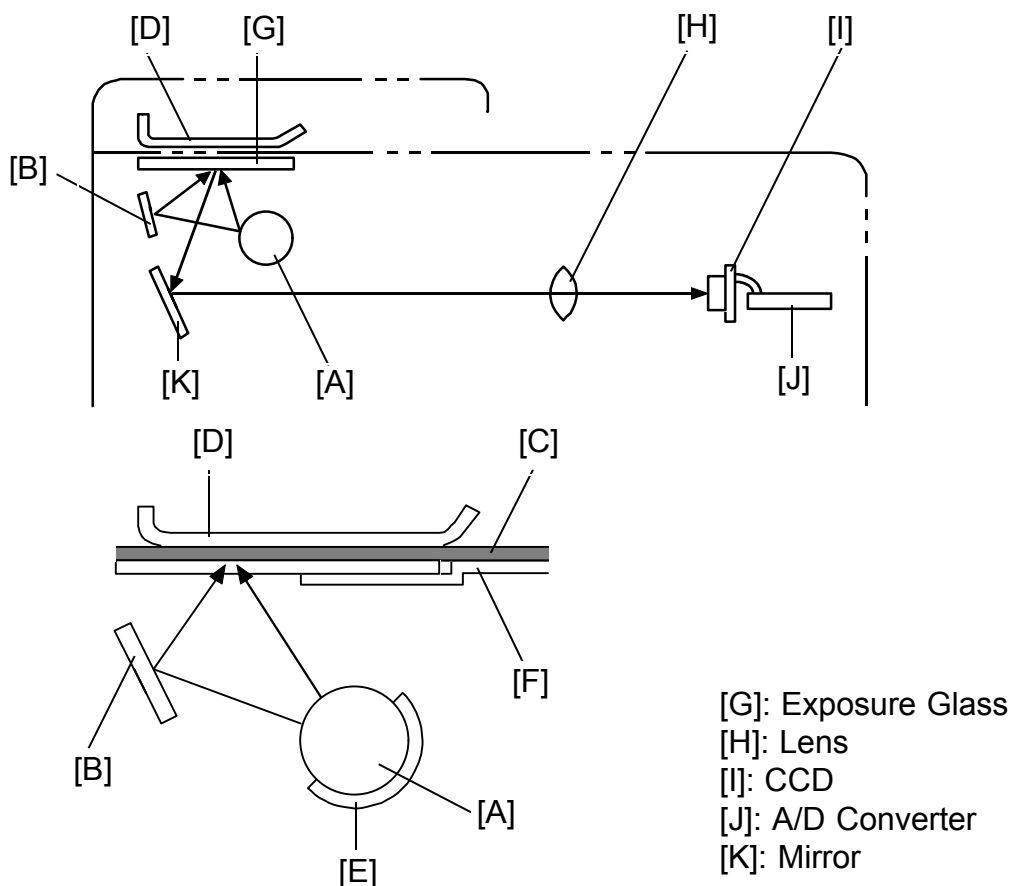

The high frequency fluorescent lamp [A] is used as a light source for the high speed reading of 16 pixels/mm. The light exposes at two angles using a sub mirror [B] to prevent the shades at the edges of paste-ups on the original [C]. The original guide plate [F] blocks part of the direct light from the fluorescent lamp to make the light intensity of both direct and reflected light the same. A heater [E] is wrapped around the fluorescent lamp. It prevents light intensity reduction due to low temperature.

### <Fluorescent Lamp>

Form: 15.5  $\varnothing$  x 436 mm  
 Lamp Voltage :  $59 \pm 6$  V

### — Platen Cover —

The platen cover [D] is used as a standard white level reference to correct for shading distortion.

## 2.3 LENS

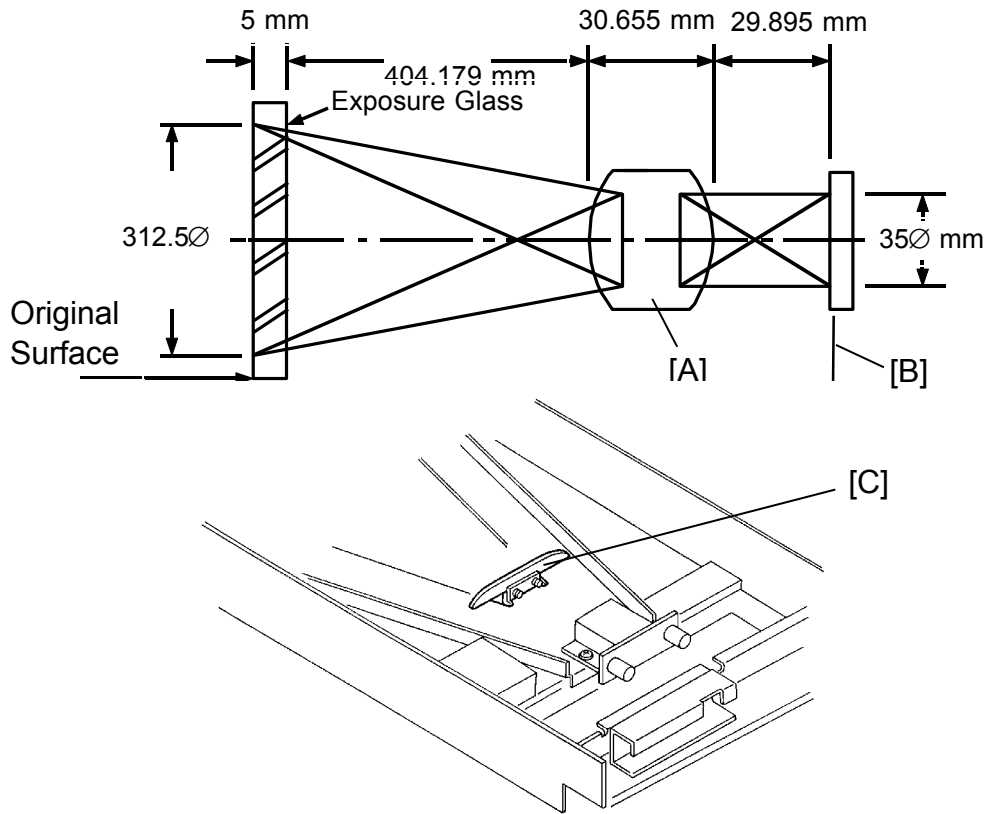

This consists of 6 lenses, to transfer the image, correctly oriented, to the photoelectric elements of the CCD. It is possible to adjust the focus by moving the lens assembly [A].

### <Lens>

Focal distance: 43 mm ( $43.05 \pm 0.32$  mm)  
 F No.: F4.5

The above illustration shows the layout to transfer the image from an A3 original (297 millimeter width) to the CCD [B].

### <CCD>

Number of effective pixels: 5000 pixels  
 Reading length: 312.5 mm  
 Photo signal storage time: 3 msec.

The shading plate [C] corrects light intensity distortion. The light intensity is low at the both ends of the lamp and is also low at the edge of the lens. Therefore, the center light is cut to make the light intensity uniform.



## 2.4 CCD (Charge Coupled Device)

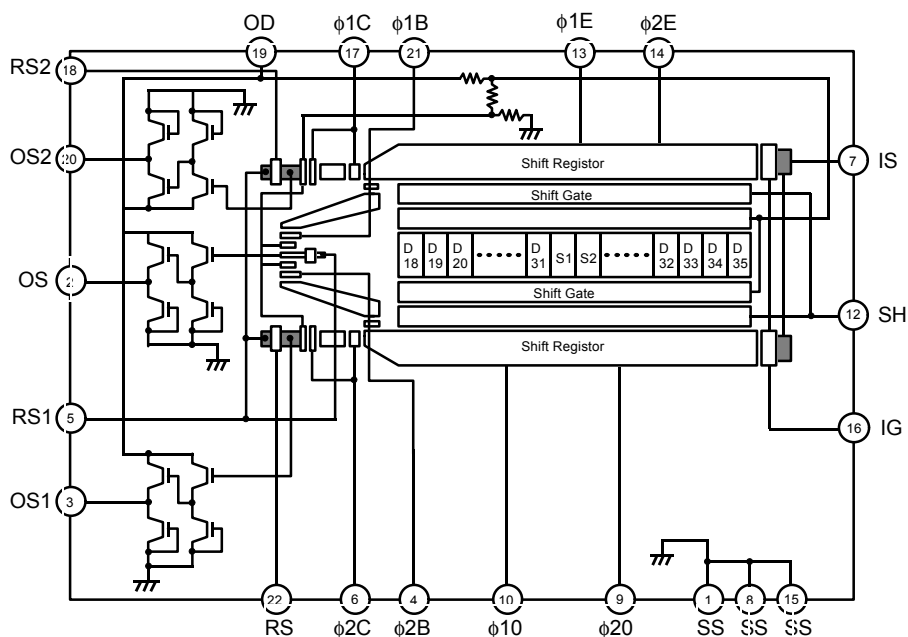

### CCD (16 dots/mm)

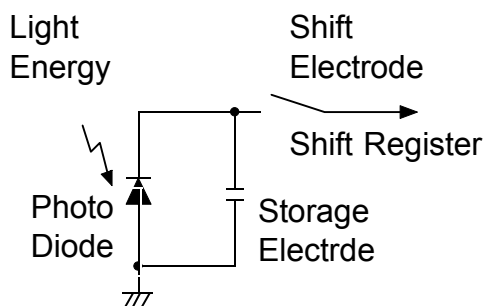

- $\phi 1E, \phi 2E$  Clock (Phase 1)
- $\phi 10, \phi 20$  Clock (Phase 2)
- 01B : Final Clock (Phase 1)
- 02B : Final Clock (Phase 2)
- SH : Shift Gate
- RS : Reset Gate
- OS : Output Transistor source
- OD : Output Transistor Drain
- SS : Sub-straight (Ground)
- IS : Input Source (Test Pin)
- IG : Input Gate (Test Pin)

This is a solid-state device similar to a photodiode array, but unlike a photodiode array, a CCD can read one complete scan line at a time. The CCD produces an analog signal which is converted into a digital signal for image processing.

## 2.4.1 Function

The principle circuit of each pixel in the CCD is shown above. The light reflected from the original is absorbed in the photodiode and the capacitor stores the charge corresponding to the light intensity.

The CCD is composed of many such pixel elements in series. The image signal of each pixel element is stored in the shift register as a charge.

When the SH signal is input, the image signal stored in the shift register, is output in serial as the OS signal.

### SH : Shift Gate

The storage electrode charge in the exposure section is transmitted to the shift register by the shift gate pulse.

### $\phi_{1E}$ , $\phi_{2E}$ Clock (Phase 1)

This is the transmission clock for analog shift register 2 (even pixels).

### $\phi_{1O}$ , $\phi_{2O}$ Clock (Phase 2)

This is the transmission clock for analog shift register 1 (odd pixels).

The shift gate signal transmits the electrical charge in parallel to either analog shift register 1 or 2 (odd or even pixels). At the same time, the photo signal storage of the next scan line starts in the exposure section.

The transmission clocks serially shift the electric charge transmitted to the shift register, which outputs it from the OS (output signal) terminal.

## 2.4.2 The Image Signal :

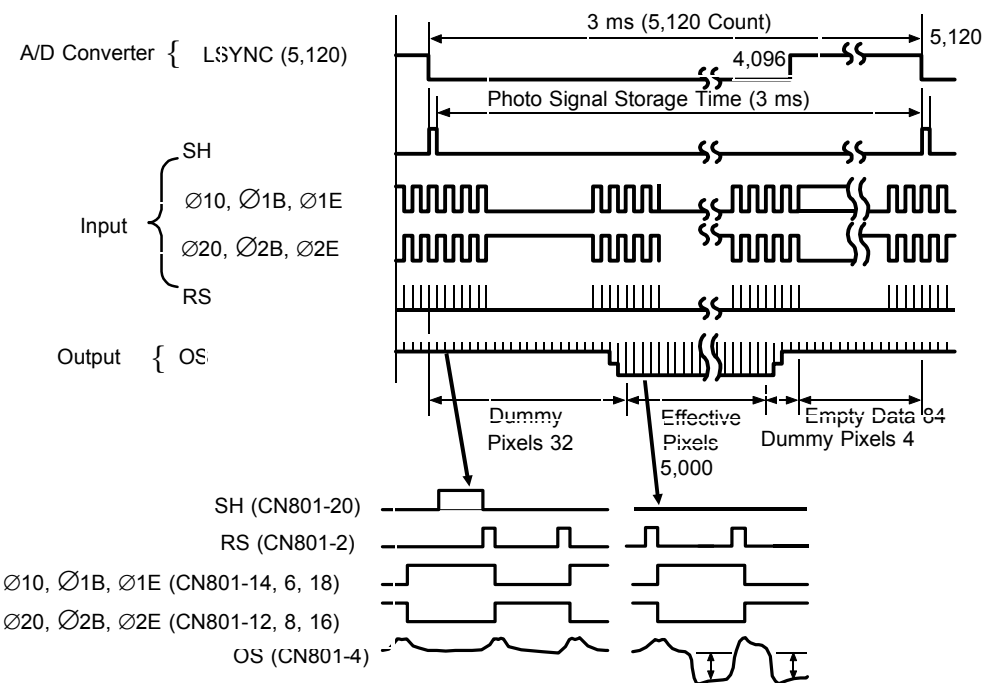
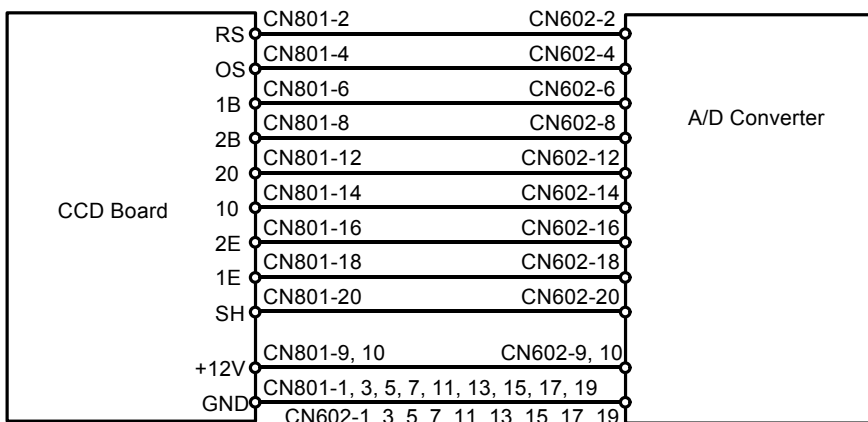

**Dummy Pixels:** The dummy pixels generated by the area covered with aluminum film. The dummy pixels are used as the standard black level.

The first 32 pixels read (D0 to D31) are dummy pixels. Pixels D32 to D5,032 are the effective pixels (S1 to S5,000). After that there are four more dummy pixels. Therefore, the total pixel count from the CCD, including the dummy pixels, is 5,036.

As the image signal captured by the CCD is clocked out by the shift gate every 3 ms (scan line period), there remains time for 84 transmission clock pulses after all the image data from the CCD has been output. These clock pulses, after all valid data have been clocked out, constitute empty data. During this period, subscanning occurs.

## 2.5 A/D CONVERSION BOARD

Outline: VT2100/VT2130/VT2150 Circuit

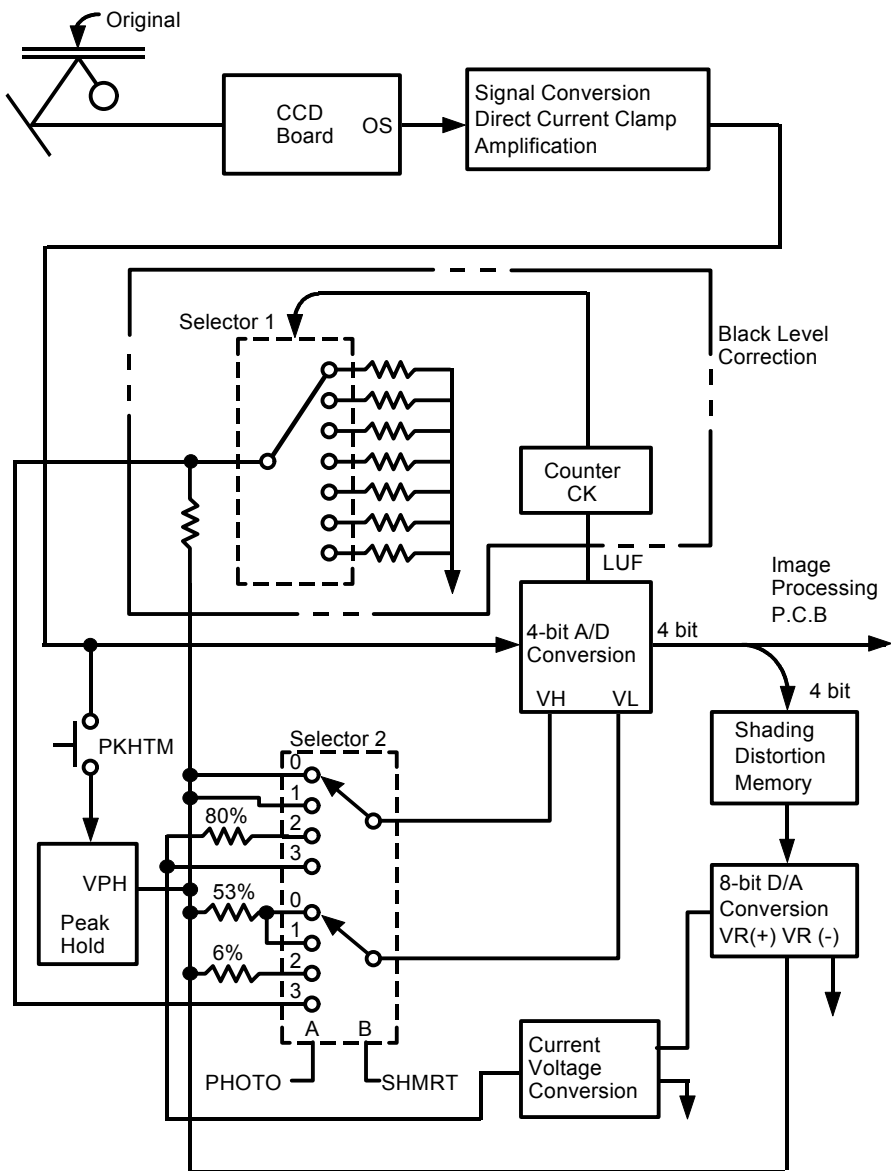

### Selector 2

- 0: Shading Distortion Correction in Photo mode
- 1: Shading Distortion Correction in Line mode
- 2: Line mode
- 3: Photo mode

The CCD reads the light of the fluorescent lamp reflected from the original. The CCD and A/D conversion boards convert the analog signals into digital signals which are transmitted to the image processing board.

## 2.5.1 CCD Output Signal Conversion, DC Clamping, Amplification:

### VT2100/VT2130/VT2150 Circuit:

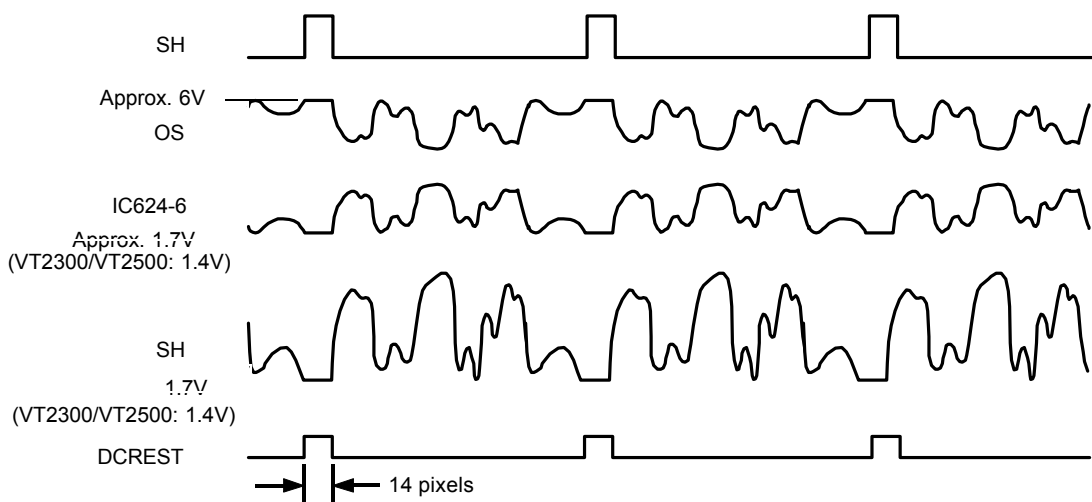
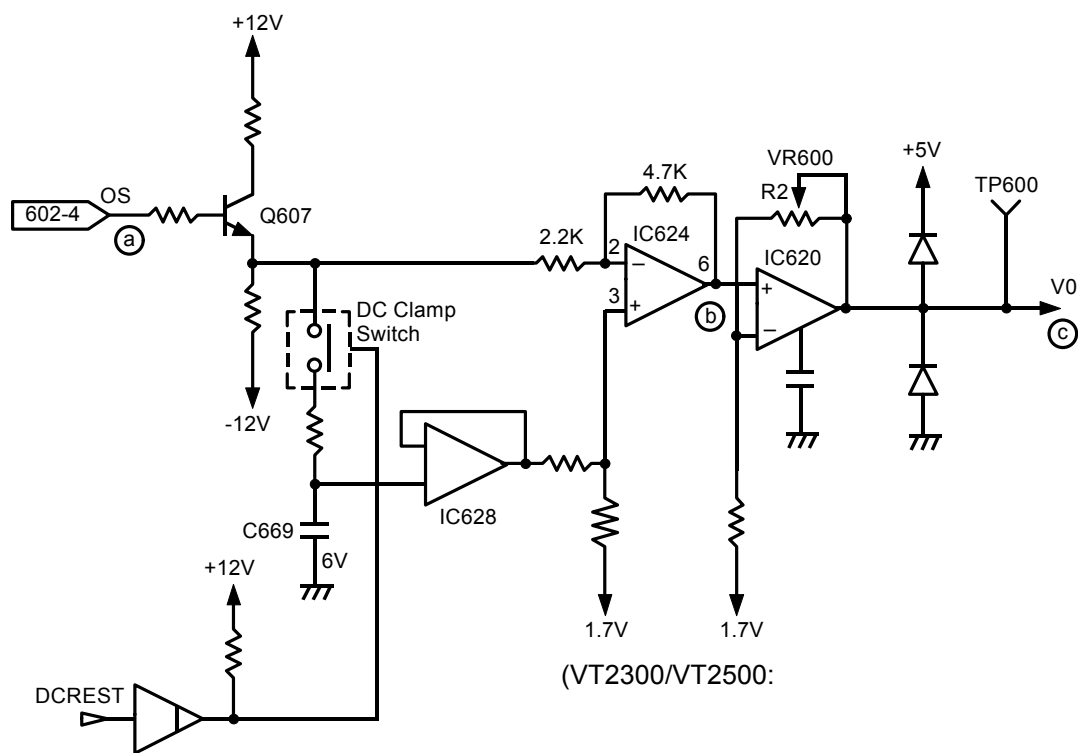

### 1). Signal Conversion

The CCD output (OS) varies according to the reflected light intensity and is clipped at 6 volts. The output signal is then buffered, inverted and amplified.

## 2). DC Clamping

The OS signal is amplified by Q607. The dc clamping switch is turned ON/OFF by the DCREST signal. The switch turns on when the CCD produces black level (empty data) at the end of scanning and is off during image scanning.

When the switch turns on, the black level signal is stored in capacitor C669. When the switch turns off, the black level signal is input to IC624 pin 3 while the image signal is input to the IC624 pin 2.

The difference between the image signal and the black level signal is amplified and output from the IC624.

This output signal from IC624 is amplified again in IC620. The signal then goes in the A/D converter.

## 2.5.2 Peak Hold:

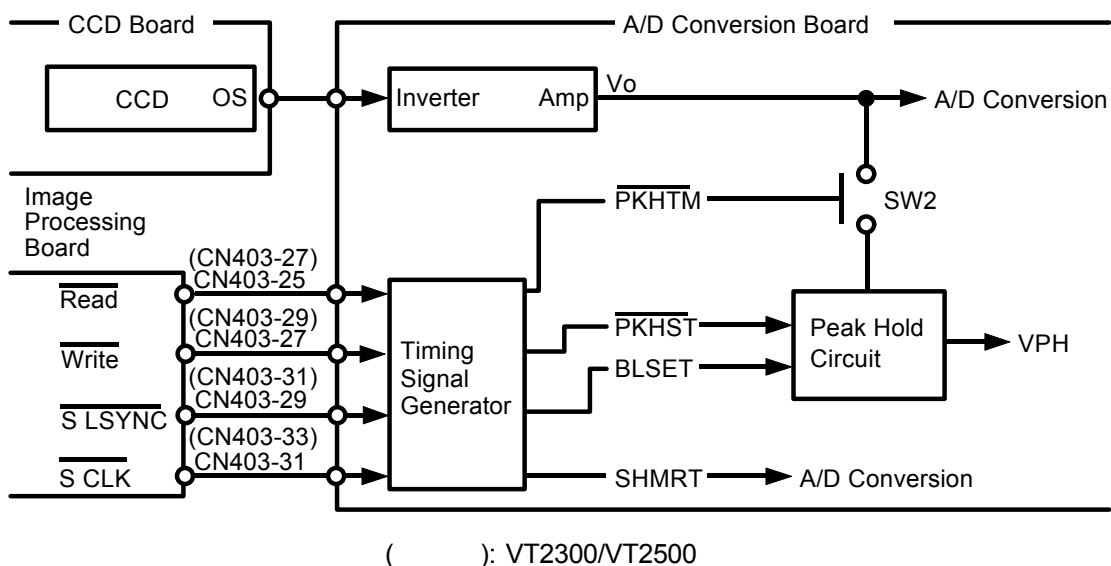

This circuit holds, at different stages of image processing, the peak white levels for both the original and the platen cover (standard white). The peak white, or maximum, level is stored as charge on a capacitor. The peak hold circuit is cleared by discharging the capacitor.

## 1). Platen Cover Peak Hold (Standard White)

The platen cover peak hold is used as standard white when processing data to create the shading distortion data, which is later stored in memory. This data is used to correct such distortions as bright or dull spots on the lamp or variations in the CCD output. To create the platen cover peak hold (standard white), the peak hold circuit stores the maximum level from five scan lines of the platen cover.

## 2). Original Background Peak Hold

The maximum white level of the original, stored in the peak hold circuit, is used to shift the threshold voltage of the D/A converter to match the original background. An area of the original, 64 mm wide (from S2,048 to S3,072), is read. This corresponds to a small size original.

## 3). Peak Hold Set Signal

The peak hold set signal (PKHST) clears the peak hold circuit. The peak hold timing signal (PKHTM) turns on the analog switch (SW2) allowing the image signal to be applied to the peak hold circuit.

#### 4) Peak Hold Signal Timing:

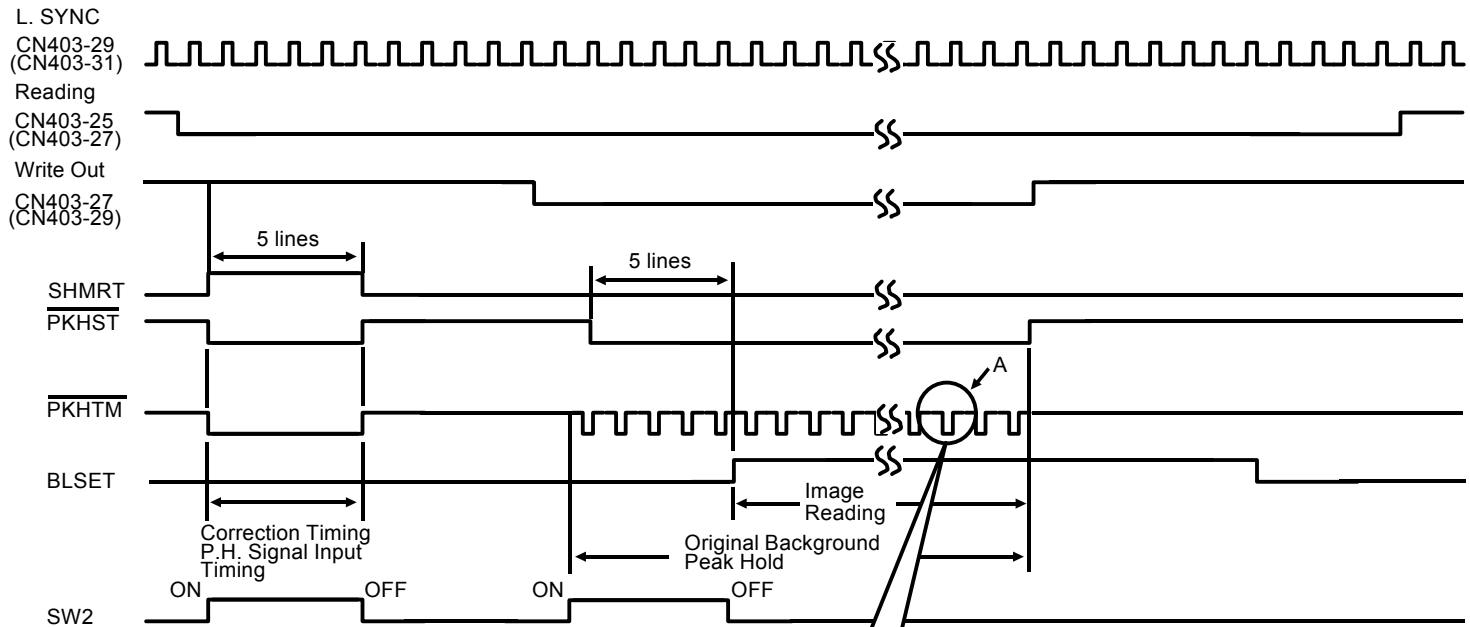

( ): VT2300/VT2500  
 A Section (Main Scanning)

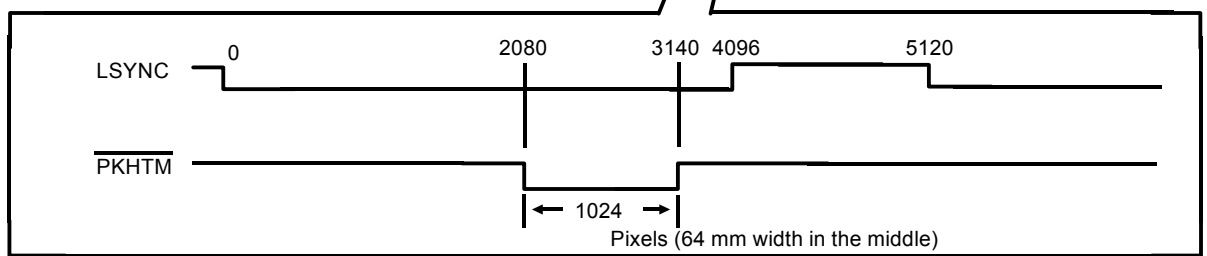



### 2.5.3 Shading Distortion Correction:

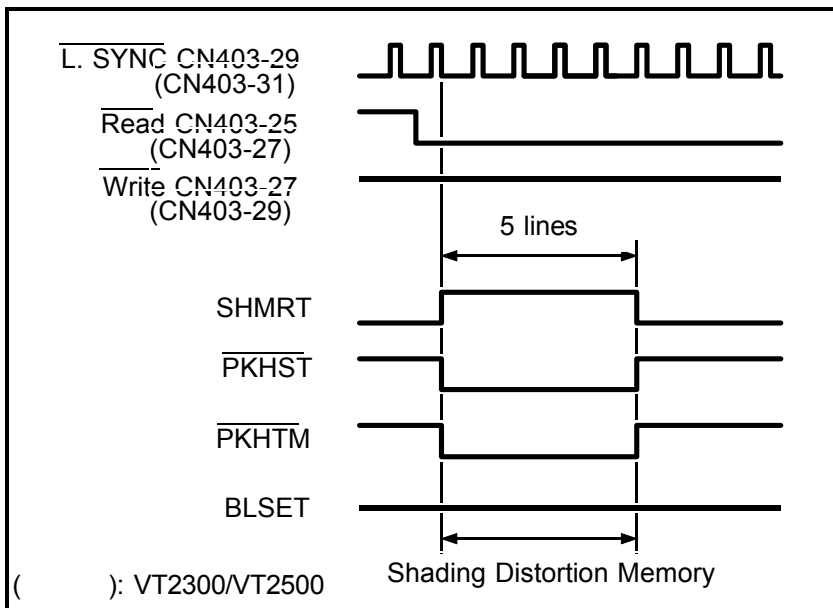
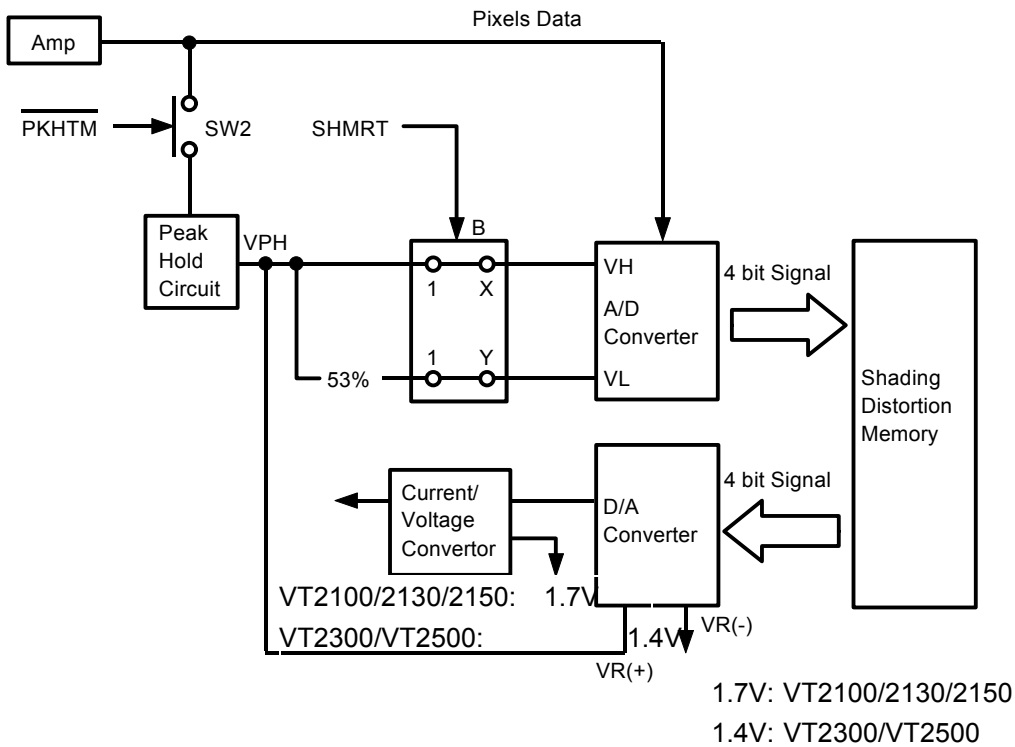

Since the output of the CCD varies according to both the CCD and the intensity of the fluorescent lamp, shading distortion is corrected electrically as well as mechanically (shading plate).

## 1). Shading Distortion Memory

### White Peak Hold of Platen Cover

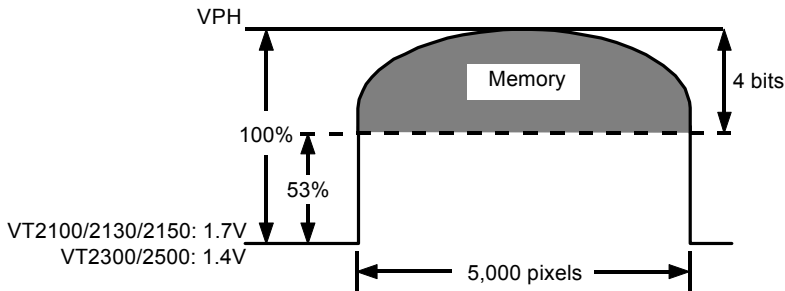

When reading the white level of the platen cover, the peak hold (standard white) is determined using the five scan lines.

The shading distortion data is stored in memory during the fifth scan line .

The potential difference between the output of each pixel and the 53% level of the peak hold is converted by an A/D converter into 4-bit data. This data is stored in a memory location corresponding to the pixel.

## 2). Shading Distortion Correction

### White Peak Hold of Original Background

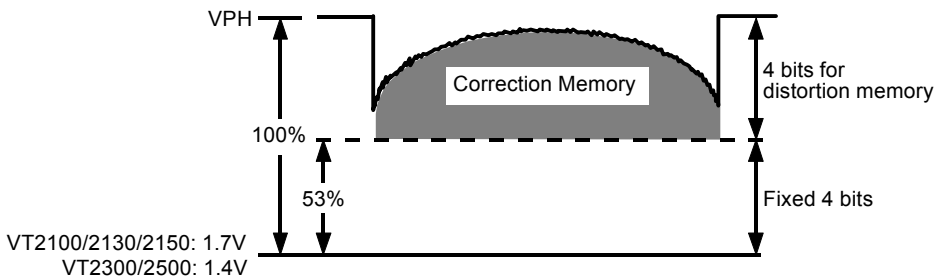

When reading the original, the distortion data corresponding (stored in memory) to each pixel is converted from digital to analog, using the D/A converter, and used as the reference voltage ( $V_H$ ) of the A/D converter.

The D/A converter is an 8-bit converter with 4 of its 8 bits fixed. This ensures that the output of the D/A converter is always greater than 53% of the reference voltage ( $V_{R+}$ ).

The reference ( $V_{R+}$ ) of the D/A converter is set to the peak hold of the original background. Distortion correction is obtained by using the output voltage of the D/A converter as the reference voltage ( $V_H$ ) of the A/D converter; therefore, distortion correction also corrects for the original background level.

For Example: If the light intensity at a certain pixel is very high, then a high voltage level will be stored in the distortion memory location for that pixel. When reading a document, that high voltage level is used as the reference level ( $V_H$ ) of the A/D converter. Therefore, during conversion, the input level from the pixel is compared to a high voltage by the A/D. This negates any errors caused by the high light intensity at that pixel.

## 2.5.4 Original Background Correction

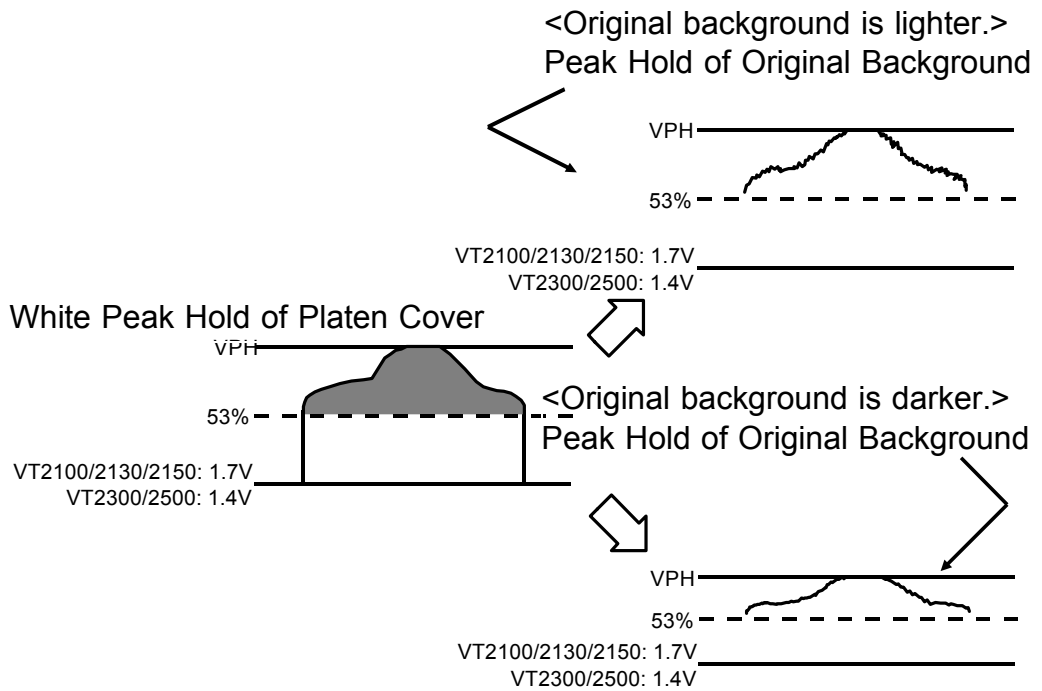

As the white peak hold of the original background is used as the reference ( $V_{R+}$ ) of the D/A converter, the overall shading distortion correction level is adjusted for the original background at the output of the D/A converter.

For Example, if the background level of the original is low, the reference level ( $V_H$ ) of the D/A converter is low, causing the overall distortion correction level to be low. Therefore, even though the light level from the original background is low, it is being compared to a low reference level ( $V_H$ ) which causes it to be detected as background, not image.

## 2.5.5 Black Level Correction (Line mode only)

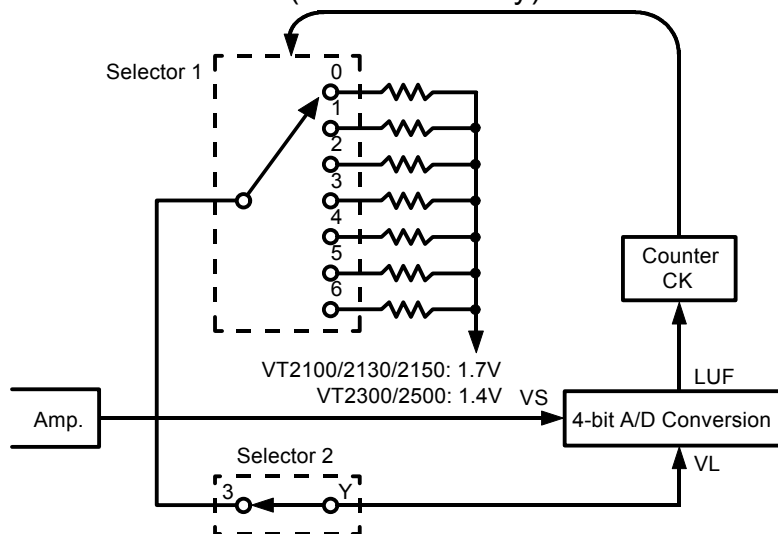

The black level correction compensates for the image density. Black level correction is used only when in line mode.

The lower threshold level ( $V_L$ ) of the A/D converter is set according to a high density original or a low density original.

At first, the black level reference of the A/D converter is set to 35% of the original peak hold white level ( $P_H$ ) because the analog switch of selector-1 is set to the "0" position.

If while reading the original image the black level of the image is lower than  $V_L$  ( $P_H \times 35\%$ ), the A/D converter outputs the LUF signal.

The LUF signal is applied to selector 1 as a clock pulse. The LUF signal increments the counter of selector 1 from 0 to 1. This changes the  $V_L$  to 30% of  $P_H$ . If the LUF signal is again applied to the counter of selector 1, incrementing it from 1 to 2, the analog switch of selector 1 changes from 0 to 1.

The following table shows the number of clock pulses needed to increment the analog switch of selector 1.

Counter (4 bit)	Selector 1 Switching	$V_L$
0.1	SW 0	$P_H \times 35\%$
2.3	SW 1	$P_H \times 30\%$
4.5	SW 2	$P_H \times 25\%$
6.7	SW 3	$P_H \times 20\%$
8.9	SW 4	$P_H \times 15\%$
A.B	SW 5	$P_H \times 10\%$
C.D	SW 6	$P_H \times 5\%$
E.F	SW 7	$P_H \times 0\%$ (Black Level)

## 2.5.6 A/D Conversion

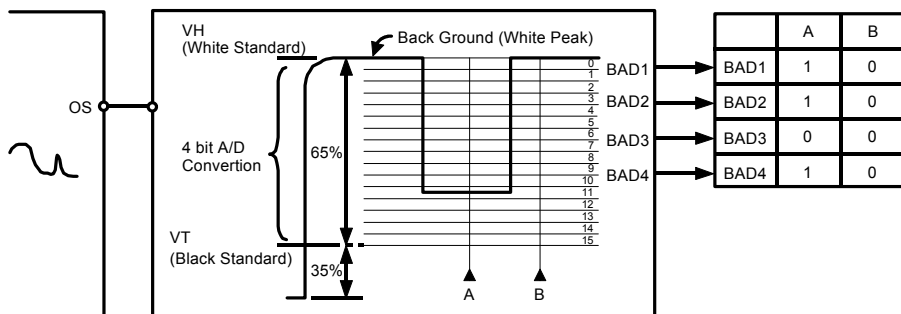

## VT2100/VT2130/VT2150 Circuit:

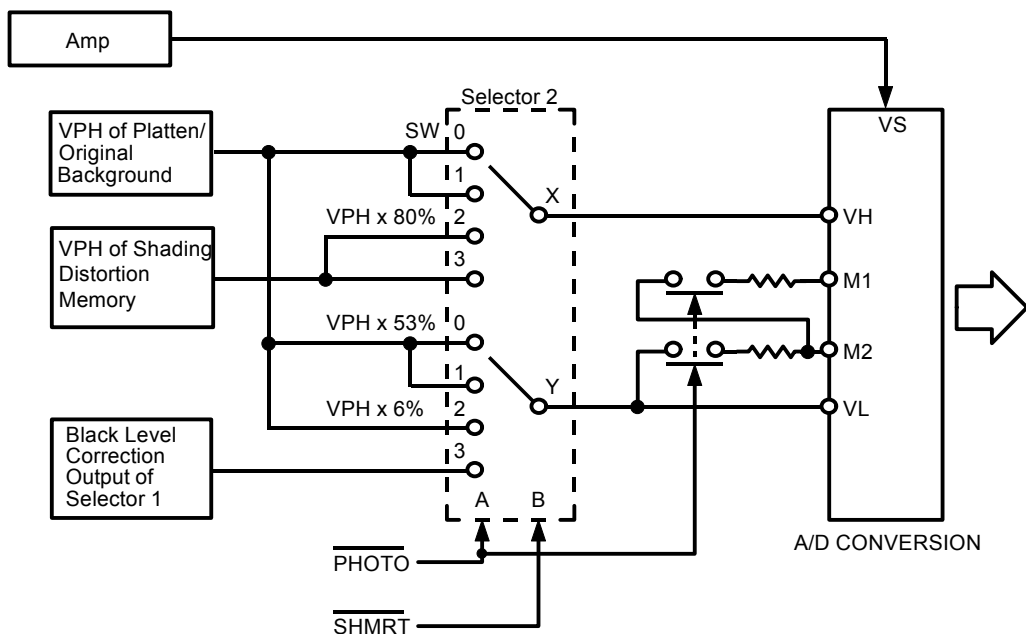

	$\overline{\text{PHOTO}}$	$\overline{\text{SHMRT}}$	Selector 2 (X, Y)
Shading Distortion Correction (Photo Mode)	L	L	SW0 ON
Shading Distortion Correction (Line Mode)	H	L	SW1 ON
Photo Mode	L	H	SW2 ON
Line Mode	H	H	SW3 ON

This circuit converts the analog input signal ( $V_s$ ) to a 4-bit digital signal using both the white level reference ( $V_H$ ) and the black level reference ( $V_L$ ).

In each mode, the settings of the "X" and "Y" switches in Selector 2 are automatically determined by the PHOTO and SHMRT signals as shown in the above table.

VT2300/VT2500 Circuit:

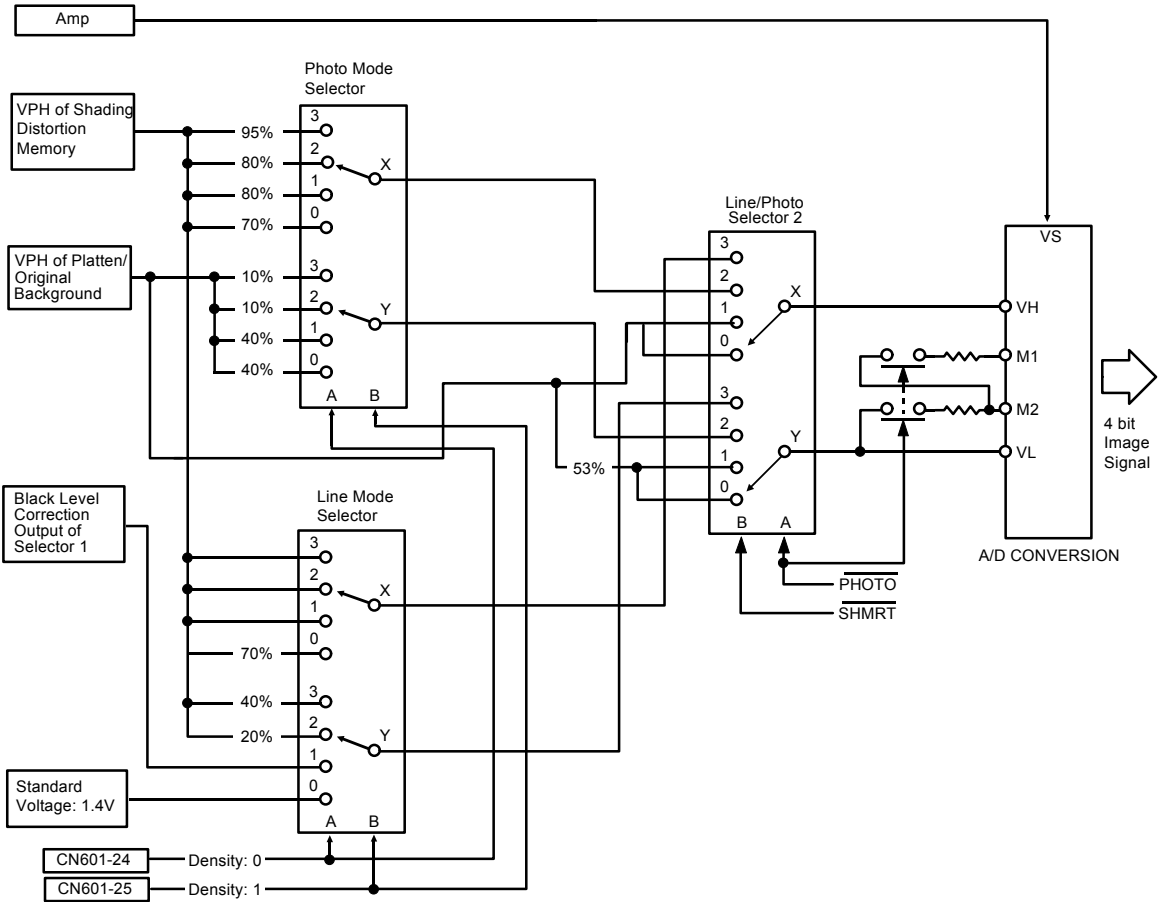

	$\overline{\text{PHOTO}}$	$\overline{\text{SHMRT}}$	Line/Photo Selector 2 (X, Y)
Shading Distortion Correction (Photo Mode)	L	L	SW0 ON
Shading Distortion Correction (Line Mode)	H	L	SW1 ON
Photo Mode	L	H	SW2 ON
Line Mode	H	H	SW3 ON

This circuit converts the analog input signal ( $V_s$ ) to a 4-bit digital signal using both the white level reference ( $V_H$ ) and the black level reference ( $V_L$ ).

In each mode, the settings of the "X" and "Y" switches in Selector 2 are automatically determined by the PHOTO and SHMRT signals as shown in the above table.

## 1). Shading Distortion Correction – (Selector 2 Switch 1 ON)

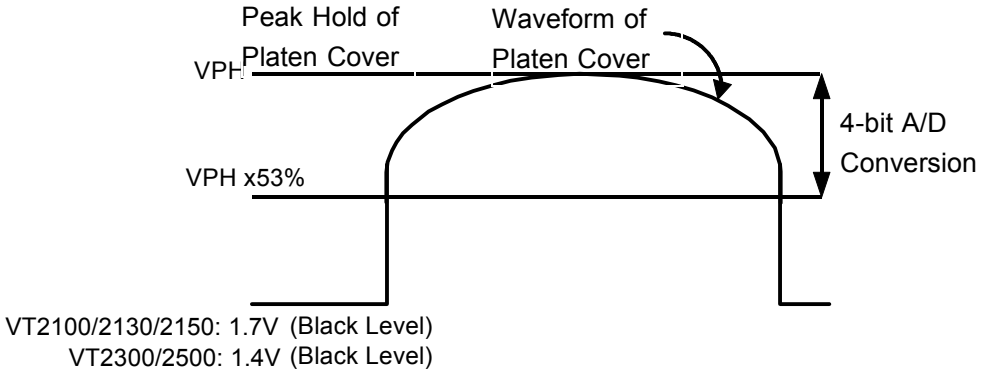

When reading the platen cover to establish the shading distortion data, the high reference voltage ( $V_H$ ) of the A/D converter is set to the peak hold level and the low reference voltage ( $V_L$ ) is set to 53 % of the peak hold level. Therefore, the potential difference between the output of each pixel and the 53% level of the peak hold is converted by the A/D converter into 4-bit data. The shading distortion data for each pixel is stored in a memory location corresponding to that pixel.

## 2). Original Reading

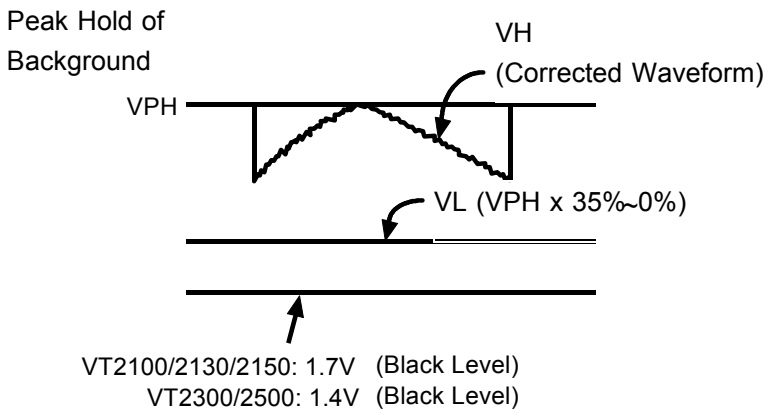

### a). Line Mode – (Selector 2 Switch 3 ON)

The reference voltage ( $V_H$ ) of the A/D converter is set to the output of the D/A converter (converted shading distortion data) for each pixel being read. Because the reference level of the D/A converter is set to the original peak hold level, this corrects for shading distortion as well as matching the output level to the original background.

Also, as described in "Black Level Correction",  $V_L$  is set from 0% to 35% of the potential difference between 1.7 volts (VT2300/2500: 1.4 volts) and the peak hold of the original background. Black level correction varies according to the original image density.



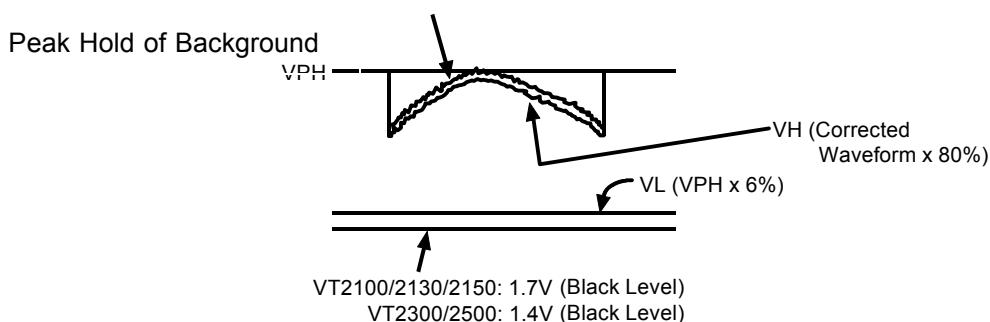

### b). Photo Mode – (Selector 2 Switch 2 ON)

The  $V_H$  of the A/D converter is set to 80% of the potential difference between 1.7 volts (VT2300/2500: 1.4 volts) and the output from the D/A converter (converted shading distortion data). This corrects for shading distortion as well as matching the output level to the original background because the reference level of the D/A converter is set to the original peak hold level.

Also,  $V_L$  is set to 6% of the potential difference between 1.7 volts (VT2300/2500: 1.4 volts) and the peak hold level of the original.

## 2.5.7 Printing Density Change

### VT2100/VT2130/VT2150 Circuit in Line mode:

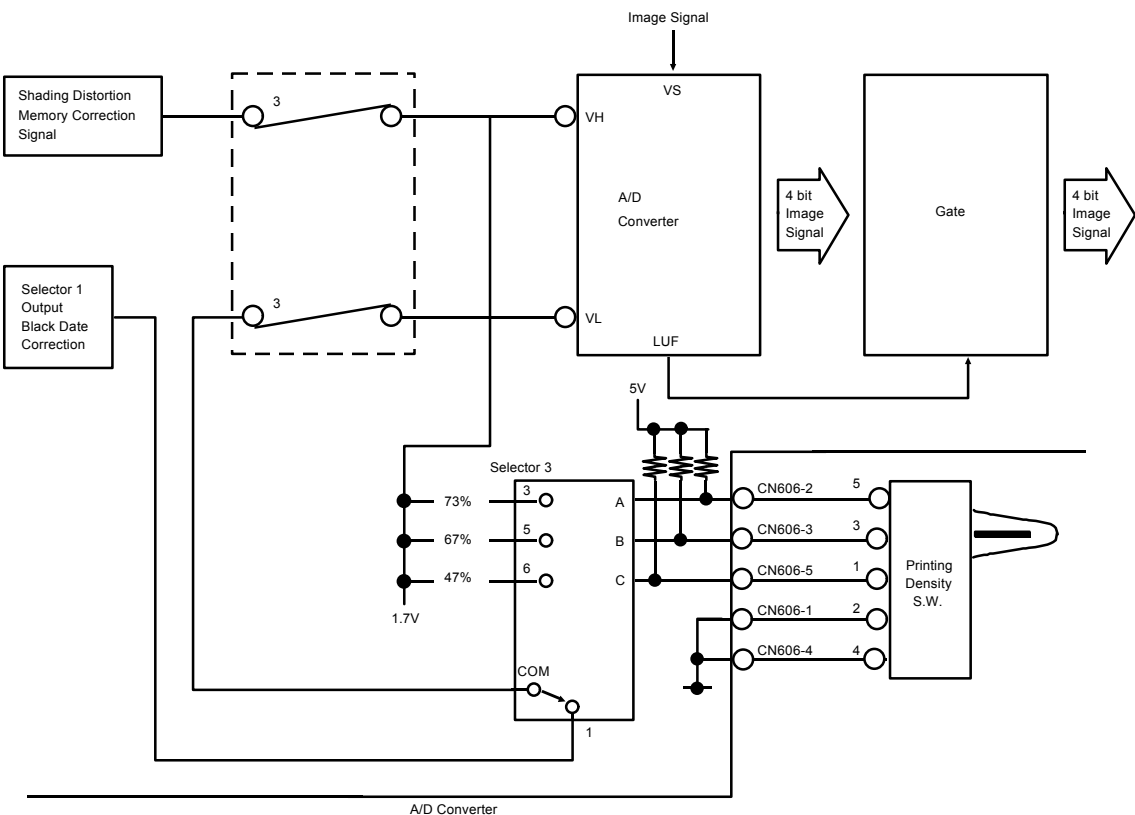

	SW ON (Terminal No.)	CN606			Selector 3
		-2	-3	-5	
MANUAL 1	1-2	H	H	L	COM-3
MANUAL 2	2-3	H	L	H	COM-5
Standard	—	H	H	H	COM-1
MANUAL 3	4-5	L	H	H	COM-6

The printing density can be changed by the printing density switch when in the line mode. This switch changes the threshold level to 47 %, 67 %, or 73 % of the white level.

The selected threshold level enters port VL while the shading distortion corrected image signal enters port VH of the A/D converter.

In manual printing density mode (Dark, Darker, and Lighter), the A/D converter outputs either all "H" BAD signals (4 bit) or all "L" BAD signals (4 bit). This is determined by the LUF signal

When the image signal is lower than the threshold level, the LUF signal is output from the A/D converter to make all BAD signals "H". Then the image signal is output as a black.

When the image signal is higher than threshold level, LUF signal is not output. Then the BAD signals are all "L".

VT2300/VT2500 Circuit in Line Mode:

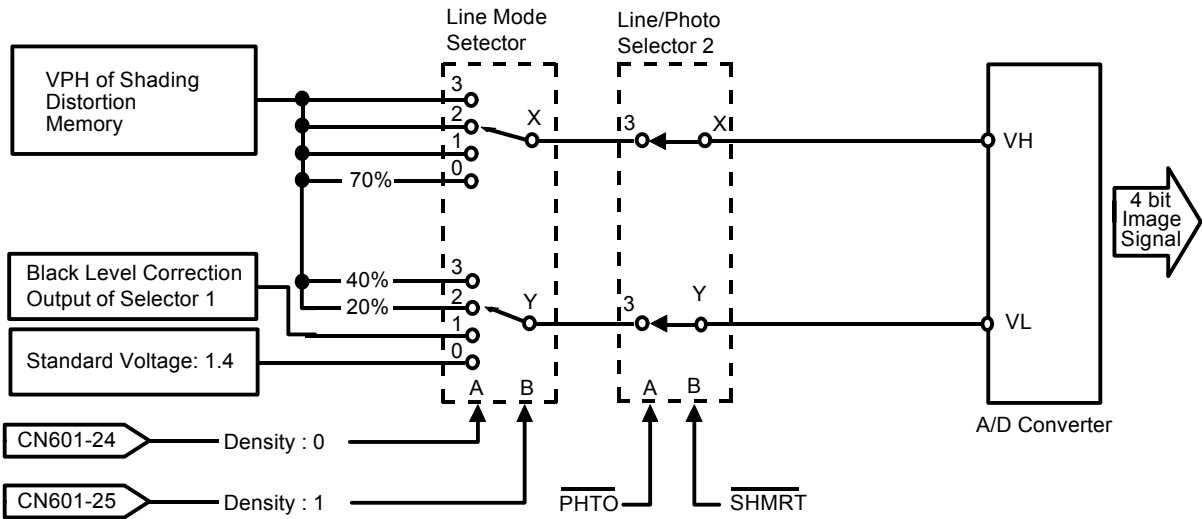

The printing density (i.e. image density) can be changed with the Printing Density key on the operation panel.

Line Mode Selector changes the threshold level of VH (White level reference) and VL (Black level reference) according to the density signals from CN 601-24 and CN 601-25.

The A/D converter converts the analog input signal to a 4-bit digital signal using both the white reference level (VH) and the black reference level (VL).

The following table shows the VH and VL levels that vary according to the combination of the density signals in Line mode.

Printing Density	Density Signal 0 (CN601-24)	Density Signal 1 (CN601-25)	Line Mode Selector ON Channel.	A/D Converter	
				VH	VL
Darker 2	H	H	0X, 0Y	100%	40%
Darker 1	L	H	1X, 1Y	100%	20%
Standard	H	L	2X, 2Y	100%	0~35%
Lighter	L	L	3X, 3Y	70%	0%

## VT2300/VT2500 Circuit in Photo Mode:

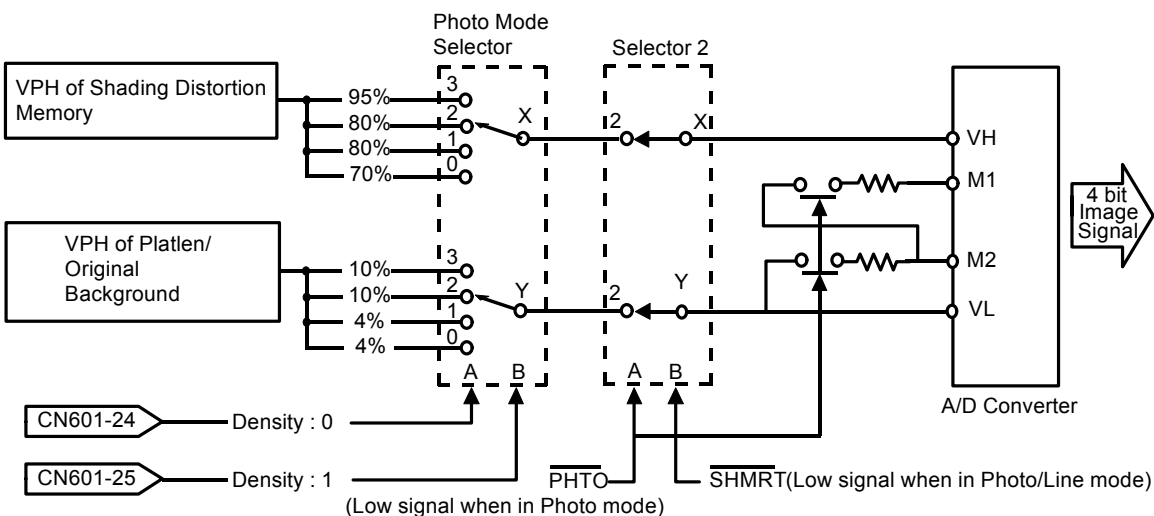

The printing density (i.e. image density) can be changed with the Printing Density key on the operation panel. This adjustment can also be done in Photo mode to increase the image quality of photo originals.

Photo mode Selector changes the threshold level of VH (White level reference) and VL (Black level reference) according to the density signals from CN 601-24 and CN 601-25.

The A/D converter converts the analog input signal to a 4-bit digital signal using both the white reference level (VH) and the black reference level (VL).

The following table shows the VH and VL levels that vary according to the combination of the density signals in Photo mode.

Printing Density	Density Signal 0 (CN601-24)	Density Signal 1 (CN601-25)	Photo Mode Selector ON Channel.	A/D Converter	
				VH	VL
Darker 2	H	H	0X, 0Y	95%	10%
Darker 1	L	H	1X, 1Y	80%	10%
Standard	H	L	2X, 2Y	80%	4%
Lighter	L	L	3X, 3Y	70%	4%

## 2.6 REDUCTION PROCESSING:

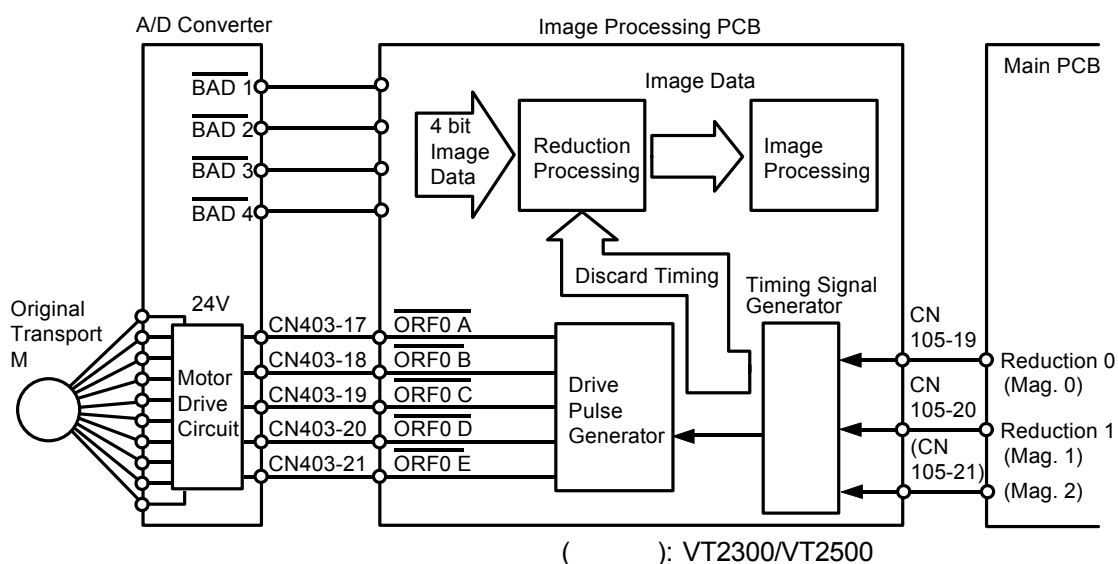

CN-NO	Signal	I/O	FROM	100 %	93 %	82 % [75%]	71 % [64%]
105-19	Reduction 0 (Magnification 0)	I	Main PCB	H	L	H	L
105-20	Reduction 1 (Magnification 1)	I	Main PCB	H	H	L	L
(105-21)	(Magnification 2)	(I)	(Main PCB)	(H)	(H)	(H)	(H)

( ): VT2300/VT2500

Reduction in the main scanning direction is performed by systematically discarding the pixels and the reduction in the sub-scanning direction is performed by changing the transportation speed of the original.

### 2.6.1 Main Scanning Reduction:

Reduction Mode	Discarded Pixels	Remaining Pixels
100 %	0 Pixels	All Pixels
93 %	1/14 Pixels	13/14 Pixels (0.929)
82 % (A4 version)	3/11 Pixels	9/11 Pixels (0.818)
75 % (LT version)	1/4 Pixels	3/4 Pixels (0.75)
71 % (A4 version)	2/7 Pixels	5/7 Pixels (0.714)
64 % (LT version)	5/14 Pixels	9/14 Pixels (0.642)

When the reduction command is sent from the main board, the timing signal generator sends the thinning timing control signal to the reduction

processing circuit. Some of the 4-bit image data from the A/D converter is discarded according to the thinning timing control signal.

### 2.6.2 Movement:

#### Main scan direction: Examples (A4 version)

During the 71% reduction mode, 5 out of 7 pixels are used; 1 pixel is discarded each cycle.

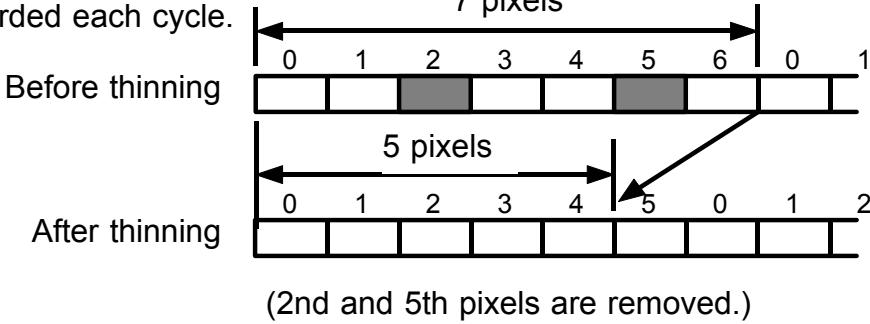

During the 82% reduction mode, 9 out of 11 pixels are used; 2 pixels are discarded each cycle.

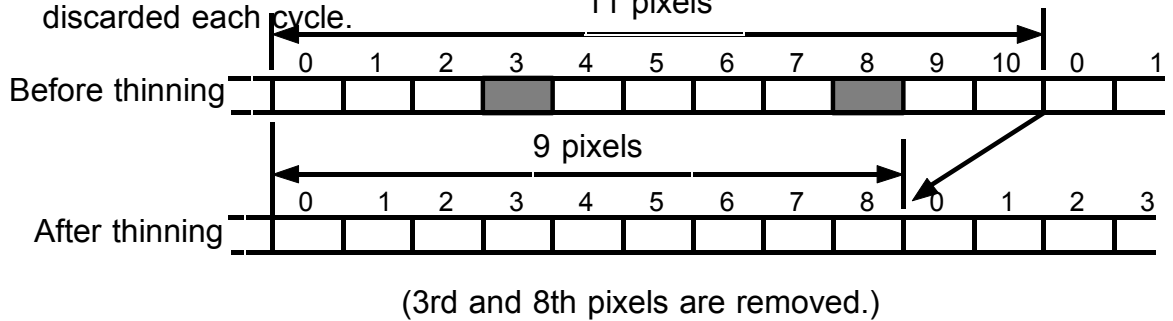

During the 93% reduction mode, 13 out of 14 pixels are used; 1 pixel is discarded each cycle.

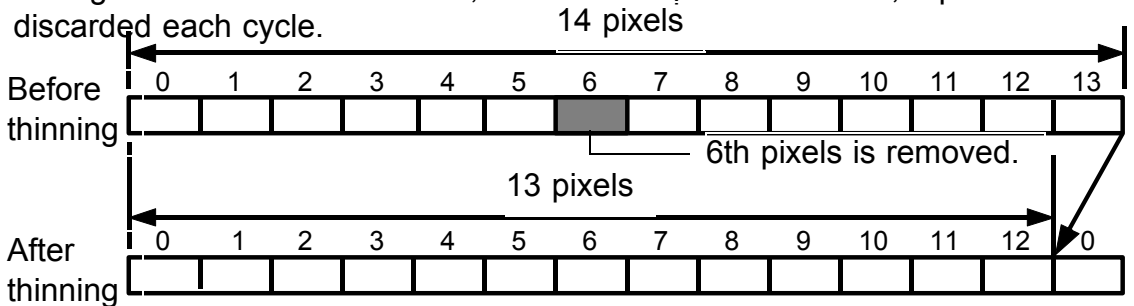

### 2.6.3 Sub-scanning Reduction:

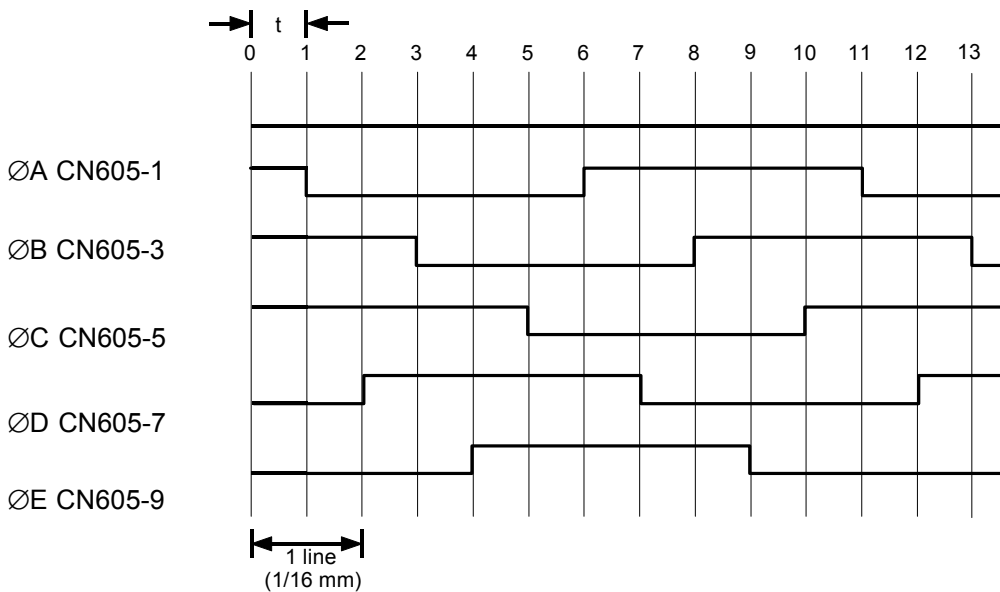
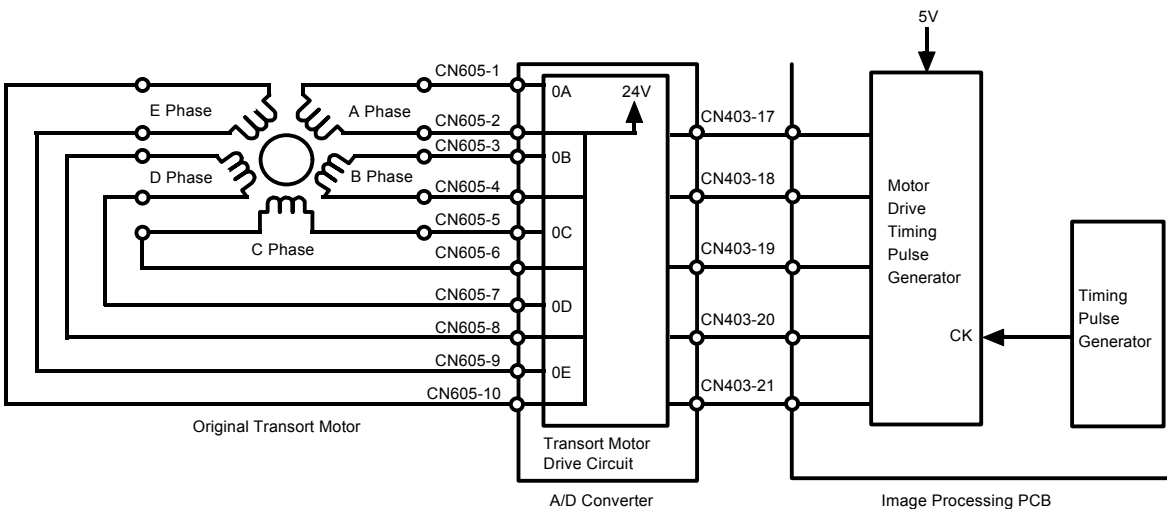

NOTE: The reduction ratio change is performed by changing the pulse width "t".

Reduction Ratio	Original Transportation			Command Sheet Transportation		
	Pulse Width	PPS		Pulse Width	PPS	
100%	1.484 ms	674	—	0.742 ms	1348	—
93%	1.378 ms	726	$\frac{674}{726} = 0.928$	0.689 ms	1451	$\frac{1348}{1451} = 0.928$
82%	1.214 ms	824	$\frac{674}{824} = 0.818$	0.607 ms	1648	$\frac{1348}{1648} = 0.818$
75%	1.112 ms	899	$\frac{674}{899} = 0.74$	0.556 ms	1798	$\frac{1348}{1798} = 0.749$
71%	1.060 ms	944	$\frac{674}{944} = 0.714$	0.530 ms	1888	$\frac{1348}{1838} = 0.714$
64%	0.950 ms	1053	$\frac{674}{1053} = 0.64$	0.475 ms	2106	$\frac{1348}{2106} = 0.640$

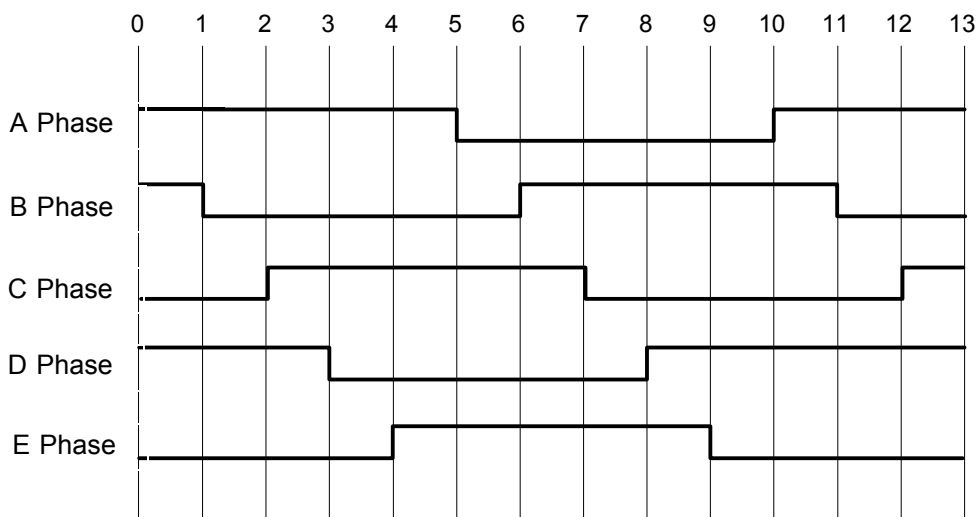

When the reduction command is sent from the main board, the frequency of the pulses from the pulse generator increases. The drive pulse generator then increases the frequency of the motor drive pulses to increase the motor rotation speed.



## 2.7 Enlargement Processing: VT2300/VT2500

In reduction processing, pixels are discarded according to the selected reduction ratio. In enlargement processing, pixels are added.

Enlargement processing requires main scanning enlargement and sub-scanning enlargement.

**Main Scanning :** Main scanning is performed by systematically adding pixels according to the enlargement ratio.

**Sub-Scanning :** Sub-scanning is performed by changing the original transportation speed according to the enlargement ratio.

### 2.7.1 Main Scanning Enlargement

When the magnification command is sent from the main control board (CN402-19, 20, 21), the timing signal generator in the image processing board sends the adding timing control signal. Pixels are added to the 4-bit image data from the A/D converter according to the adding timing control signal.

Enlarge Mode	Added Pixels	Pixel Ratio
115% (LT/A4 Version)	2 Pixels	15/13 Pixels (1.154)
122% (A4 Version)	3 Pixels	17/14 Pixels (1.214)
127% (LT Version)	3 Pixels	14/11 Pixels (1.273)
141% (LT/A4 Version)	9 Pixels	31/22 Pixels (1.409)

## Examples:

In 115% enlarge mode, the 7th pixel and the 13th pixel data are doubled to produce 15 pixels. This is repeated each main scan cycle.

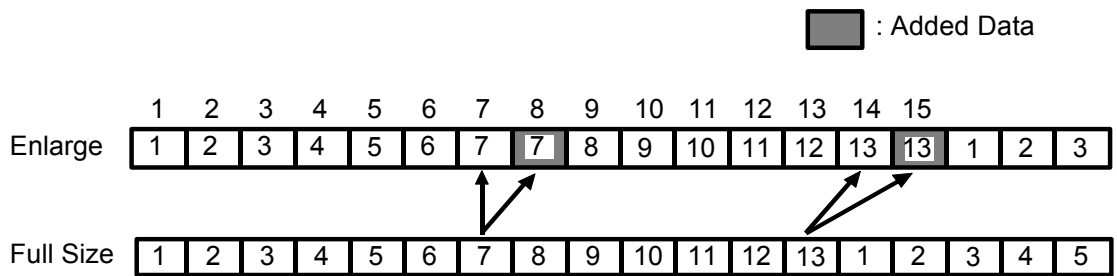

In 122% enlarge mode, the 5th, 10th, and 14th pixels are doubled to produce 17 pixels. This is repeated each cycle.

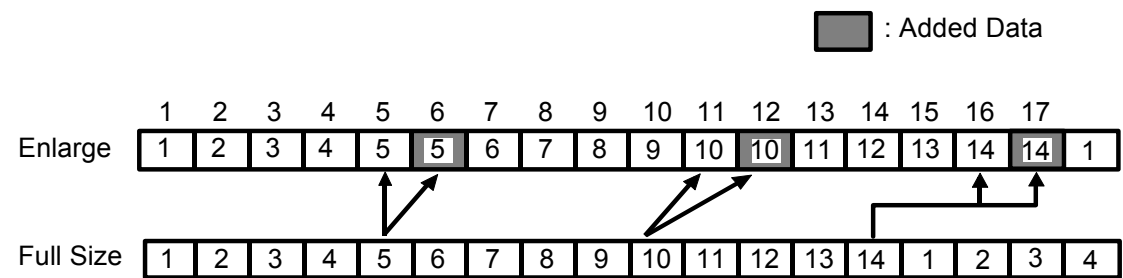

In 127% enlarge mode, the 4th, 8th and 11th pixels are doubled to produce 14 pixels. This is repeated each cycle.

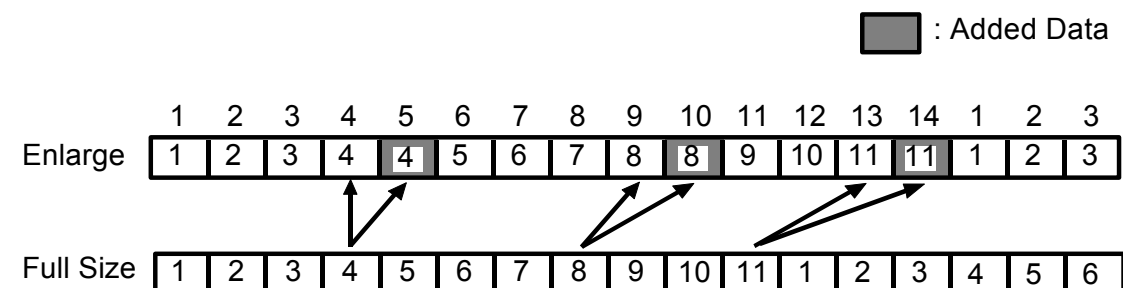

In 141% enlarge mode, the 3rd, 5th, 8th, 10th, 13th, 15th, 18th, 20th, and 22nd pixels are doubled to produce 31 pixels. This is repeated each cycle.

■ : Added Data

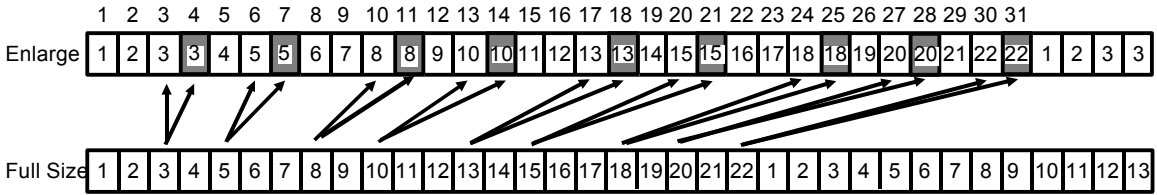

## 2.7.2 Sub-scanning Enlargement

Enlargement in the sub-scanning direction is performed by decreasing the original transportation speed.

When the enlargement signal is sent from the main control board, the frequency of the pulses from the pulse generator decreases. (The pulse length increases.) The drive pulse generator then decreases the frequency of the motor drive pulses to decrease the motor rotation speed.

## 2.8 IMAGE SIGNAL PROCESSING : BINARY CIRCUIT

The binary circuit produces 1-bit data (white or black) from the output of the A/D converter (four-bit data) and sends it to the thermal head board.

### 2.8.1 Function

- 1) Line Mode:  
MTF (Modulation Transfer Function) Correction Processing
- 2) Photo Mode:  
Dither Processing (Graduation Processing) - 16 graduations  
Edge Emphasis Processing (Selection of either MTF or Dither processing)

### 2.8.2 Outline

- 1) MTF Correction Processing

This is used to emphasize image signal data compared with surrounding pixels. Emphasis data which varies according to the surrounding pixels is compared to a fixed threshold level to determine if the pixel is white or black.

When the surrounding pixels are whiter than the pixel being processed E , the pixel data E is converted to appear darker than the real pixel data. This converted data is termed the emphasis data.

Conversely, when the surrounding pixels are darker than the pixel being processed E , the pixel data E is converted to appear whiter than the real pixel data.

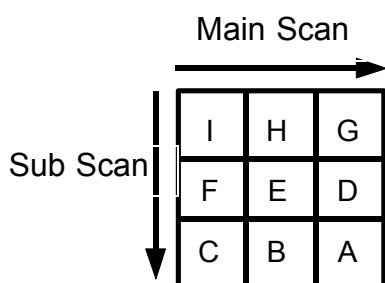

$$E_2 = 2E - 1/2(D + F) \quad \text{----- Main Scan Emphasis Data}$$

$$E_1 = 2E - 1/2(B + H) \quad \text{----- Sub Scan Emphasis Data}$$

The emphasis data is compared to a threshold level to determine if the pixel is black or white.

$$\text{Emphasis Data } E_2 \text{ or } E_1 \geq 7.5 \quad \text{---- Black}$$

$$\text{Emphasis Data } E_2 \text{ or } E_1 < 7.5 \quad \text{---- White}$$

## 2) Dither Processing

This is part of the artificial graduation system. As each pixel can only be expressed by either black or white at print time, the dither process is used to transform a graduated original into 4 x 4 arrays containing only black and white pixels. Each pixel of the original corresponds to a location in the 4 x 4 dither matrix. During dither processing, the value of each four-bit data signal from the A/D converter is compared to the corresponding fixed threshold level ( $V_{TH}$ ) in the dither matrix and is converted to either black or white. This introduces graduations by changing the ratio of black pixels to white pixels. The 4 x 4 dither matrix is stored in the image processing ROM.

NOTE: The VT2300/2500 uses a 6 x 6 dither matrix that improves the image quality in Photo mode.

(The VT2100/2130/2150 use a 4 x 4 dither matrix.)

$E > V_{TH}$  ..... Black

$E \leq V_{TH}$  ..... White

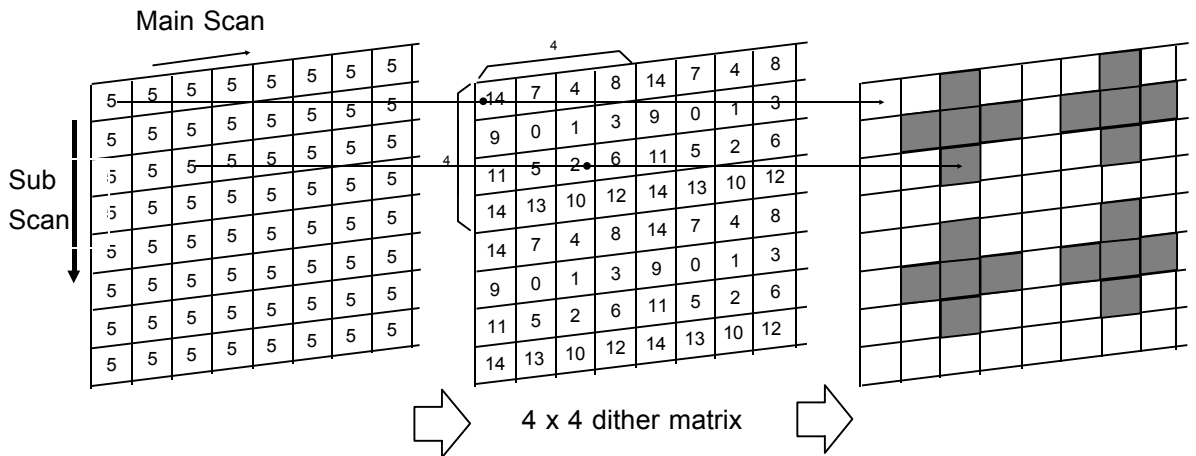

Pixels 4-bit data to be read  
Example: All pixels are at 5.

Threshold level of the  
dither matrix (Number  
shows each  $V_{TH}$ ).

Image reappearance  
(Shaded pixels are  
black.)

## 3) Selection of Dither Processing or MTF Correction During Photo Mode (Edge Emphasis)

If characters are processed using the dither method, they will be disjointed and difficult to read due to the distorting nature of the dither process. Therefore, when the density difference between a pixel and the surrounding pixels is greater than the specified level, the data is processed using MTF instead of the dither method.



### 1) Thermal Head Resistance

The resistance of the thermal head varies from one head to the another. Therefore, after installing a new thermal head, always recalibrate the power supply unit according to the VHD ratings on the thermal head cover.

### 2) Head Temperature

The thermal head contains a thermistor, which it detects the thermal head temperature.

The detected temperature is sent to the pulse generator by a divided rank signal.

Rank	1	2	3	4	5	6	7
Head Temp.	~ 8.5°C	~ 12°C	~ 15.5°C	~ 19°C	~ 22.5°C	~ 26°C	~ 29.5°C
	8	9	10	11	12	13	14
	~ 33°C	~ 36.5°C	~ 40°C	~ 43.5°C	~ 47°C	~ 50.5°C	~ 54°C

3) The pulse generator controls the pulse width based on the above thermal head resistance information and the head temperature information.

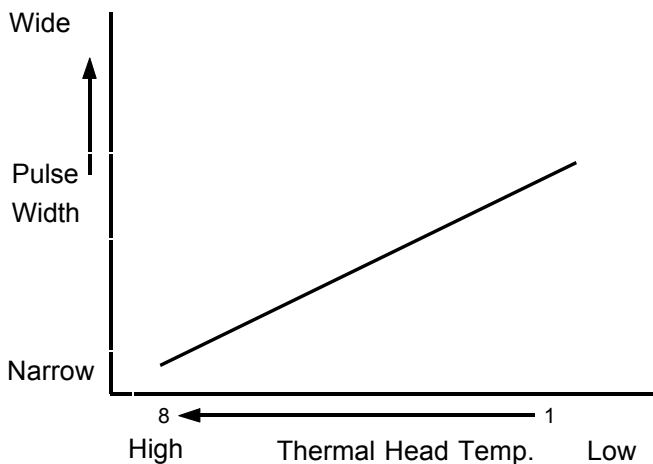



## 2.10 THERMAL HEAD DRIVE:

### 2.10.1 Function/Specification

The VT2130/VT2150 use the A4 size (216 mm width) thermal head and the VT2100/VT2300/VT2500 use the B4 size (256 mm width) thermal head.

Thermal head	Memory length	256mm (B4) 216 mm (A4/LG)
	Number of thermal heating elements	4096 dots (B4) 3456 dots (A4/LG)
	Density of thermal heating elements	16 dots/mm
	Applied Voltage	16V(14~18V)

### 2.10.2 Thermal Head Outline

A thin-film type thermal element is used in the thermal head. The drive circuit has a 1-line buffer for serial input. Each thermal element has direct drive due to switching elements.

S1 (S11—S18): White/Black pixel data

CK (CK1—CK4): To latch the shift register data

ENL: Record control

Va: Applied voltage (16V)

VDD: Power source (5V)

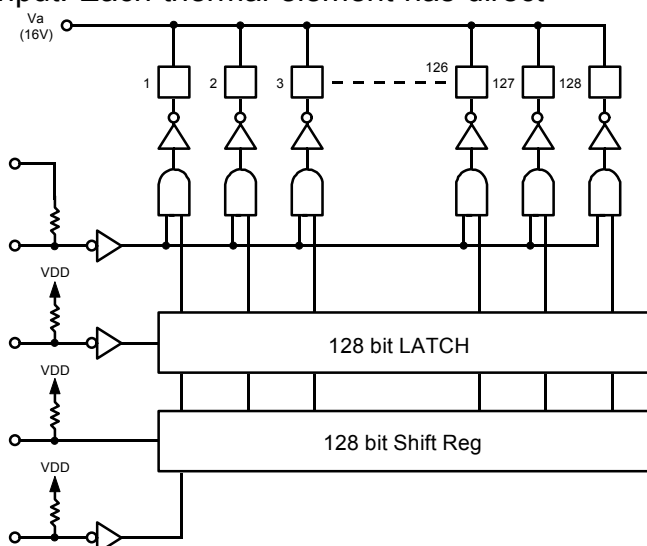

### 2.10.3 Power Lines

VCC/VHD/GND .... Applied voltage

VHD: As the resistance of the thermal elements varies depending on the thermal head, it is necessary to adjust the applied voltage according to the average resistance of the thermal head.

The thermal rating of each head is documented on the thermal head cover.

Therefore, after installing a new thermal head, always recalibrate the power supply unit according to the VHD ratings on the thermal head cover. Adjust VHD using VR201 on the power supply unit.

The drive circuit (LSIC) consists of the following: 32 x 128-bit shift registers, 32 x 128-bit latches, logic gates, drive transistors, and 4096 heating elements. The thermal head is made up of 32 drive circuits arranged in two rows of 16 elements.

NOTE: The thermal element used on the VT2130/VT2150 is narrower than the B4 thermal head. Therefore, the shift registers, latches, logic gates, and drive transistors located on both ends have been deleted from the thermal head.

## 2.10.4 Movement

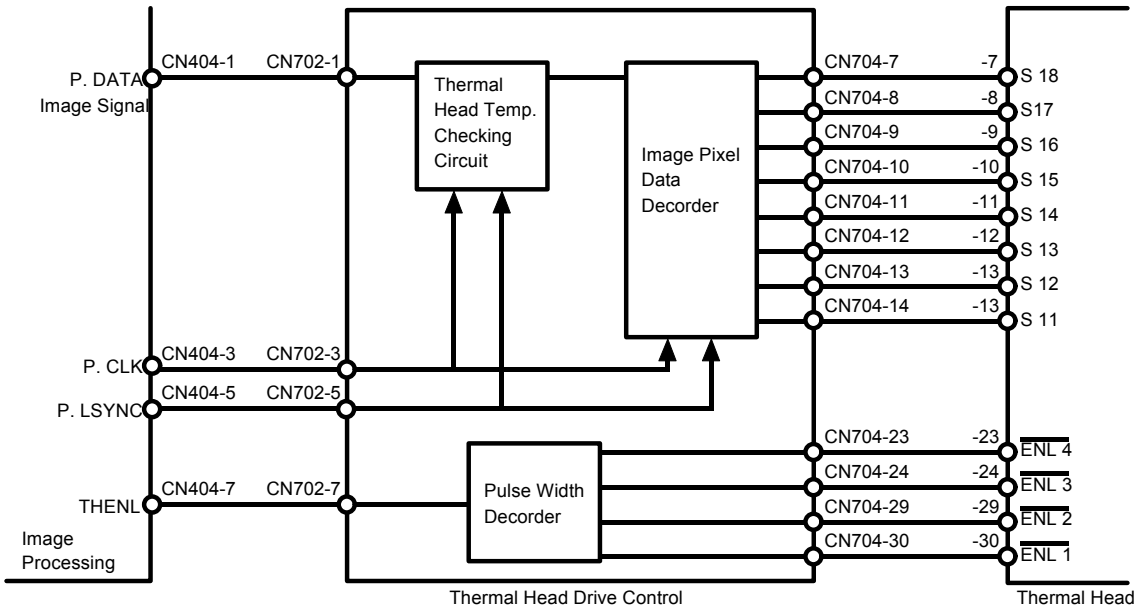

The temperature of the thermal head increases excessively when there is consecutive black image data in the sub scanning direction. Conversely, the temperature of the thermal head does not reach the proper point when there is consecutive white image data before a solid fill.

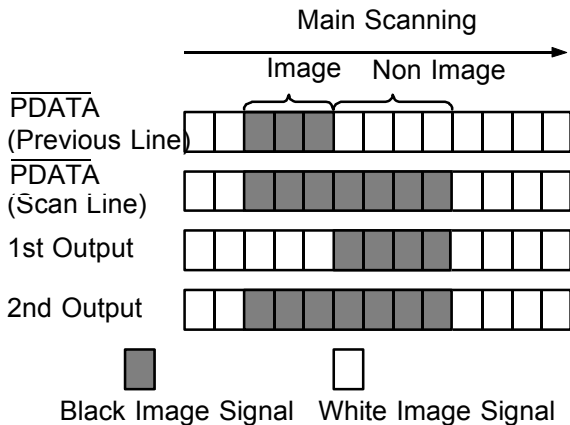

- White image in previous scanning.

The same black image signal is output twice.  
The first is for preheating.

- Black image in previous scanning.

A white image signal is output first to reduce the thermal head temperature.

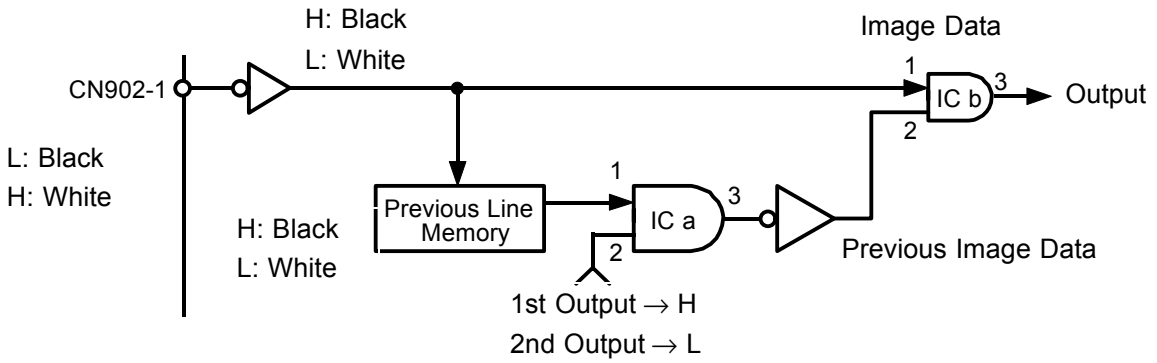

The image data (P-DATA) of 1 scanning sent to the thermal head drive control board is stored in the line memory. When the image data of the next scanning is stored in the line memory, the previous stored line memory data is output and processed with the image data of the next scanning at ICb.

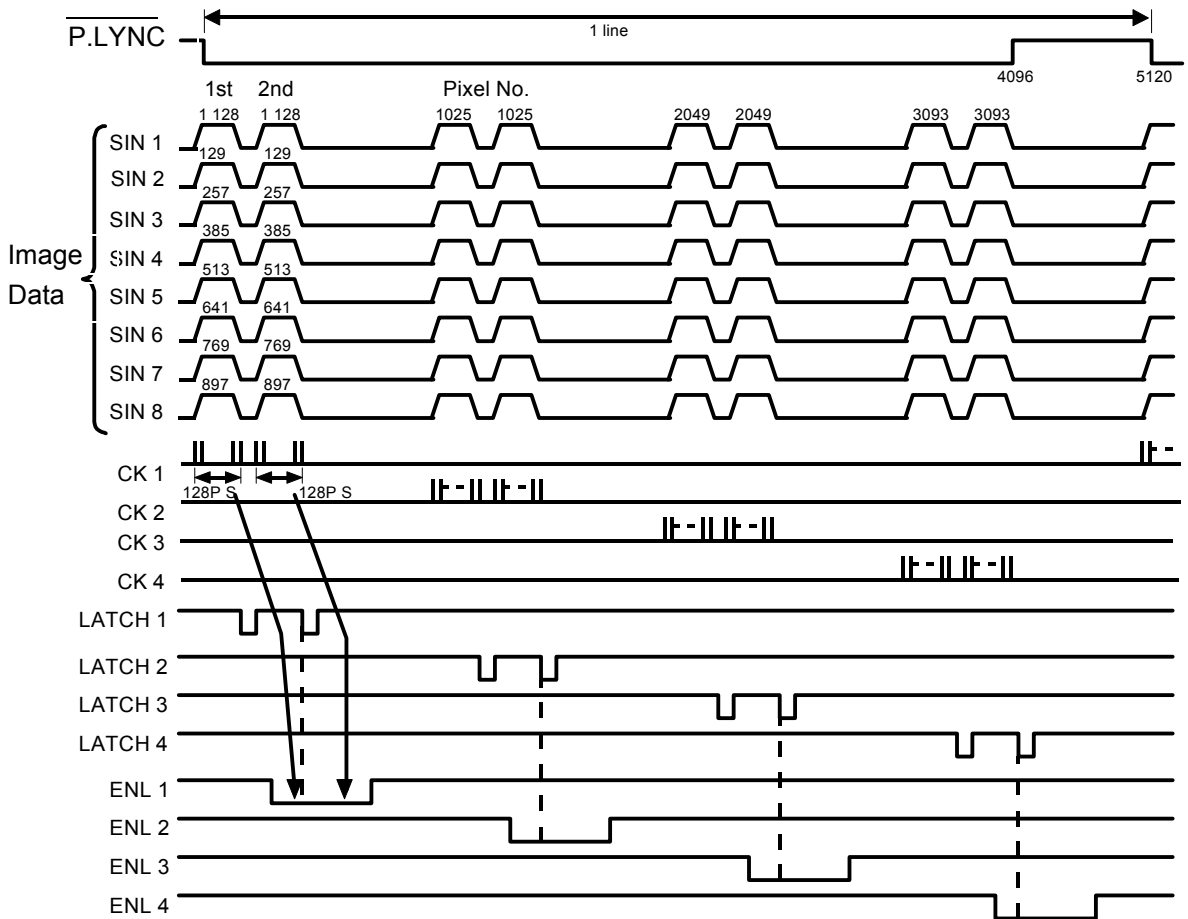

1. When the clock signals (CK1 – 4) enter the thermal head drive control board, the 1024 pixels of image data are input into the shift register. When the latch signal enters to the control board, the image data is sent from the shift register to the latch in parallel.
2. Above operation is performed again.
3. The image processing operation is performed when the ENL signal is low. The image data of the (1024 pixels each) main scan line is divided into 4 blocks.
4. The image signal for the preheat is sent to the thermal control twice. The first image signal responds to the first half of ENL low signal, and the second image signal responds to the later half of ENL low signal.

### 2.10.5 Temperature Rise Detection of Thermal Head/Power Supply:

A thermistor located on the thermal head and a thermal guard located on the power supply board are used for thermal protection. This is to prevent the temperature of the thermal head and the power supply board from overheating when continuously processing a solid image.

- 1). Thermal head detecting temp.           54°C
- 2). Thermal head return temp.           50°C
- 3). Power supply detecting temp.         85°C

When the thermistor is open, a detection signal is applied.

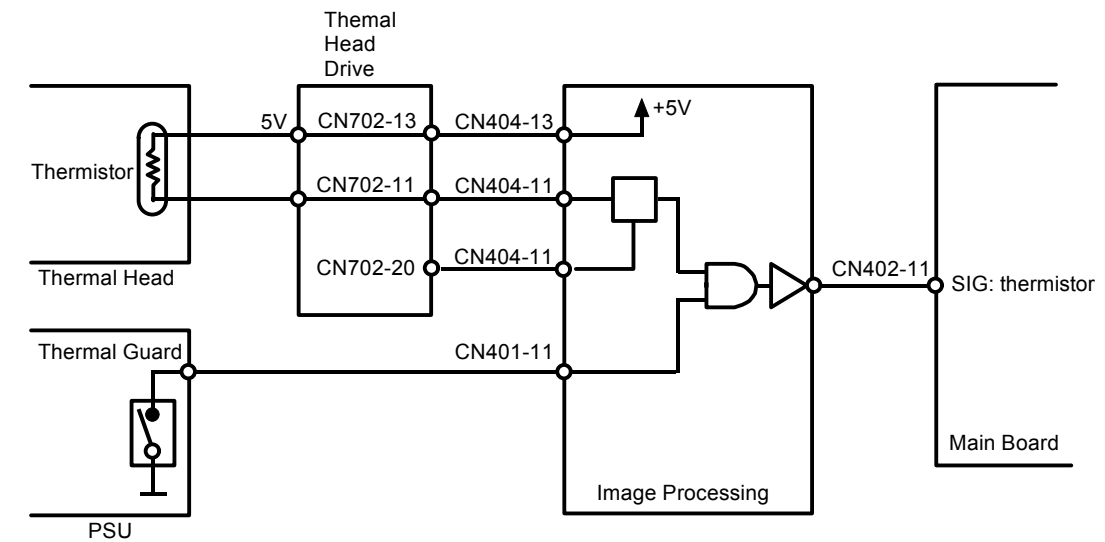

- 1). The thermal head temperature detection signal is applied if CN404-11 becomes greater than 3.13 volts (thermal head detecting temp.-- 54°C).

NOTE: Thermal head temperature detection signal is applied if the thermistor is open circuit.

- 2). The thermal head temperature return signal is applied when CN404-11 becomes 2.98 volts (Thermal head return temp.-- 50°C).
- 3). The thermal guard detection signal is applied if CN401-11 is 0 volt (Power supply detecting temp.-- 85°C).
- 4). The thermal guard temperature return signal is applied when CN401-11 becomes 5 volts.
- 5). When the temperature rise signal is applied, CN402-11 goes HIGH.

During the master making process, if the pulse width is out of standard, CN702-20 goes low and an error signal is applied to CN402-11. The master making stops and E-08 lights. The machine then stops after a master is wrapped around the drum.

If the thermal head temperature is still out of standard after the master making process, an error signal is applied to CN402-11. The machine stops and E04 lights.

If the power supply unit temperature is out of standard, the machine stops and E-04 or E-08 lights.

NOTE: During all processes other than the master making process, E-04 will light when the PSU temperature reaches 85°. During the master making process, E-08 will light when the PSU temperature reaches 85°.

## 2.11 MAKE-UP MODE: VT2500 only

### 2.11.1 Overall Operation

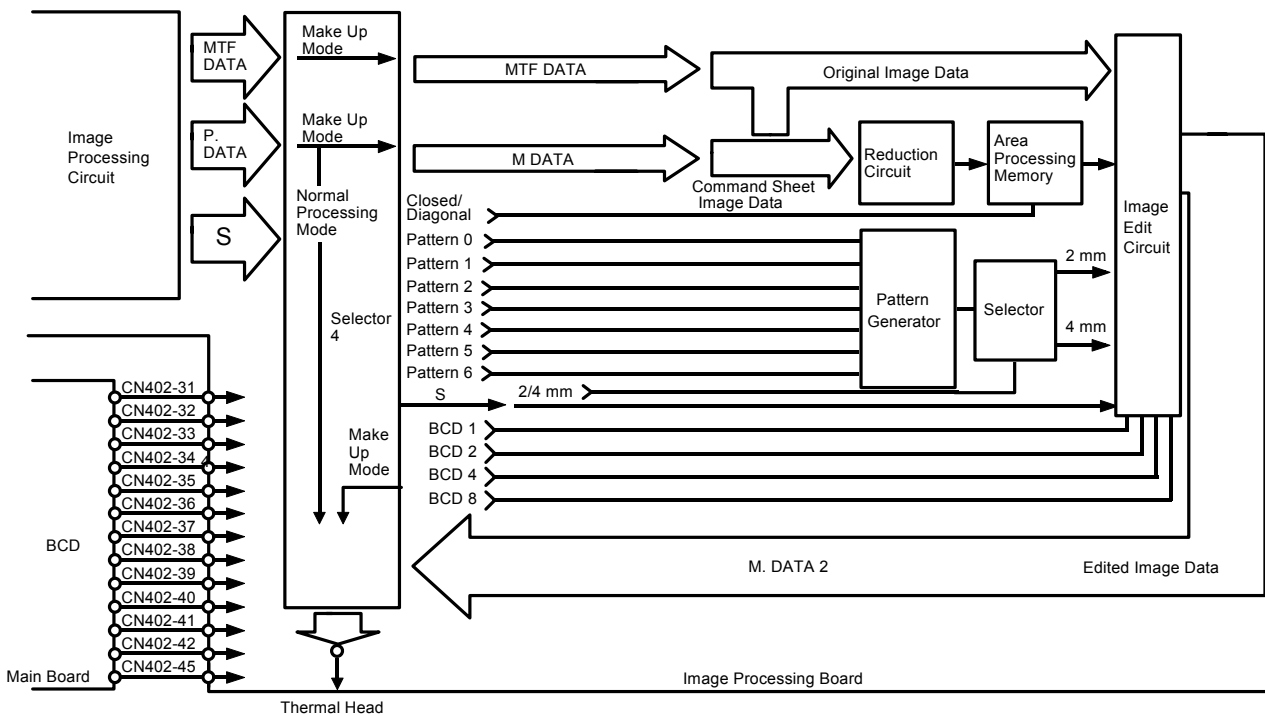

The command sheet is read twice as fast as the original. The command data is converted in the A/D converter and is modulated in the image processing circuit. The modulated command data is reduced to 1/64 and stored in the area memory. The area memory stores the command sheet area data as area solid fill data.

The image data read by CCD is also converted and is modulated. The modulated image data, the stored command area data, and the background pattern are edited in the editing circuit of the make up control board according to the editing command.

The edited image data is sent to the thermal head control board through the image processing board.

When the make-up mode is not selected, the modulated image data that was sent to the make-up control board is returned to the image processing board without any processing.

### 2.11.2 Command Sheet Data Reduction

The designated line data read from the command sheet is reduced to 1/64 and stored in the memory as shown in the illustration.

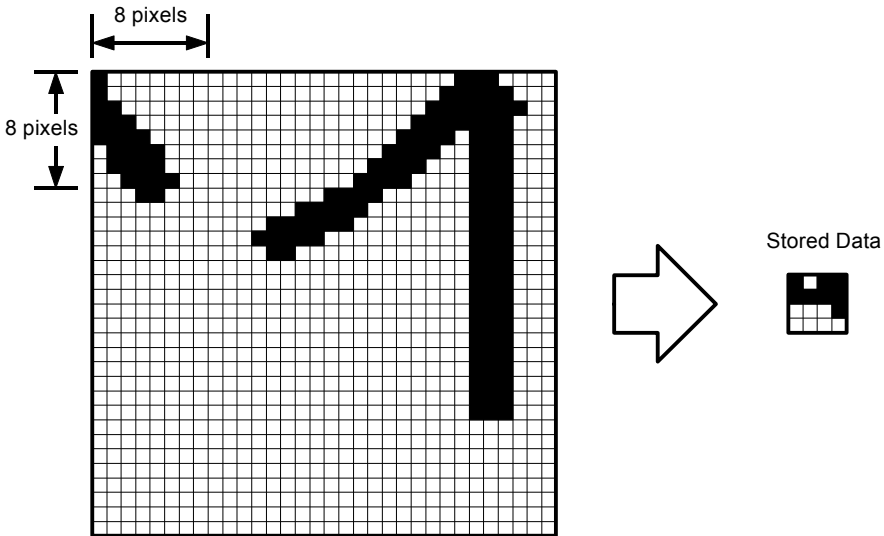

If any pixel in each of the 8 x 8 pixel squares is black, the square is stored as black data.

### 2.11.3 Designated Area Memory

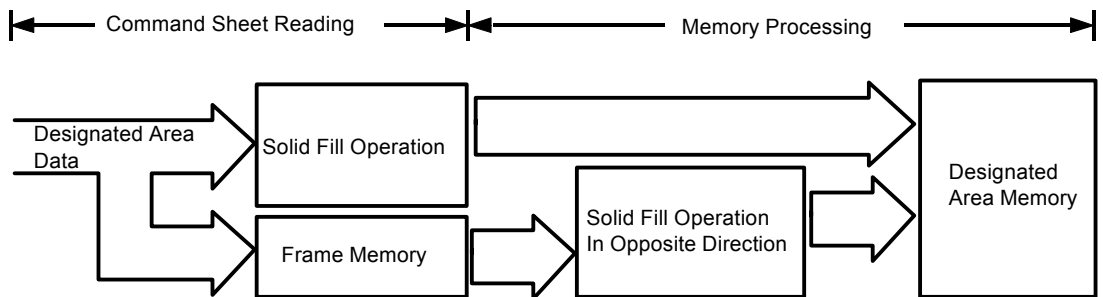

The designated area by the command sheet is stored in the memory as a solid fill area data.

The designated area is read in two directions. One is from the leading edge to the trailing edge and the other is from the trailing edge to the leading edge.



## 1). Solid Fill Operation (Closed Area)

How to decide whether pixel E data is black or white.

1. When pixel E is black, E is black.
2. When the pixel C or F is black and also the pixel D or G is black, E is black.
3. In all other cases, E is white.

NOTE: The above operation also acts in the opposite direction.

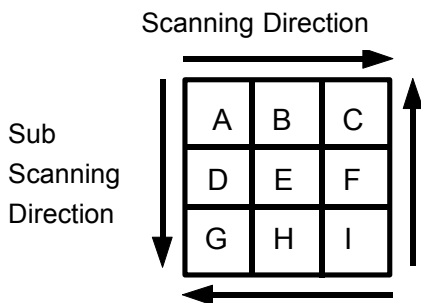

## 2). Solid Fill Operation (Diagonal Line)

How to decide whether pixel E data is black or white.

1. When the pixels B and D are black, Pixel E is black.
2. When the pixel E is black, the pixel E is black.
3. In all other cases, the pixel E is white.

NOTE: The above operation also acts in the opposite direction.

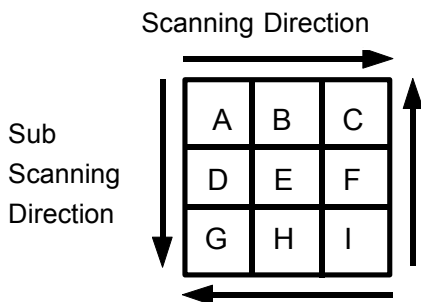

## 2.11.4 Make-up Control Circuit

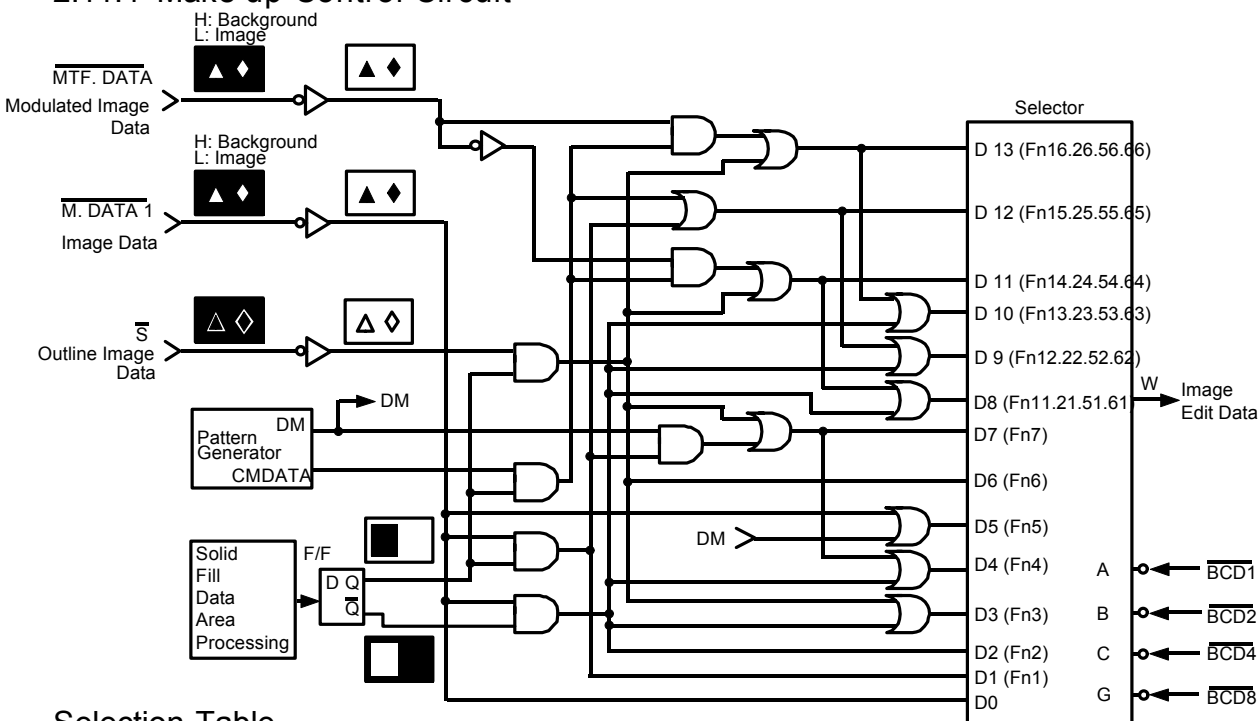

Selection Table

Make-up Selection Terminal	D0	D1	D2	D3	D4	D5	D6	D7	D8	D9	D10	D11	D12	D13
Make-up No	OFF	1	2	3	4	5	6	7	11.21 .51.61	12.22 .52.62	13.23 .53.63	14.24 .54.64	15.25 .55.65	16.26 .56.66
Input Signal														
BCD 1	H	L	H	L	H	L	H	L	L	H	L	H	L	H
BCD 2	H	H	L	L	H	H	L	L	H	L	L	H	H	L
BCD 3	H	L	H	H	L	L	L	L	H	H	H	L	L	L
BCD 4	H	H	H	H	H	H	H	H	L	L	L	L	L	L

The make-up control circuit on the image processing board edits the image using the above logic circuit.

The modulated image data, the outline image data, the background pattern data and the designated area data are processed simultaneously in the image processing board.

When the operator inputs a make-up number, the main board sends a 4-bit signal to the make-up control circuit.

The circuit selects the corresponding make-up selection terminal (D0~D13). This determines the path that image edit data takes before being output at the "W" terminal.

### Fn1: Save area

The image data is ANDed with the designated area data in command sheet and the edited image data is output.

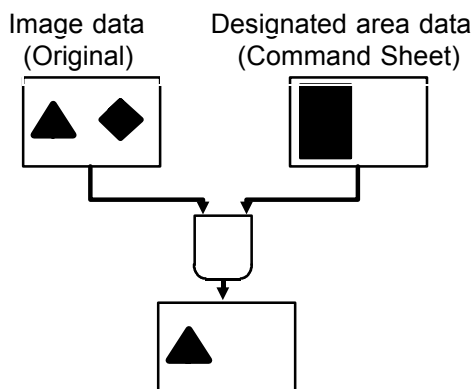

### Fn2: Delete area

The image data is ANDed with the inverted data of designated area and the edited image data is output.

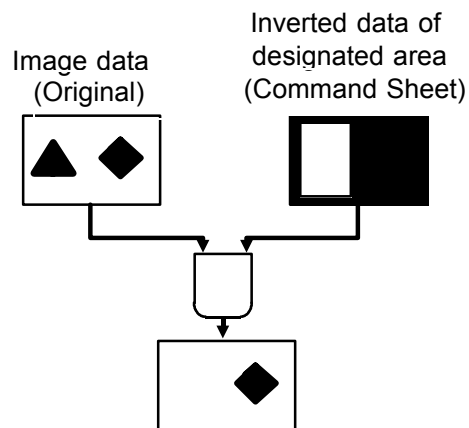

### Fn3: Outline Image

Step 1:  
The outline image data is ANDed with the designated area data and the edited image data is output.

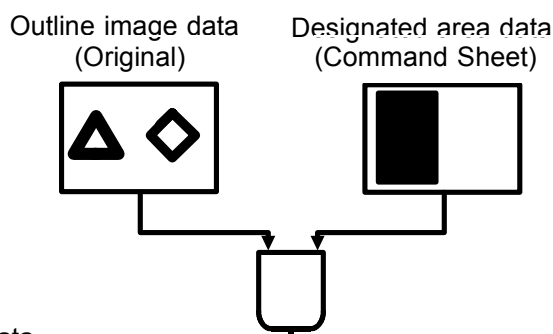

Step 2:  
The Fn2 data is ORed with the step 1 data and the edited image data is output.

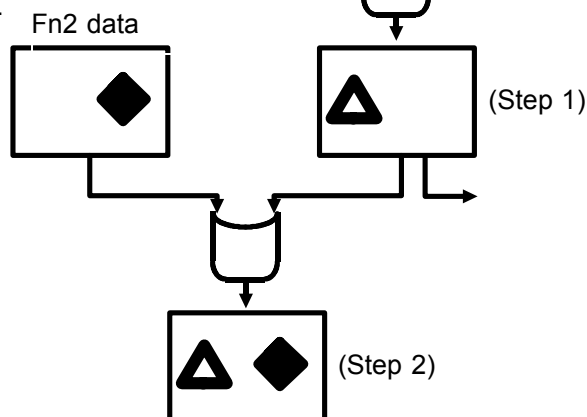

## Fn4: Screen Image

### Step 1:

This image data is ANDed with the designated area data and the edited image data is output.

### Step 2:

The screen pattern data is ANDed with the step 1 data and the edited image data is output.

### Step 3:

The Fn3 (step 1) data is ORed with the step 1 data and also ORed with the Fn2 data, and the edited image data is output.

## Fn5: Photo Image

The designated area is processed by the photo mode processing.

The non designated area is processed by the line mode processing.

Above processing is performed independent of the image mode selection on the operation panel.

## Fn6: Save area and Outline image

The outline image data is ANDed with the designated area data and the edited image data is output.

## Fn7: Save area screen image

### Step 1:

The screen pattern data is ANDed with the Fn1 data and the edited image data is output.

### Step 2:

The Fn3 (step 1) data is ORed with the step 1 data and the edited image data is output.

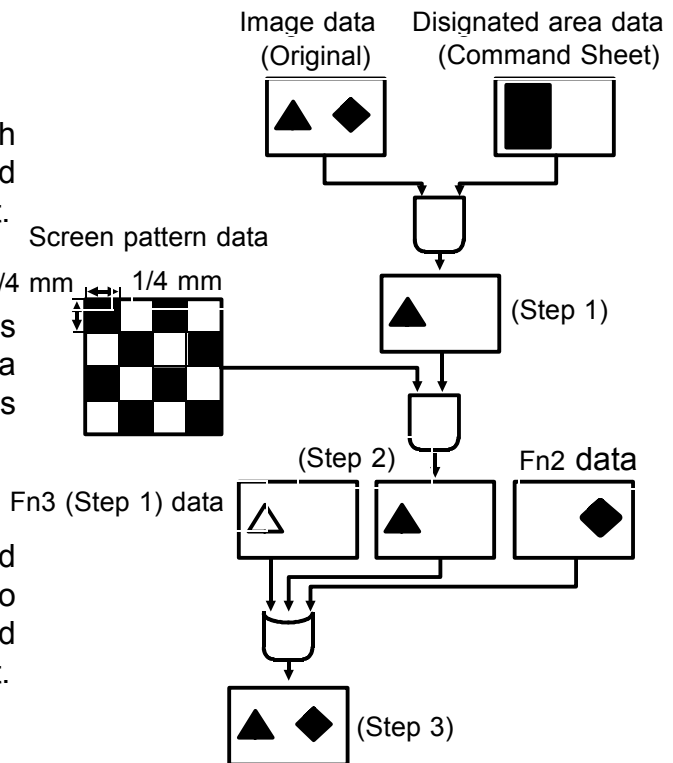

The designated area is processed by the photo mode processing.

The non designated area is processed by the line mode processing.

Above processing is performed independent of the image mode selection on the operation panel.

## Fn6: Save area and Outline image

The outline image data is ANDed with the designated area data and the edited image data is output.

## Fn7: Save area screen image

### Step 1:

The screen pattern data is ANDed with the Fn1 data and the edited image data is output.

### Step 2:

The Fn3 (step 1) data is ORed with the step 1 data and the edited image data is output.

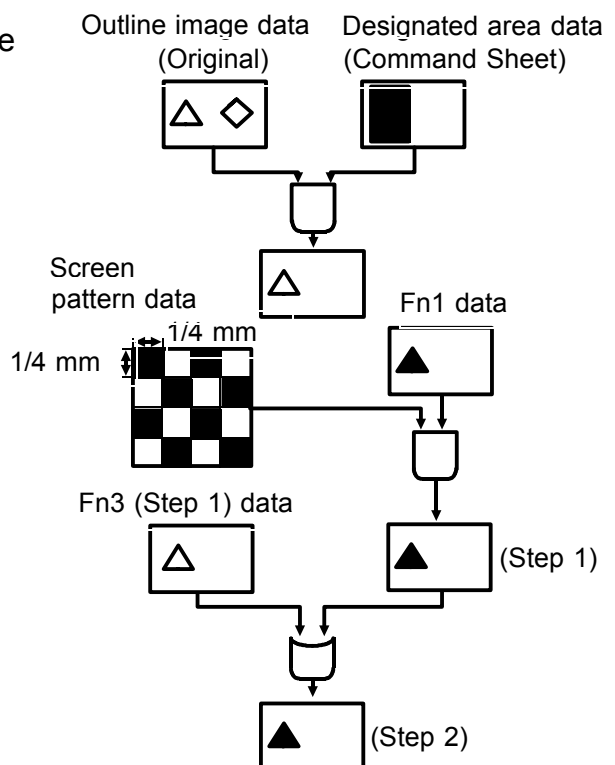

**Fn11, Fn21: Pattern Area / Outline Image**  
 (Fn51, Fn62)  
**Fn14, Fn24: Save Area / Pattern Area /**  
 (Fn54, Fn64)Outline Image

**Step 1:**  
 The background pattern data is ANDed with the designated area data and the edited image data is output.

**Step 2:**  
 The inverted image data is ANDed with the step 1 data and the edited image data is output.

**Step 3:**  
 The step 2 data is ORed with the Fn6 data and the edited image data is output.

**Step 4:**  
 The Fn2 data is ORed with the step 3 data and the edited image data is output.

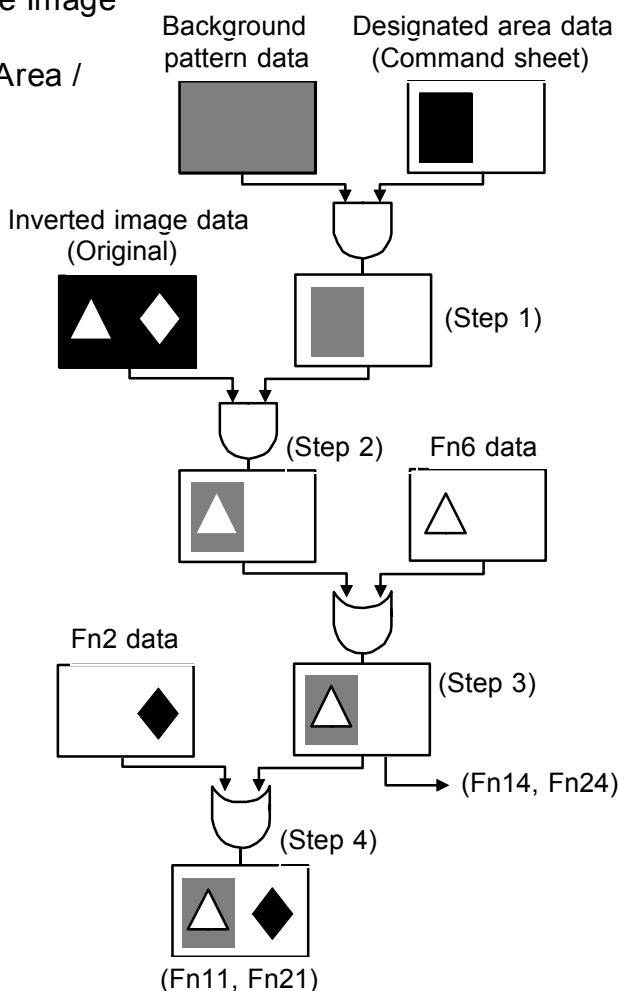

**Fn 12, Fn22: Pattern Area / Normal**  
 (Fn52, Fn62)Image  
**Fn 15, Fn25: Save Area / Pattern Area /**  
 (Fn55, Fn65)Normal Image

**Step 1:**  
 The background pattern data is ORed with the Fn1 data and the edited image data is output.

**Step 2:**  
 The Fn2 data is ORed with the step 1 data and the edited image data is output.

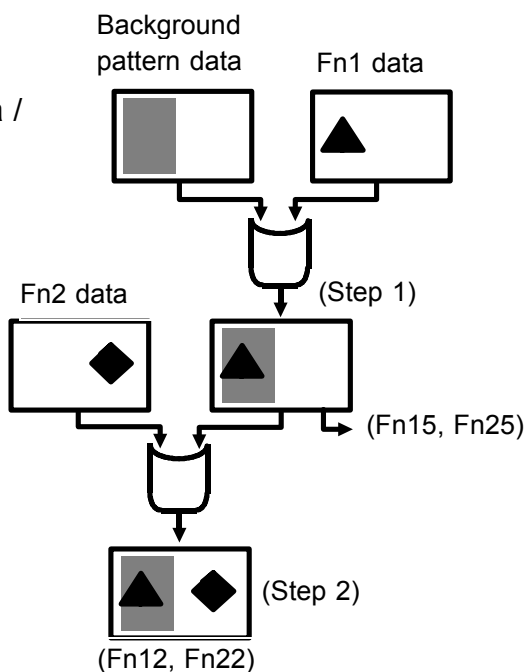

Fn13, Fn23 : Pattern Image

(Fn53, Fn63)

Fn16, Fn26 : Save Area / Pattern Image

(Fn56, Fn66)

Step 1:

The image data is ANDed with the designated area pattern data and the edited image data is output.

Step 2:

The Fn6 data is ORed with the step 1 data and the edited image data is output.

Step 3:

The step 2 data is ORed with the Fn2 data and the edited image data is output.

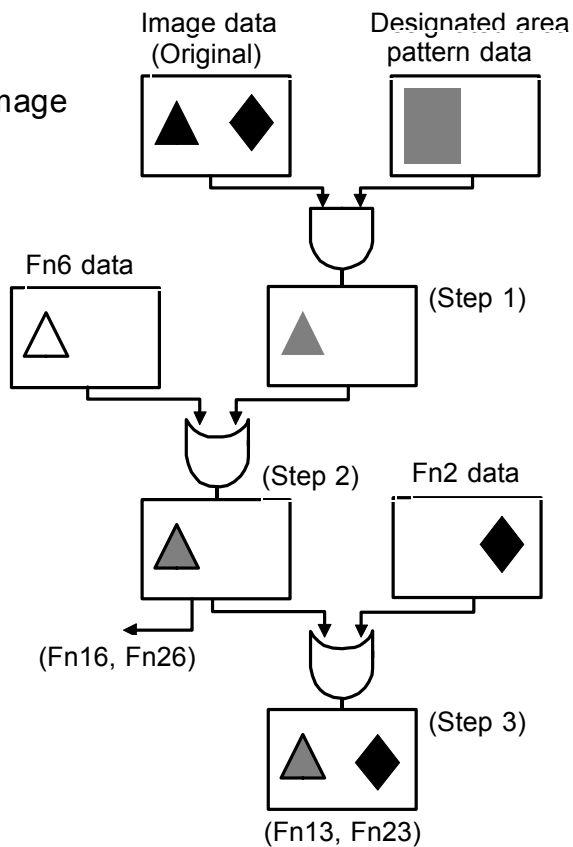

## 2.11.5 Background Pattern

### 1). 4 mm Background Pattern

The 2mm background pattern data is stored in the ROM on the make-up board.

The 4 mm background pattern is made by simply doubling the 2 mm background data with the F/F circuit.

Background data in ROM  
(2 mm standard pattern)

4 mm Background Pattern

Paper  
Feed  
Direction

→| ← 2/16

→| ← 2/16

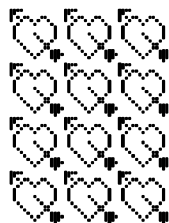
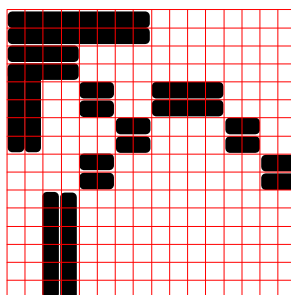
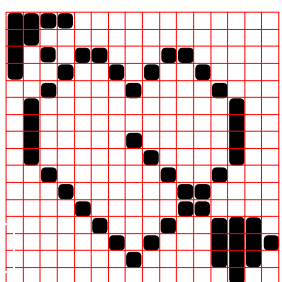

### 2). 90° Pattern Rotation

The 90° 2 mm background pattern data is also stored in the ROM on the make-up board.

The 90° 4 mm background pattern is made by doubling the 90° 2 mm background pattern data that has been rotated 90°.

Background data in ROM  
(2 mm standard pattern)

90° rotated background data in ROM  
(90° 2mm rotated pat-

Paper  
Feed  
Direction

→| ← 2/16

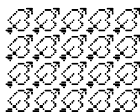
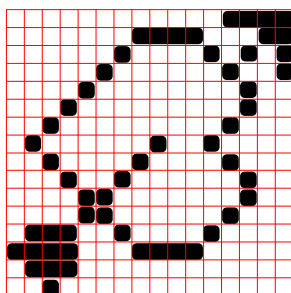
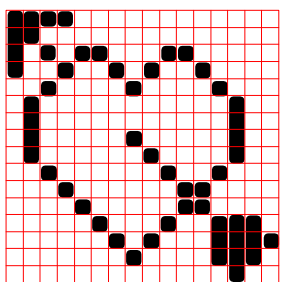

## 3). Background Patterns

The 40 background patterns shown below can be selected.

1

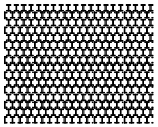
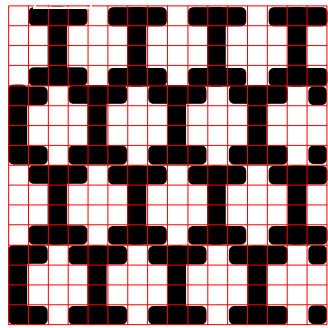

2

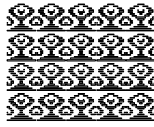
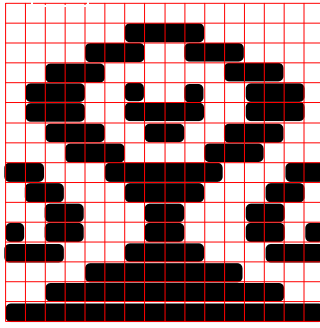

3

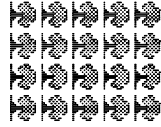
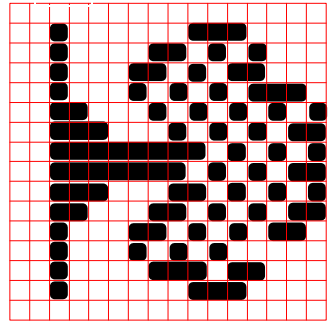

4

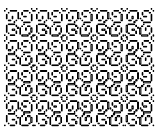
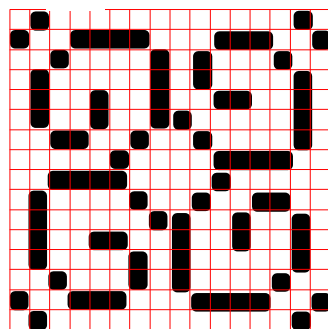

5

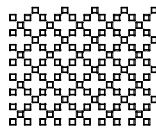
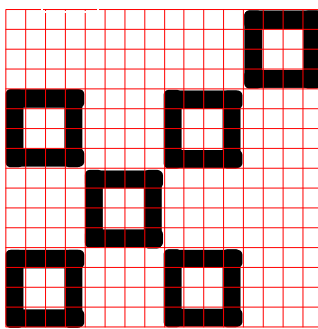

6

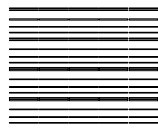
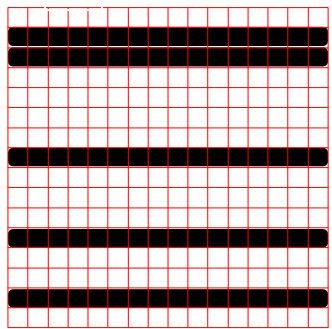

7

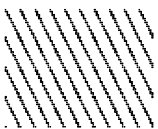
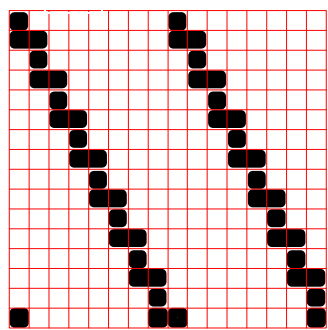

8

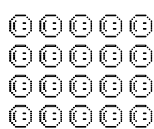
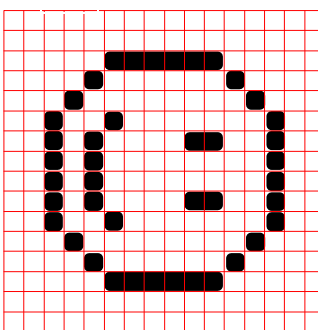

9

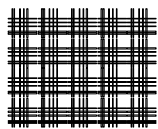
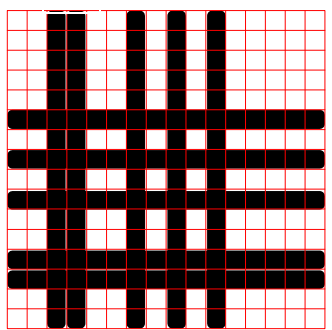



10

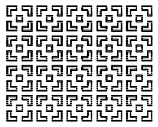
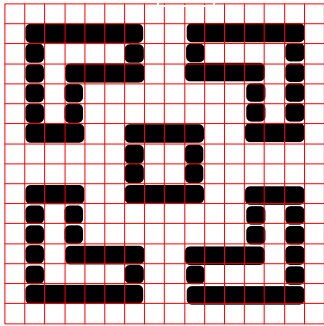

11

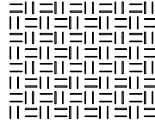
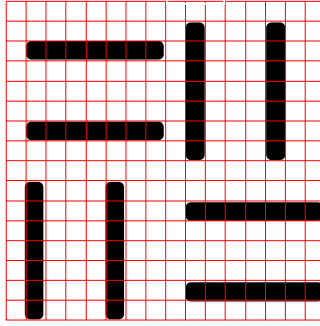

12

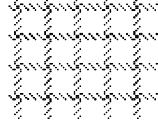
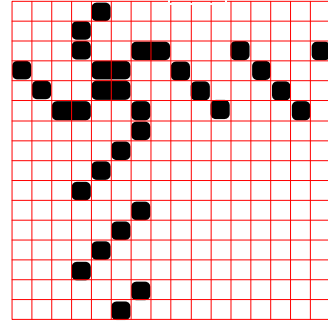

13

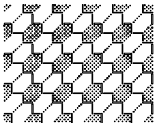
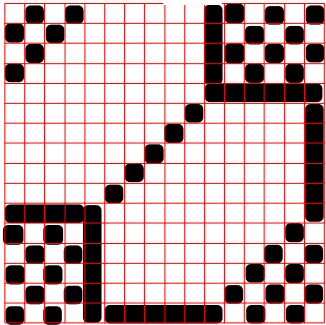

14

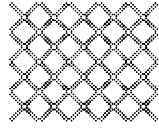
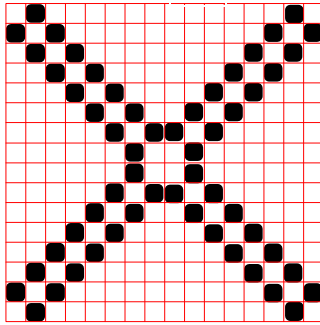

15

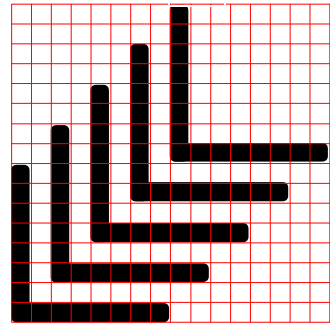

16

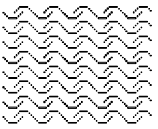
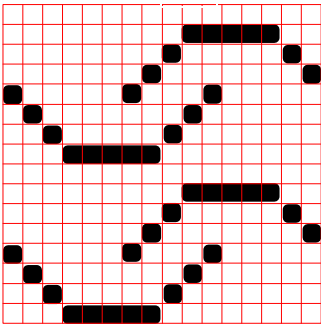

17

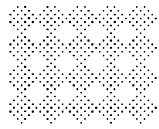
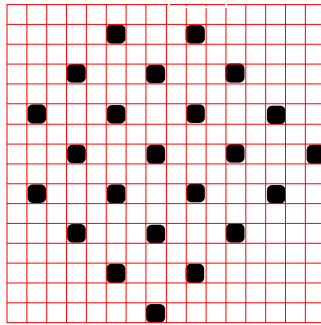

18

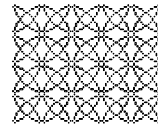
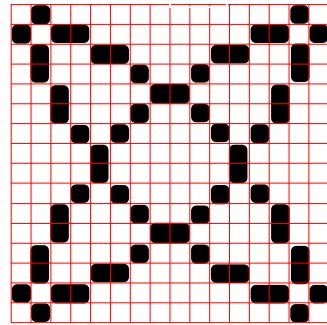

19

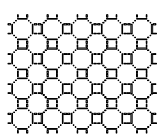
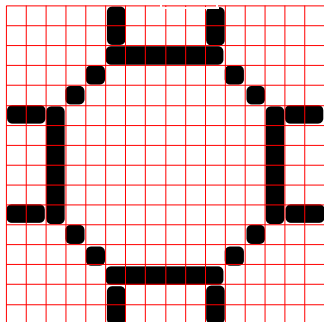

20

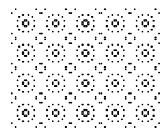
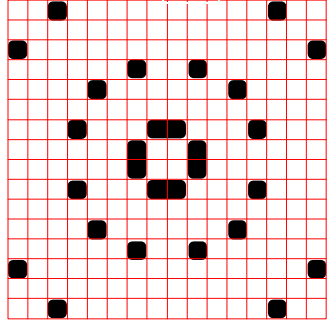

21

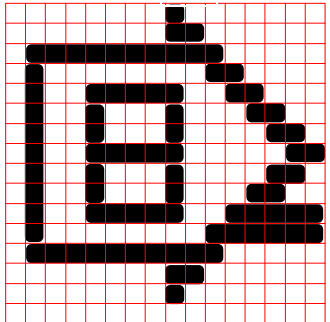

22

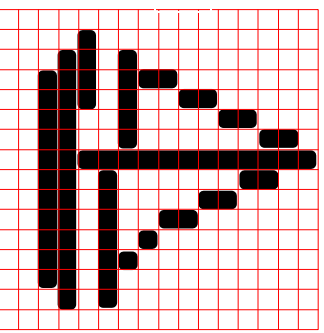

23

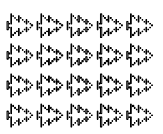
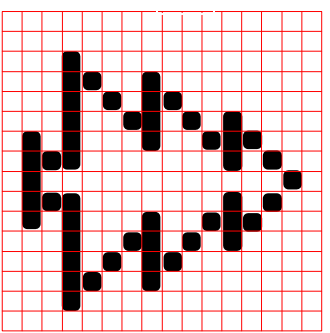

24

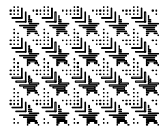
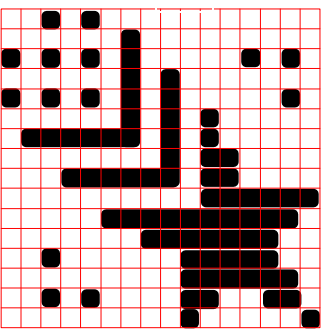

25

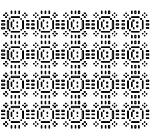
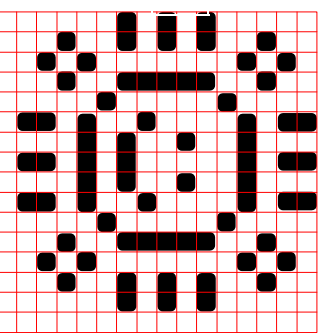

26

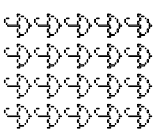
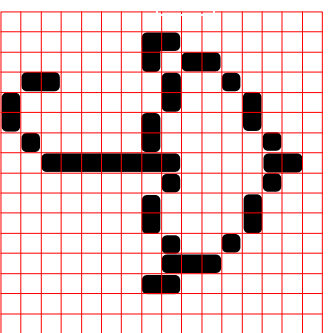

27

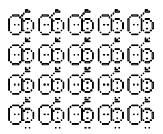
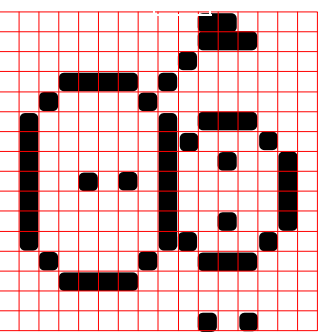

28

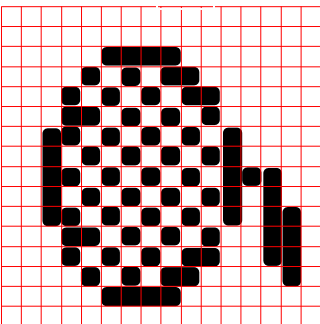

29

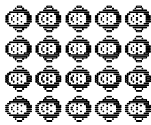
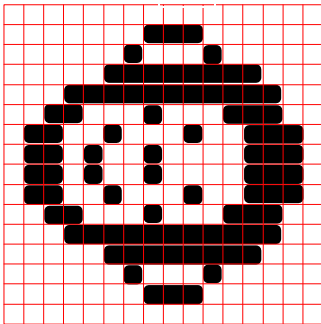

30

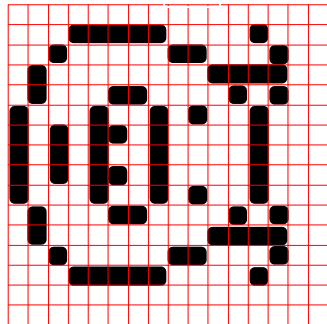

31

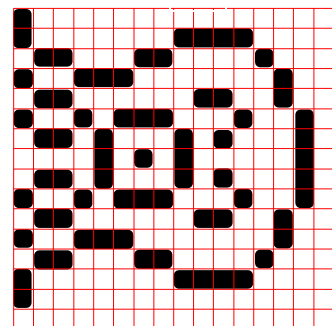

32

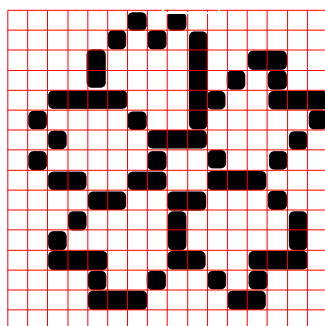

33

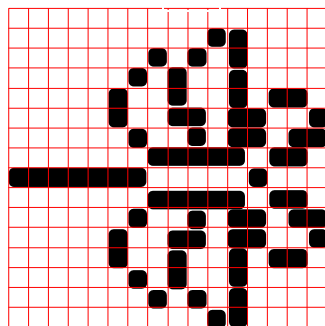

34

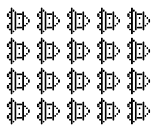
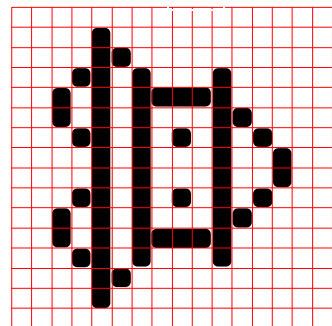

35

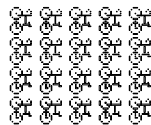
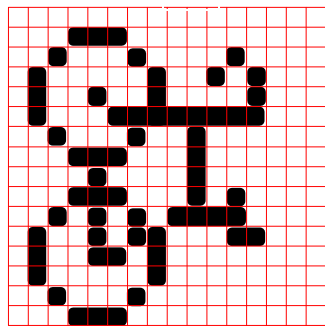

36

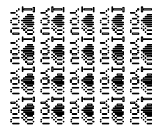
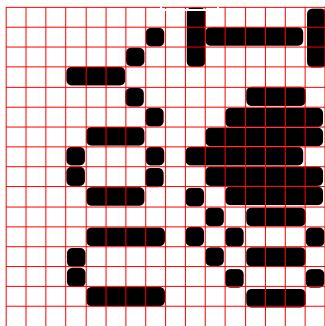

37

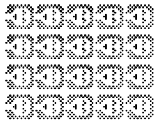
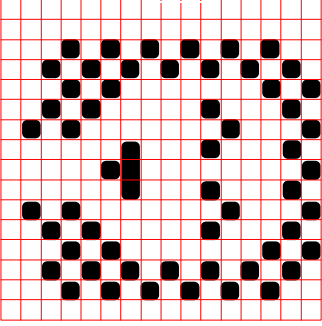

38

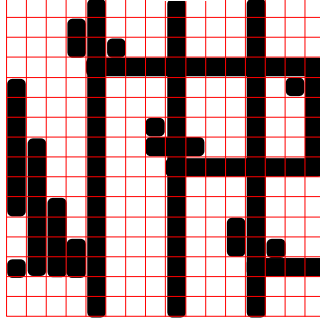

39

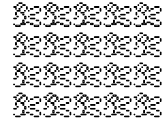
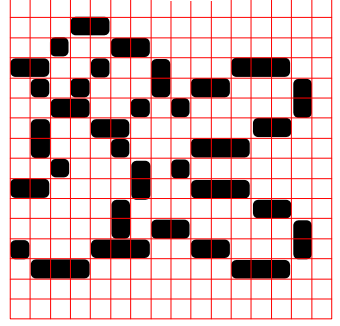

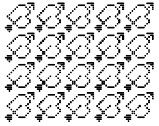
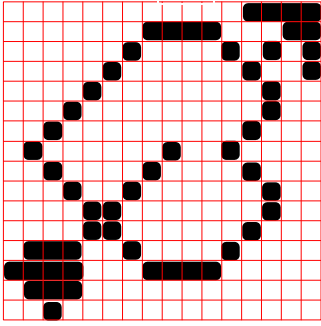

40

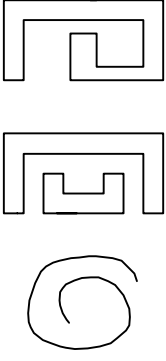
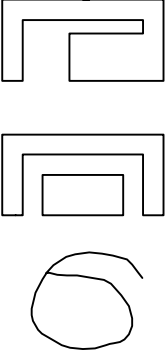
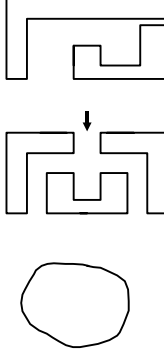
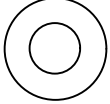
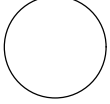

## 2.11.6 Recognition of Designated Area: VT2500 only

As the required image may differ depending on how the designated area is entered, make the command sheet by referring to the following.

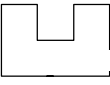
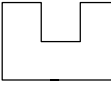
No.	Item	Sample of Problem		Preferred designated area
		Designated area	Area recognized	
1	Form of the designated area	Serial pattern	The designated area is recognized as follows:	Separation the area to be designated as follows:
				 <p>Make a space more than 2 mm.</p> <p>Make a space more than 2 mm.</p> <p>Designate area by a closed line.</p>
		Double circle pattern.	Only the outer circle will be recognized as follows:	Make a gap in the pattern.
				
2	Non-closed line	The designated area is not a closed loop.	The designated area is not recognized.	Designate the area by a closed loop.
				

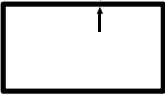
No.	Item	Sample of Problem		Preferred designated area
		Designated area	Area recognized	
3	Thickness of the designating line.	<p>The thickness of the line as follows:</p> <p>X = Full Size: less than 0.5 mm Reduction: less than 0.7 mm</p> <p style="text-align: center;">X ↓ </p>	As the line of the designated area is too thin, no designated area is recognized.	Mark with a line more than 1 mm in width.
4	Density of the designated line.	When using a pencil with low reflectivity or a color pen.	As the designating line is too light, no designated area is recognized.	Mark using a black pen.
5	Type of command sheet.	<p>1) Rough paper is used as a command sheet.</p> <p>2) If the command sheet has a different friction coefficient from the original.</p>	<p>Any fibrous black spots will be read as a designated area.</p> <p>Due to different registration of the original and the command sheet, the designated areas vary.</p>	<p>Use white paper (65 g/m<sup>2</sup>).</p> <p>Use white paper (65 g/m<sup>2</sup>).</p>

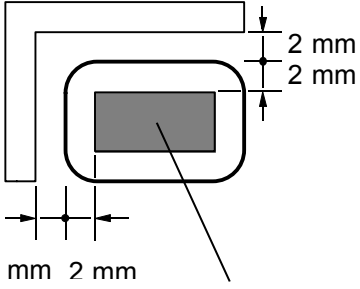
No.	Item	Sample of Problem		Preferred designated area
		Designated area	Area recognized	
6	Gap between the designated area and neighboring image. (Gap between two designated areas.)	When the gap between the designated area and neighboring image is too small.	Depending on the original feed condition (registration and skewing) or handwriting ability the designated area, the neighboring image may or may not be recognized as a designated area.	 <p>2 mm 2 mm 2 mm 2 mm (Image in the designated area)</p> <p>1) There should be more than 2 mm clearance between designated areas.</p> <p>2) Mark the line away from the image in the designated area move than 2 mm to recognized the image completely.</p> <p>3) For consideration of the handwriting ability, approximately 5 mm is needed as a gap.</p>

### 3. MASTER FEED SECTION

---

#### 3.1 OVERALL

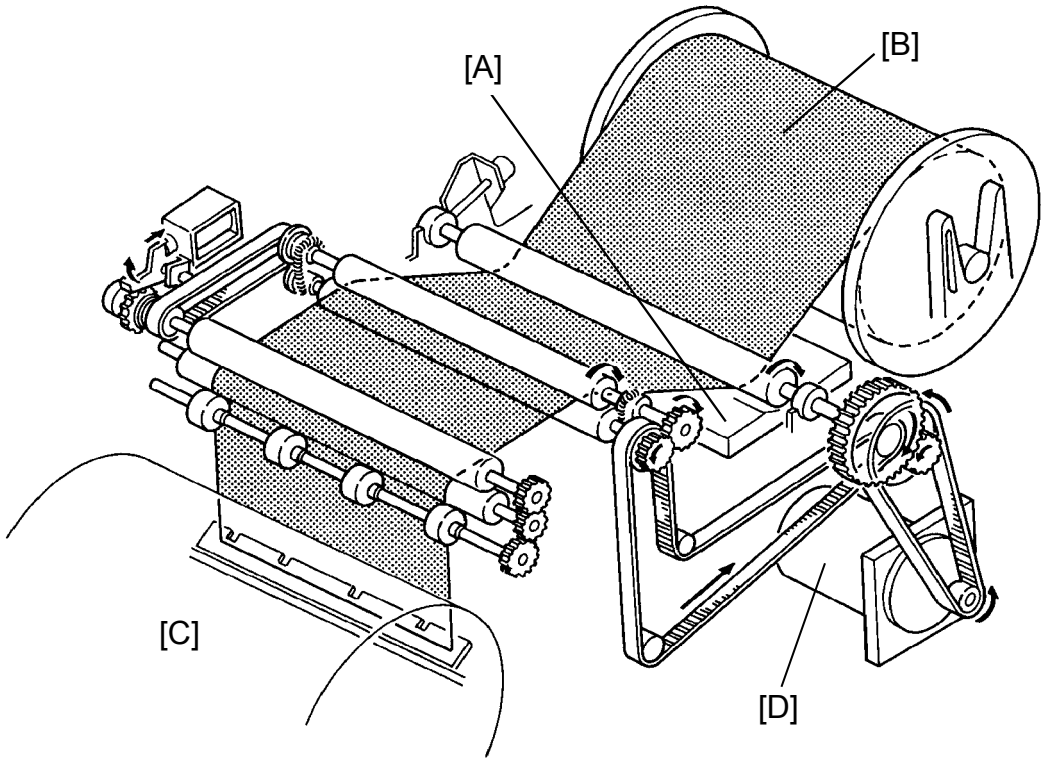

The thermal head [A] burns an image on the master [B] as it is being fed to the drum [C]. After this, the master is clamped and wrapped around the drum.



### 3.2 MASTER CLAMPER OPENING MECHANISM

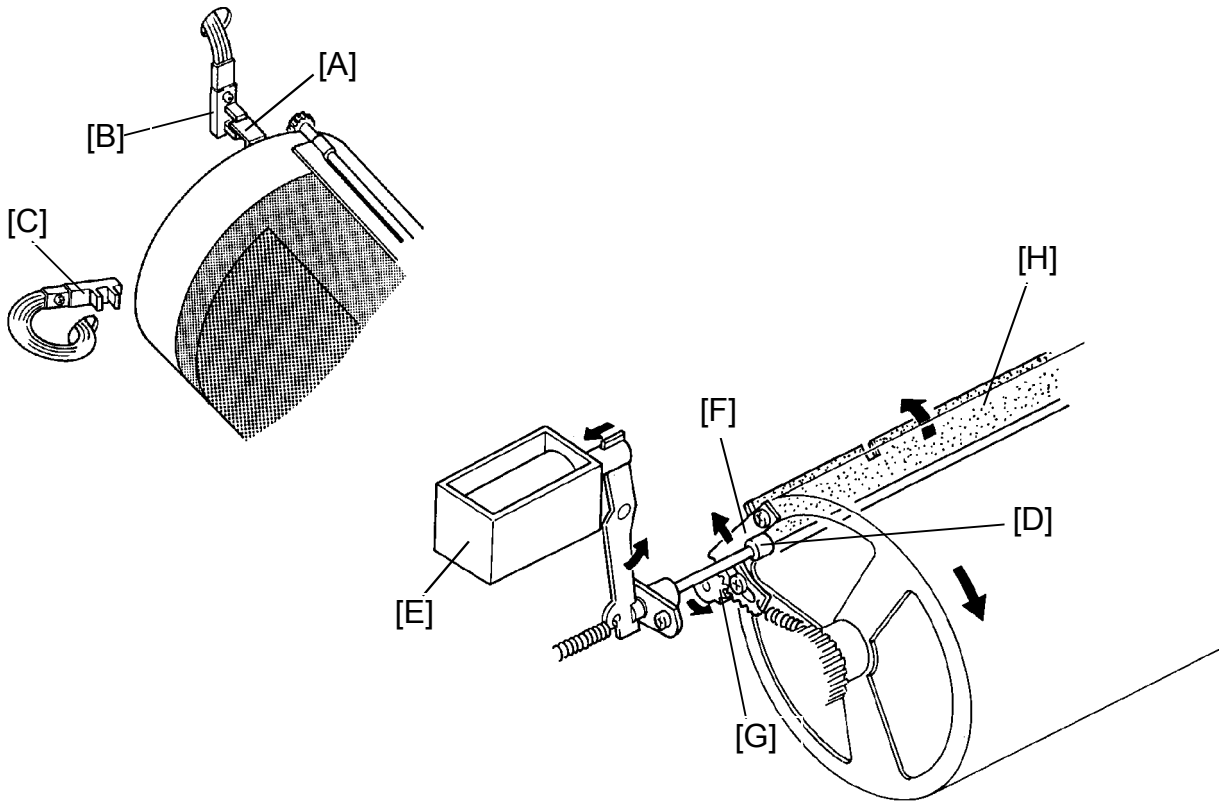

After the master eject process is finished and the interrupter [A] is positioned in the first drum position sensor [B], the main motor turns on and the drum starts rotating (30 rpm) in the reverse direction.

When the drum turns 160 degrees past the actuation position of the second drum position sensor [C], the cam [D] is moved to the drum's side as the master feed clamper solenoid [E] turns on.

When the drum turns 220 degrees further in the reverse direction, the sector gear [F] runs along the cam [D] and the gear [G] turns counterclockwise to open the clamper [H]. At the same time, the drum stops and the clamper remains open to clamp the master leading edge.



### 3.4 MASTER WRAPPING MECHANISM

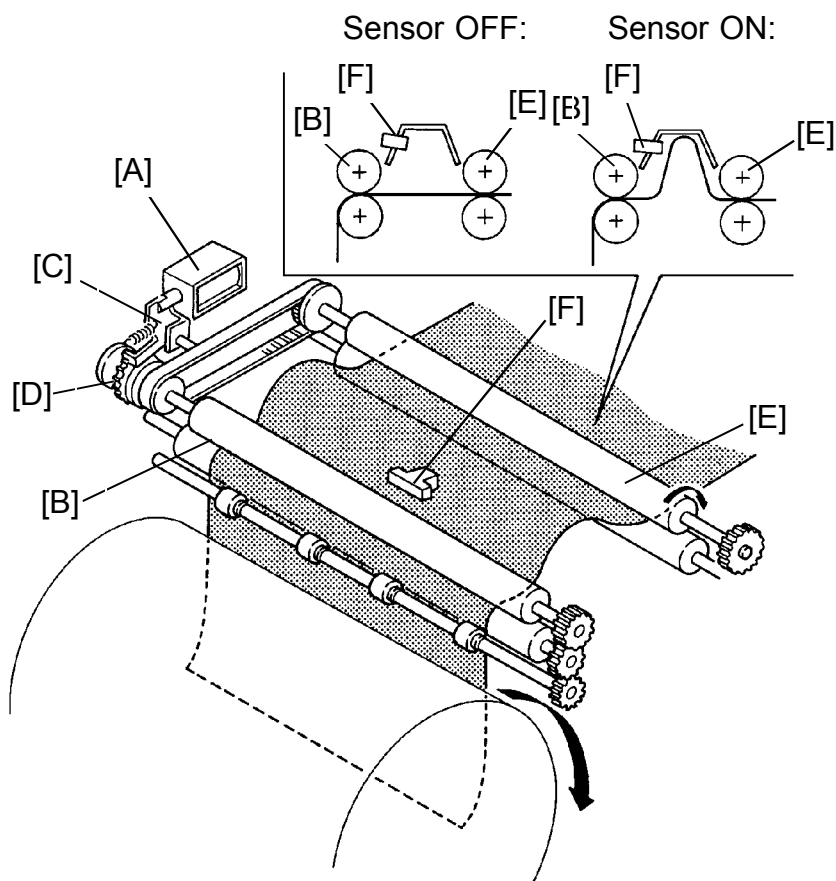

When the reverse roller solenoid [A] is turned off, the reverse roller [B] stops as the stopper [C] locks the clutch gear [D].

However, since the feed roller [E] turn continuously, the master continues to be fed causing the master to buckle. This buckle is detected by the master buckle sensor [F]. When the sensor turns on, the main motor turns on at 10 rpm to rotate the drum. The main motor turns off when the sensor turns off.

Therefore, the master is fed by the ON/OFF action of the master buckle sensor.

### 3.5 CUTTER MECHANISM

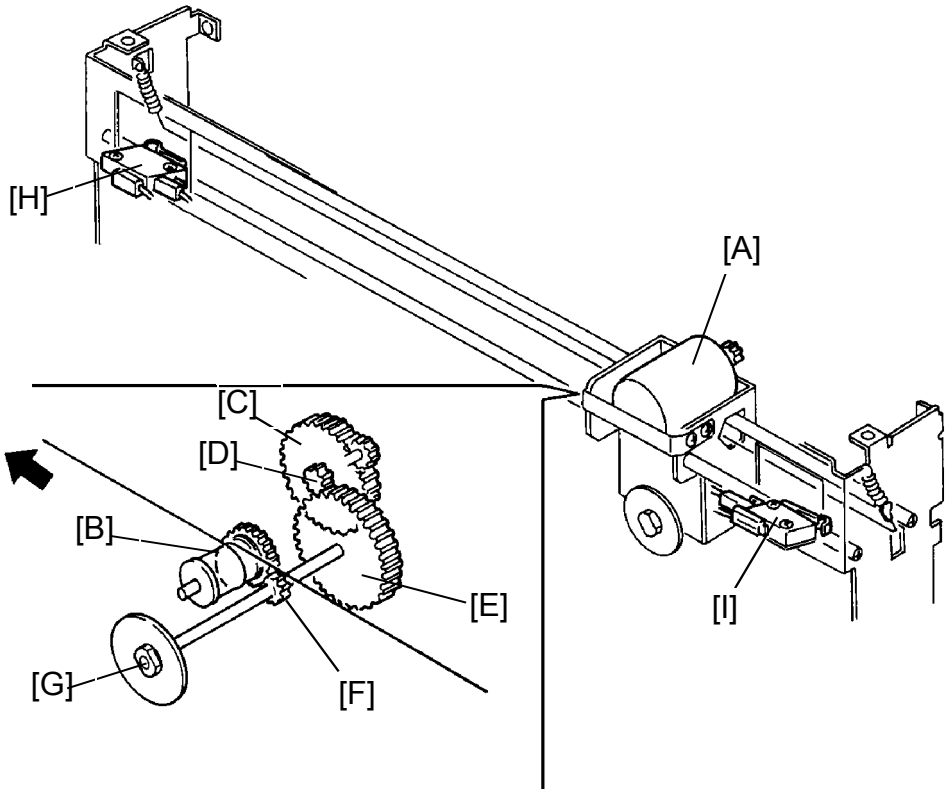

After the master making process (writing process) is finished, the master feed motor turns off and the cutter motor [A] starts turning in the reverse direction as indicated by the arrow.

The cutter motor drives the wire pulley [B] through the gears [C], [D], [E], and [F]. This is to shift the cutter unit to the rear (non-operation side). As the cutter [G] rotates and travels to the rear, it cuts the master.

When the right cutter switch [H] turns on, the cutter motor starts turning in the opposite direction to return the cutter unit to the front (operation side). When the left cutter switch [I] turns on, the cutter motor stops. This finishes the master cutting process.

After the master cutting process is finished, the master is fed about 42 millimeters.

### 3.6 ELECTRICAL TIMING

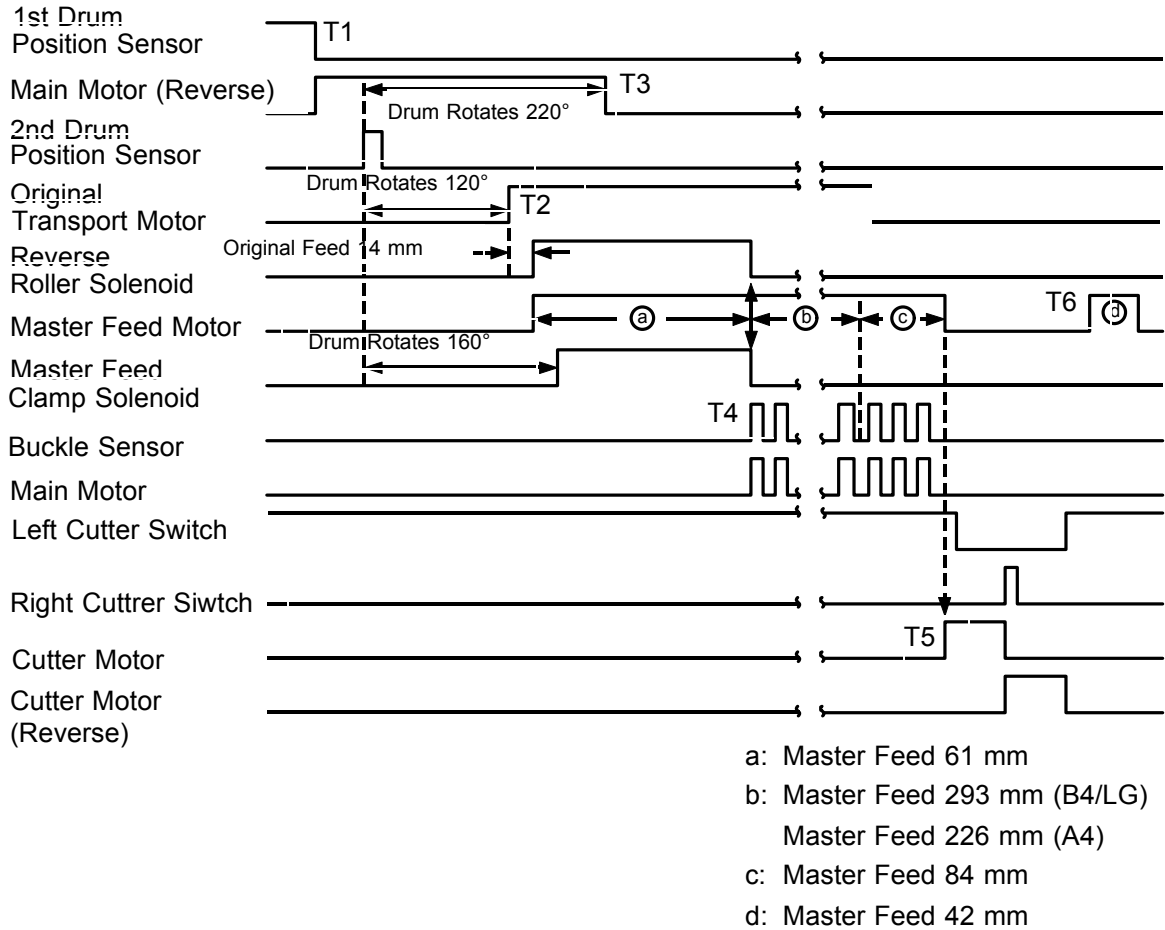

- T1: The main motor starts rotating in the reverse direction at 30 rpm after the master eject process is completed.
- T2: After the drum rotates 120 degrees past the point where the 2nd drum position sensor is activated, the original transport motor turns on and starts feeding the original. The master feed motor turns on and the reverse roller solenoid energizes when the original has fed 14 mm.
- T3: The main motor stops and the clamber remains open when the drum rotates 220 degrees past the point where the 2nd drum position sensor is activated.

- T4: The reverse roller solenoid and the master feed clamper solenoid are de-energized when the master is fed 61 mm.  
After the reverse roller solenoid is de-energized, the master buckles and the master buckle sensor is activated. At the same time the main motor turns on to wrap the master around the drum. When the master is fed to the drum, the master buckle sensor is de-activated, and the main motor stops. The master continues to feed by repeating the above steps, controlled by the ON/OFF action of the buckle sensor.
- T5: The main motor stops after the master paper is fed 438 mm for B4/LG (371 mm for A4.) At the same time the cutter motor rotates to cut the master paper.
- T6: When the cutter returns to the home position, the master feed motor rotates again to feed the master paper 42 mm.

## 3.7 CIRCUIT: VT2300/VT2500

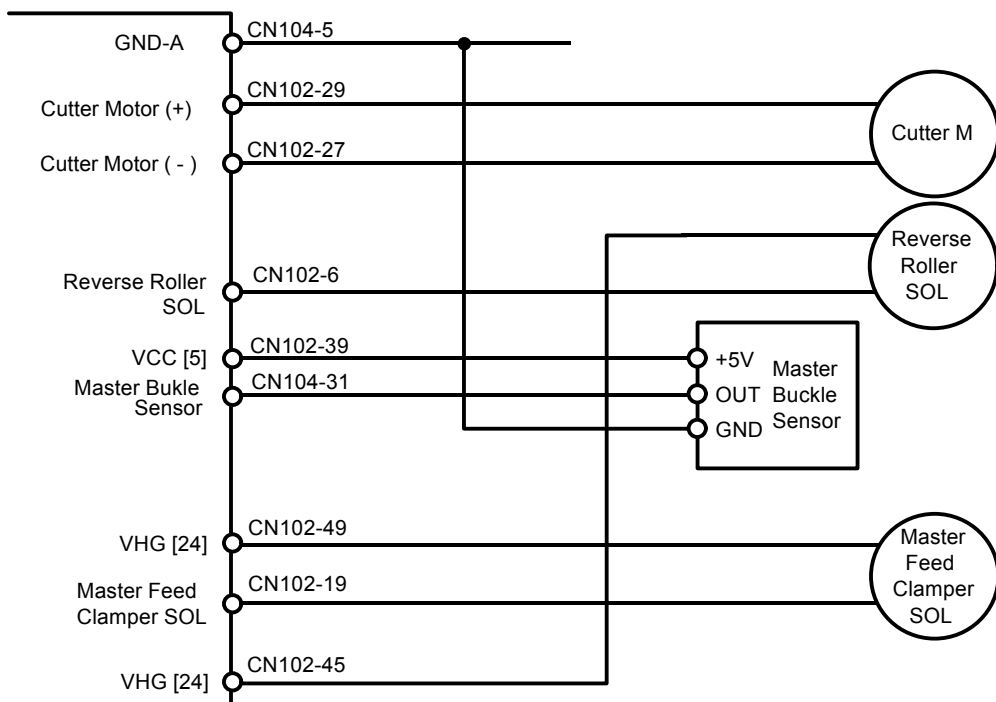

## 3.8 INPUT/OUTPUT: VT2300/VT2500

Signal Name	I/O	Main Control PCB		Description
		CN No.	Level	
Master Buckle Sensor	I	CN104-31	0V $\rightarrow$ 5V	When the sensor is activated, CN104-31 becomes 5V.
Reverse Roller Solenoid	O	CN102-6	24V $\rightarrow$ 0V	When the solenoid is turned on, CN102-6 becomes 0V.
Master Feed Clamper Sol.	O	CN102-19	24V $\rightarrow$ 0V	When the solenoid is turned on, CN102-19 becomes 0V.
Cutter Motor (+)	O	CN102-29	22V $\rightarrow$ 0V	When the cutter unit is returning, CN102-29 becomes 0V
Cutter Motor (-)	O	CN102-27	22V $\rightarrow$ 0V	When the cutter unit is moving to the non operation side, CN102-27 becomes 0V.

## Master Eject Motor

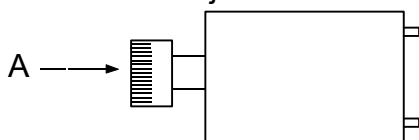

The specified direction of the motor rotation is as viewed from A.

## 3.9 CIRCUIT: VT2100/VT2130/VT2150

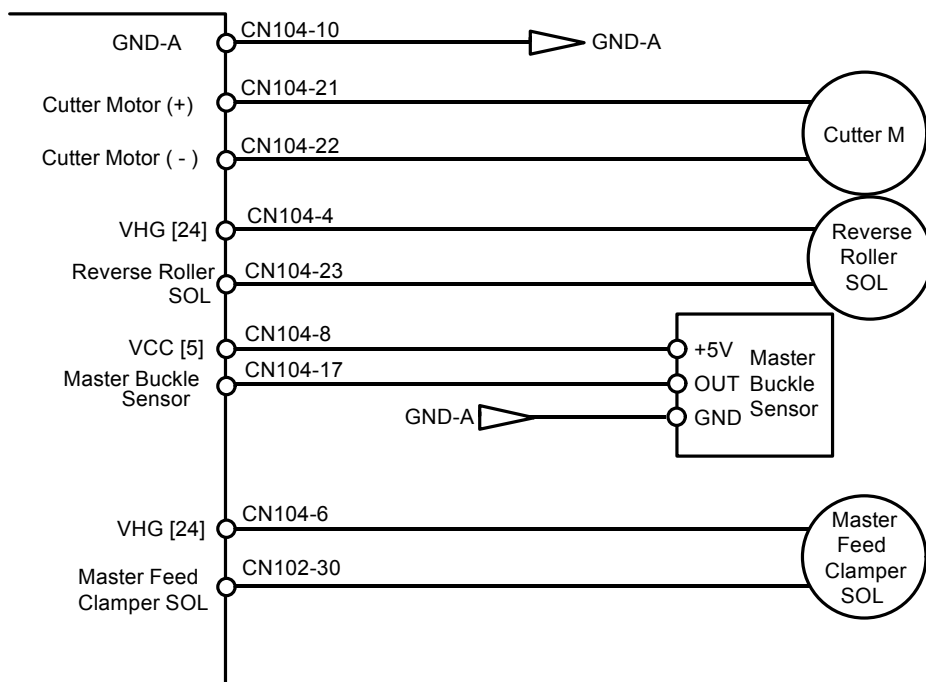

## 3.10 INPUT/OUTPUT: VT2100/VT2130/VT2150

Signal Name	I/O	Main Control PCB		Description
		CN No.	Level	
Master Buckle Sensor	I	CN104-17	0V $\rightarrow$ 5V	When the sensor is activated, CN104-17 becomes 5V.
Reverse Roller Solenoid	O	CN104-23	24V $\rightarrow$ 0V	When the solenoid is turned on, CN104-23 becomes 0V.
Master Feed Clamper Sol.	O	CN102-30	24V $\rightarrow$ 0V	When the solenoid is turned on, CN102-30 becomes 0V.
Cutter Motor (+)	O	CN104-21	22V $\rightarrow$ 0V	When the cutter unit is returning, CN104-21 becomes 0V.
Cutter Motor (-)	O	CN104-22	22V $\rightarrow$ 0V	When the cutter unit is moving to the non operation side, CN104-22 becomes 0V.

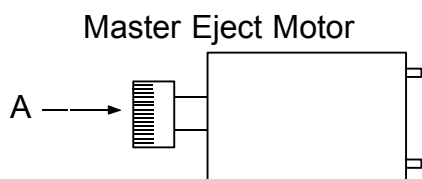

The specified direction of the motor rotation is as viewed from A.





## 4. MASTER EJECT SECTION

### 4.1 OVERALL

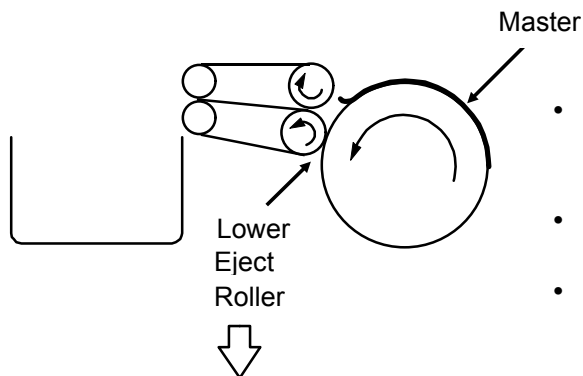

- Drum rotates in direction opposite to printing.
- Master eject rollers rotate.
- Lower eject roller contacts drum.

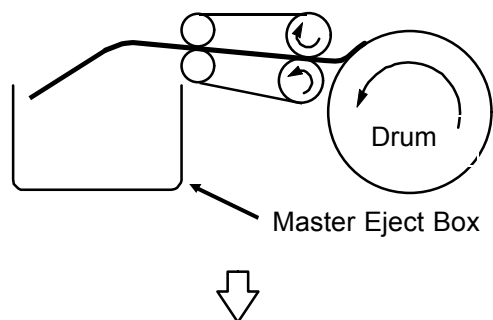

- The curled master is caught between the upper and lower eject rollers to eject the master into the master eject box.

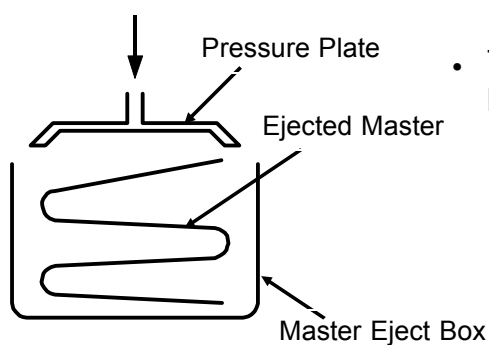

- The ejected master is compressed by the pressure plate.

To eject the master wrapped around the drum, the drum rotates in the direction opposite to the printing direction. Thus, the master is ejected into the master eject box by utilizing the back curl of the master trailing edge which is caught between the upper and lower eject rollers.

The ejected master is then compressed by the pressure plate to fully utilize the master box capacity.

## 4.2 MASTER EJECT ROLLER ROTATING MECHANISM

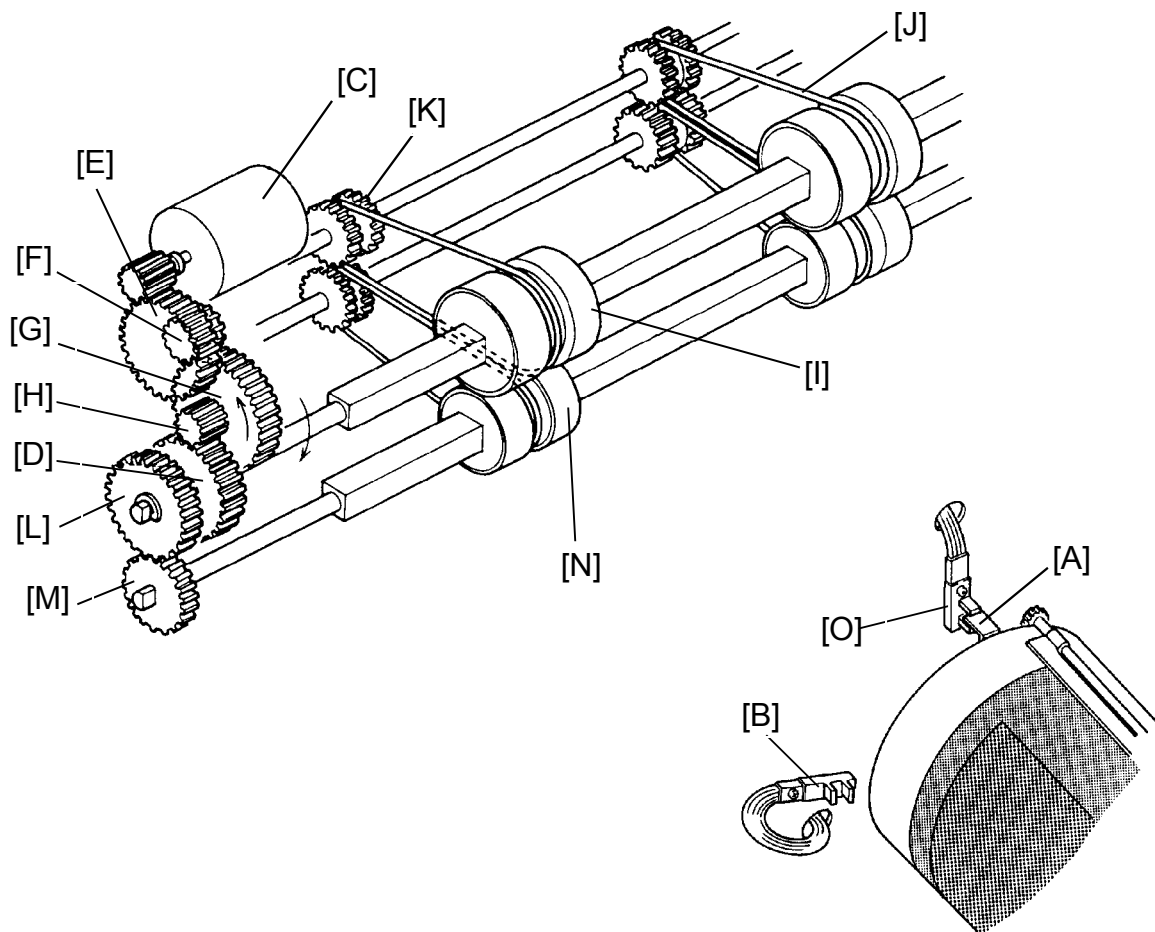

After the original is set, the main motor rotates in the reverse direction (30 rpm) when the Master Making key is pressed.

When the interrupter [A] blocks the 2nd drum position sensor [B], the master eject motor [C] starts rotating counterclockwise and the gear [D] is driven clockwise through gears [E], [F], [G], and [H]. The upper first eject rollers [I] also turn clockwise, because gear [D] has a one-way clutch. At the same time, the belts [J] drive the upper second eject rollers [K], and gears [L] and [M] drive the lower eject rollers [N] counterclockwise.

After the drum completes one rotation in the reverse direction, the interrupter [A] blocks the first drum position sensor [O]. The master eject roller then stops rotation.

NOTE: The VT2300/VT2500 use a timing belt instead of a gear [E]. (See page 2-84.)

### 4.3 MASTER EJECT ROLLER DRIVE MECHANISM

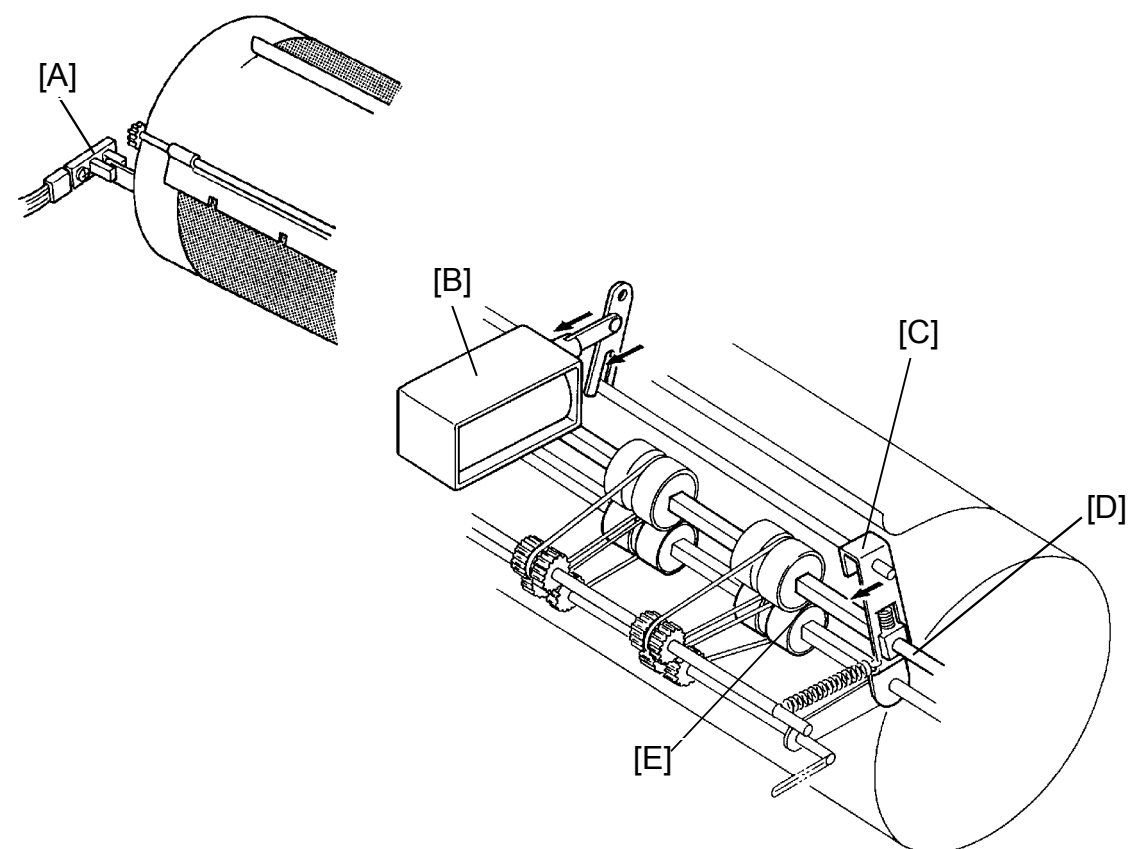

When the drum turns 20 degrees past the second drum position sensor [A], the master eject solenoid [B] turns on and the supporter [C] turns counter-clockwise around the upper eject roller shaft [D]. This forces the lower first eject rollers [E] to contact the drum.

As the drum turns, the curled trailing edge of the master enters between the upper and lower first eject rollers. The first eject rollers then peel the master from the drum.

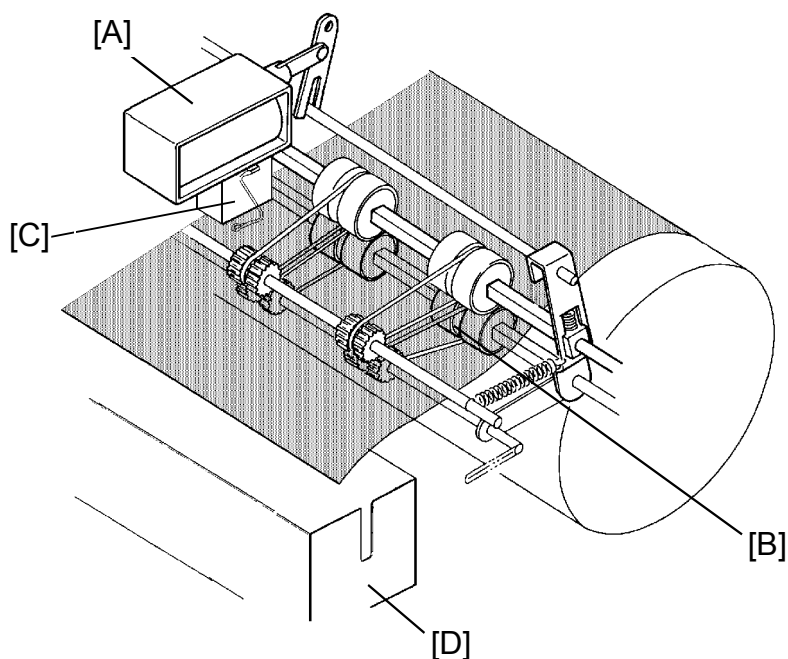

When the drum turns 70 degrees past the second drum position sensor, the master eject solenoid [A] turns off, separating the lower first eject roller [B] from the drum.

When the ejected master is between the upper and lower first eject rollers, it activates the master eject switch [C]. After that, the master is stacked into the master eject box [D].

**NOTE:** The VT2300/VT2500 use a photo reflective sensor instead of a mechanically actuated switch [C].

## Master Eject Misfeed Detection:

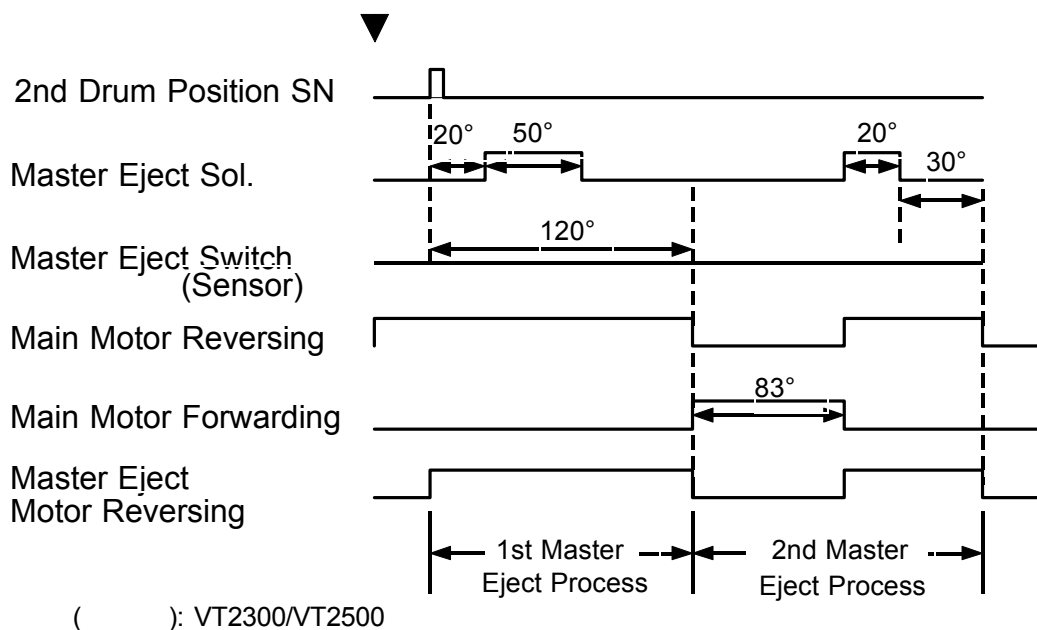

When the master eject switch is not activated within 120 degrees of drum reverse rotation during the 1st master eject process, the drum rotates 83 degrees in the forward direction to repeat the master eject process (2nd master eject process) as shown above.

If the master eject switch is not turned on again in the 2nd master eject process, a master eject misfeed is detected.

When a master misfeed occurs during the 2nd master ejection, rotation of the drum in the reverse direction stops, the master eject motor turns off, and the main motor turns on to drive the drum to the home position. After the drum returns to the home position, the beeper sounds, and F and  indicators blink.

NOTE: The VT2300/VT2500 use a photo reflective master eject sensor.

#### 4.4 MASTER EJECT CLAMPER MECHANISM

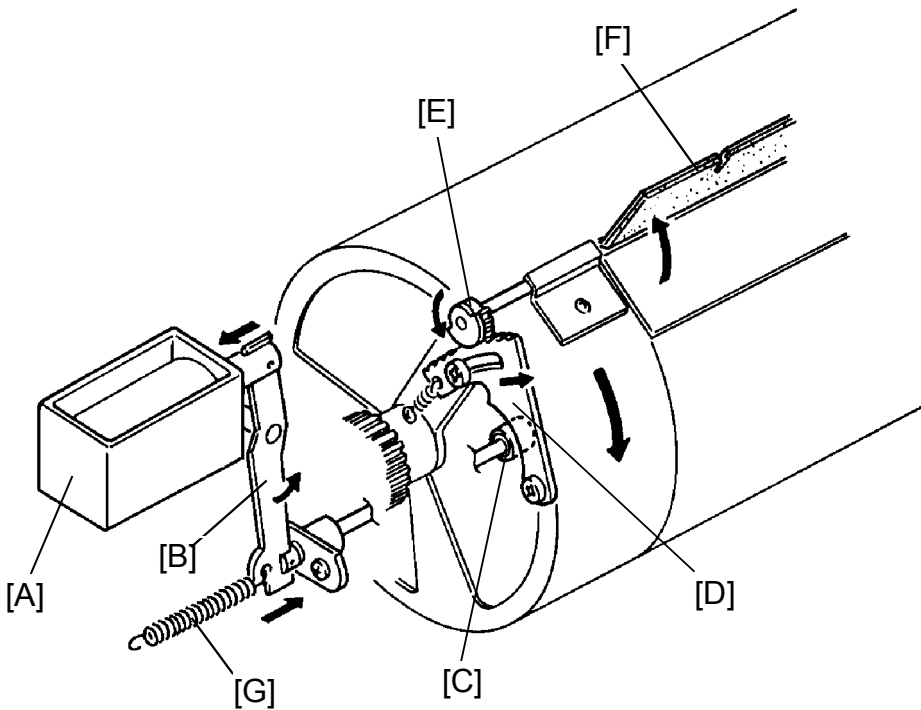

When the drum has turned 230 degrees past the second drum position sensor activation position, the master eject clamper solenoid [A] turns on and turns the lever [B] counterclockwise. This moves the cam [C] to the drum's side. After that, the clamper sector gear [D] rides on the cam [C] and the gear [E] turns counterclockwise opening the master clamper [F] for master ejection.

When the drum turns 13 degrees past the first drum position sensor, the main motor turns off. Then, after 0.5 second, the master eject clamper solenoid turns off and the spring [G] returns the opening cam to the normal position.

## 4.5 PRESSURE PLATE UP/DOWN MECHANISM

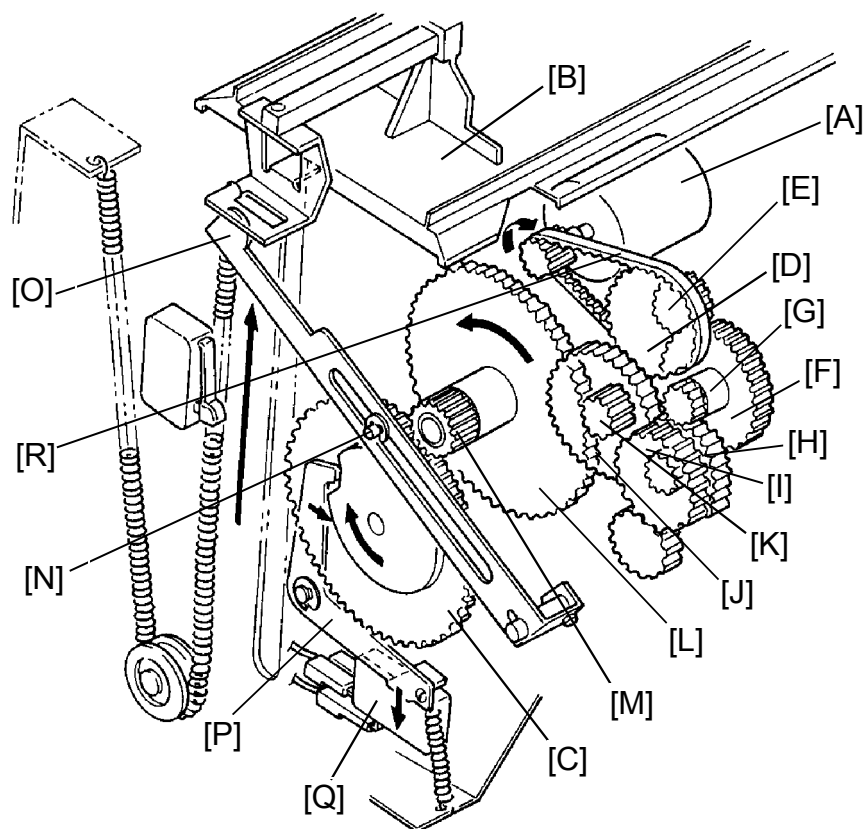

After the master making process is finished, the master eject motor [A] turns clockwise to raise the pressure plate [B].

When the master eject motor turns, the gear [C] is driven through the timing belt [R] the gears [D], [E], [F], [G], [H], [I], [J], [K], [L] and [M]. The pin [N] on the gear [C] which is inserted into the link [O] rises and lifts the left end of the link; thus, raising the pressure plate [B].

The gear [C] continues to turn until the lever [P] moves into the notch on the bottom of the cam, located behind the gear [C]. At this time, the master eject motor [A] stops as the lower end of the lever [P] pushes the pressure plate position switch [Q]. Thus, the pressure plate is held in the upper position.

When the master eject motor turns clockwise, the gear [I] turns clockwise, but the upper first eject roller does not turn because of a one-way clutch in the gear [I]. Also, when the master eject motor turns in the reverse direction (counterclockwise), the pressure plate does not move because of a one-way clutch in the gear [L].

NOTE: The VT2100/VT2130/VT2150 use a gear instead of a timing belt [R]. (See page 2-79.)

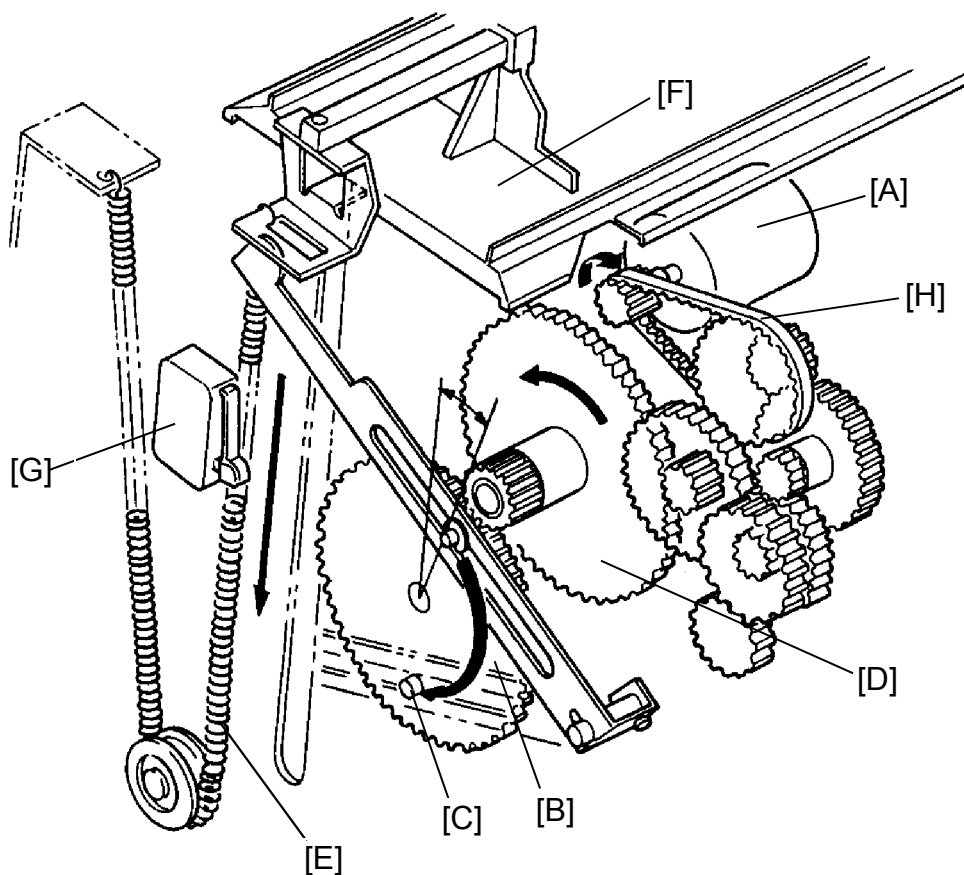

After the master eject process is finished, the master eject motor [A] turns clockwise, driving the gear [B] clockwise through the relay gears.

When the pin [C] of the gear [B] turns about 45 degrees, the pressure plate goes down immediately due to the one-way clutch in the gear [D] and the pressure spring [E]. Therefore, the ejected master in the master eject box is compressed by the pressure plate [F].

If the full master detecting switch [G] does not turn on when the pressure plate goes down, this means that the master eject box is filled with ejected masters. In this case, the "F" and  indicators blink, and the machine stops after a new master is wrapped.

The "F" and  indicators cannot be reset until the master box switch is turned OFF and ON. This is to prevent the full ejected master condition from being reset without removing the ejected master from the box.

NOTE: The VT2100/VT2130/VT2150 use a gear instead of a timing belt [H]. (See page 2-79.)



## 4.6 ELECTRICAL TIMING

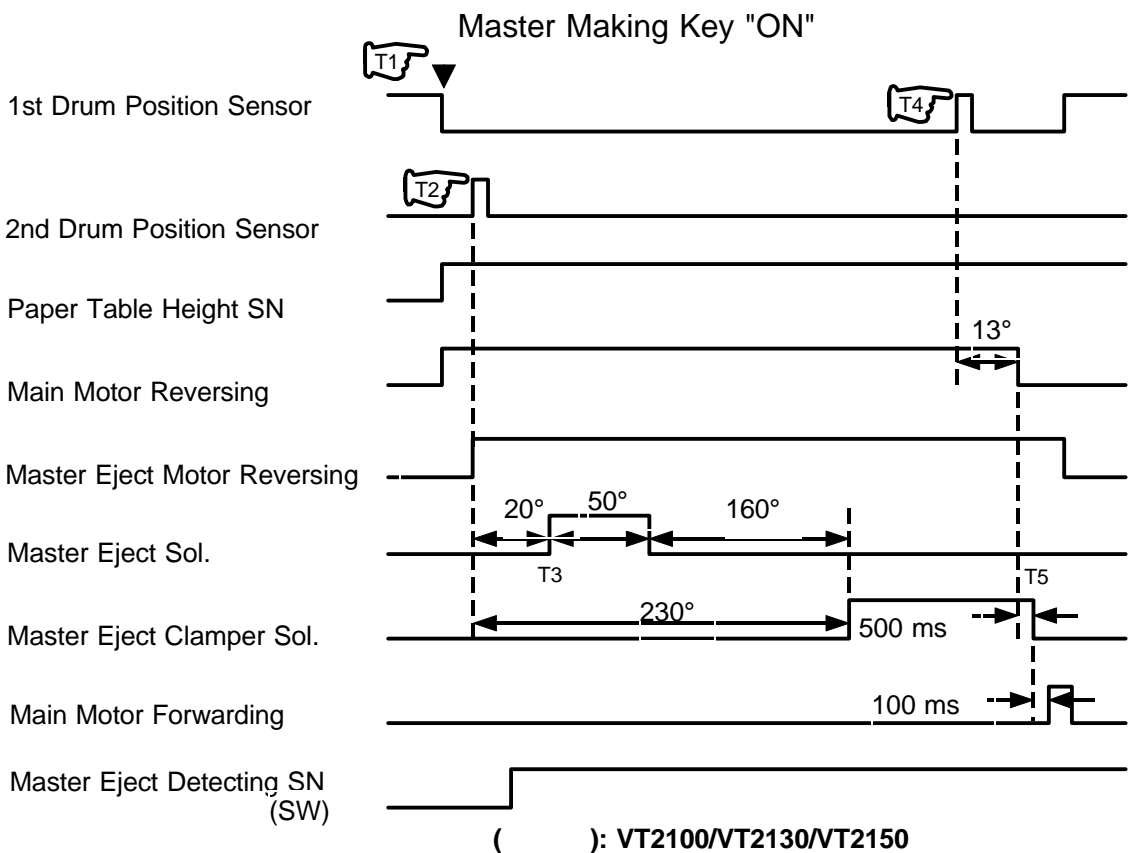

- T1: When the Master Making key is pressed, the main motor starts rotating in reverse. At the same time the paper table drive motor also starts rotating to lift the paper table to the proper position.
- T2: When the 2nd drum position sensor is activated, the master eject motor starts rotating in reverse to drive the master eject rollers.
- T3: When the drum rotates 20 degrees past the 2nd drum position sensor, the master eject solenoid is energized to press the master eject roller against the drum surface. The master eject solenoid is de-energized when the drum rotates 50 degrees more. When the drum rotates 160 degrees after the master eject solenoid is de-energized the master eject clamper solenoid is energized.
- T4: When the drum turns 13 degrees past the first drum position sensor actuation position, the main motor stops.
- T5: 500 milliseconds after the main motor stops, the master eject clamper solenoid turns off. Then, after a 100 millisecond-pause, the main motor starts rotation in the forward direction and stays on until the first drum position sensor is activated.

### 4.7 CIRCUIT: VT2300/VT2500

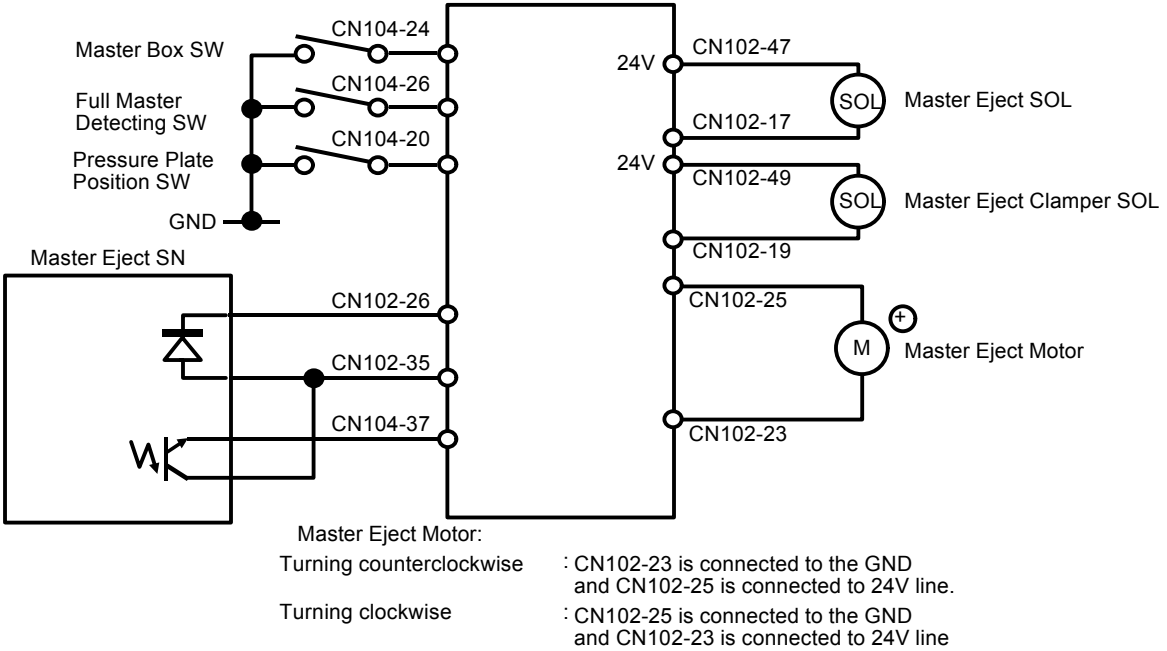

### 4.8 INPUT/OUTPUT: VT2300/VT2500

Signal Name	I/O	Main Control Board		Description
		CN No.	Level	
LED: Master Eject Detection	0	102-26		When the main switch is turned on, the voltage at CN102-26 is 0V.
Master Eject Detection	I	104-37		When the master is placed under the sensor, the voltage is 0.2V_0.4V at CN104-37 and 4V at TP104 (MDLV).
Master Box Detection	I	104-24		When the master box switch turns on, the voltage at CN104-24 is 0V.
Full Master Detection	I	104-26		When the full master detection switch turns on, the voltage at CN104-26 is 0V.
Pressure Plate Position	I	104-20		When the pressure plate position switch turns on, the voltage at CN104-20 is 0V.
Master Eject Solenoid	0	102-17		When the master eject solenoid turns on, the voltage at CN 102-17 is 0V.
Master Eject Clamper Solenoid	0	102-19		When the master eject clamper solenoid turns on, the voltage at CN102-19 is 0V.
+: Master Eject Motor	0	102-25		When the master eject motor turns clockwise, the voltage at CN102-25 is 22V.
-: Master Eject Motor	0	102-23		When the master eject motor turns counterclockwise, the voltage at CN102-23 is 22V.

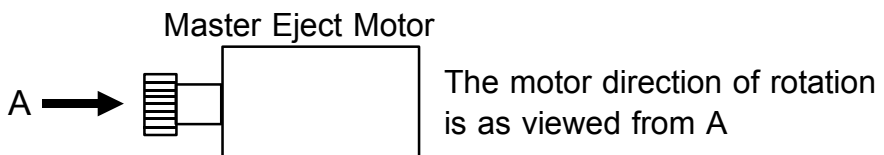

## 4.9 CIRCUIT: VT2100/VT2130/VT2150

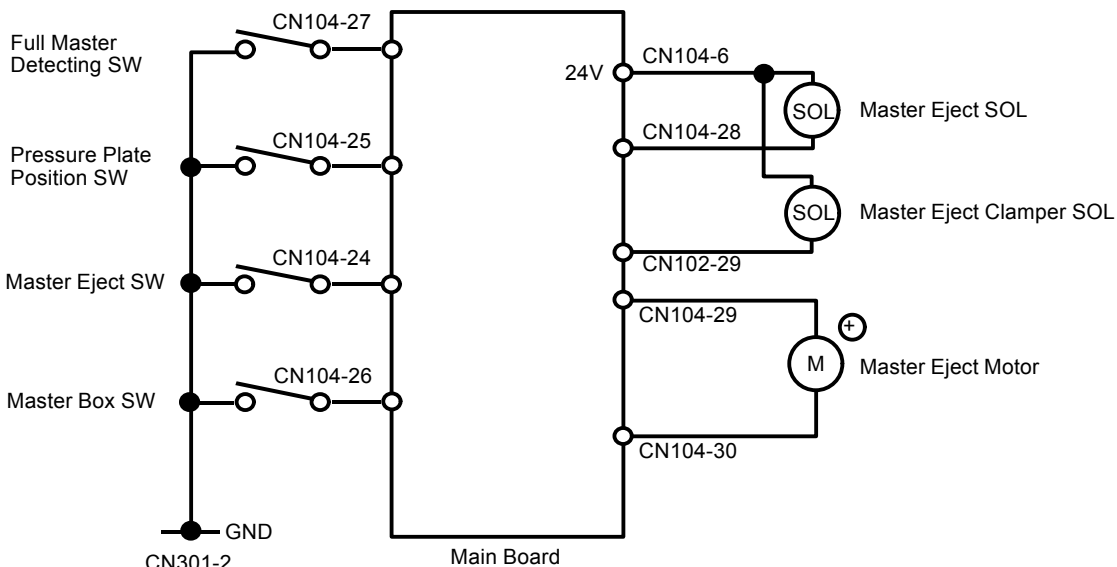

Master Eject Motor:  
 Turning counterclockwise : CN104-30 is connected to the GND and CN104-29 is connected to 24V line.  
 Turning clockwise : CN104-29 is connected to the GND and CN104-30 is connected to 24V line

## 4.10 INPUT/OUTPUT: VT2100/VT2130/VT2150

Signal Name	I/O	Main Control Board		Description
		CN No.	Level	
Master Eject Detection	I	104-24		When the master eject detection switch turns on, the voltage at CN104-24 is 0V
Master Box Detection	I	104-26		When the master box switch turns on, the voltage at CN104-26 is 0V
Full Master Detection	I	104-27		When the full master detection switch turns on, the voltage at CN104-27 is 0V
Pressure Plate Position	I	104-25		When the pressure plate position switch turns on, the voltage at CN104-25 is 0V
Master Eject Solenoid	O	104-28		When the master eject solenoid turns on, the voltage at CN104-28 is 0V
Master Eject clamper Solenoid	O	102-29		When the master eject clamper solenoid turns on, the voltage at CN102-29 is 0V
+: Master Eject Motor	O	104-29		When the master eject motor turns clockwise, the voltage at CN104-29 is 22V
-: Master Eject Motor	O	104-30		When the master eject motor turns counter clockwise, the voltage at CN104-30 is 22V

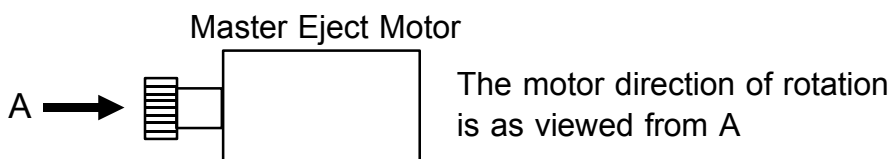

## 5. PAPER FEED SECTION

### 5.1 OVERALL

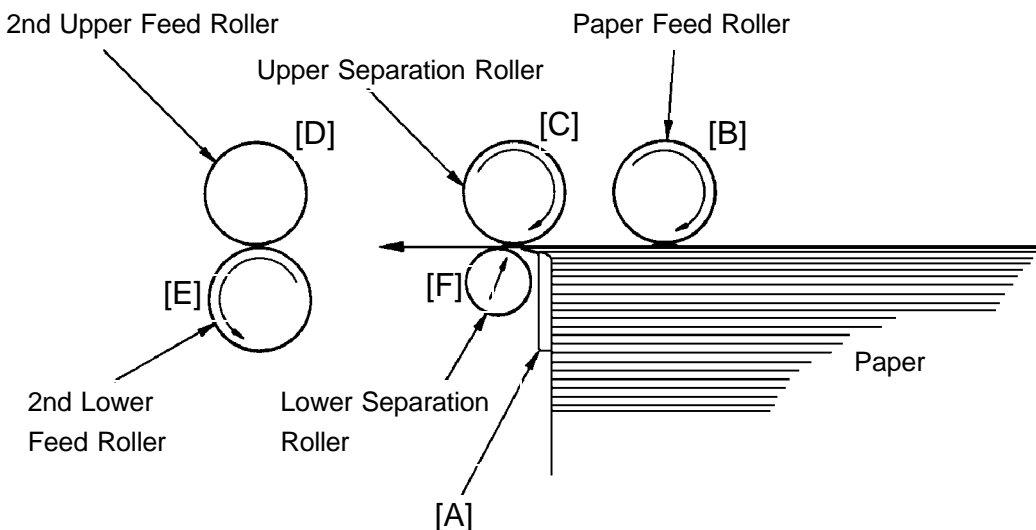

- [A]: Separation Plate
- [B]: Paper Feed Roller
- [C]: Upper Separation Roller
- [D]: 2nd Upper Feed Roller
- [E]: 2nd Lower Feed Roller
- [F]: Lower Separation Roller

This machine uses a center separation system, which consists of the separation plate [A] and rollers, is used instead of the corner separation system. Also, the paper table is lifted and lowered by a motor.

## 5.2 PAPER FEED ROLLER/UPPER SEPARATION ROLLER MECHANISM

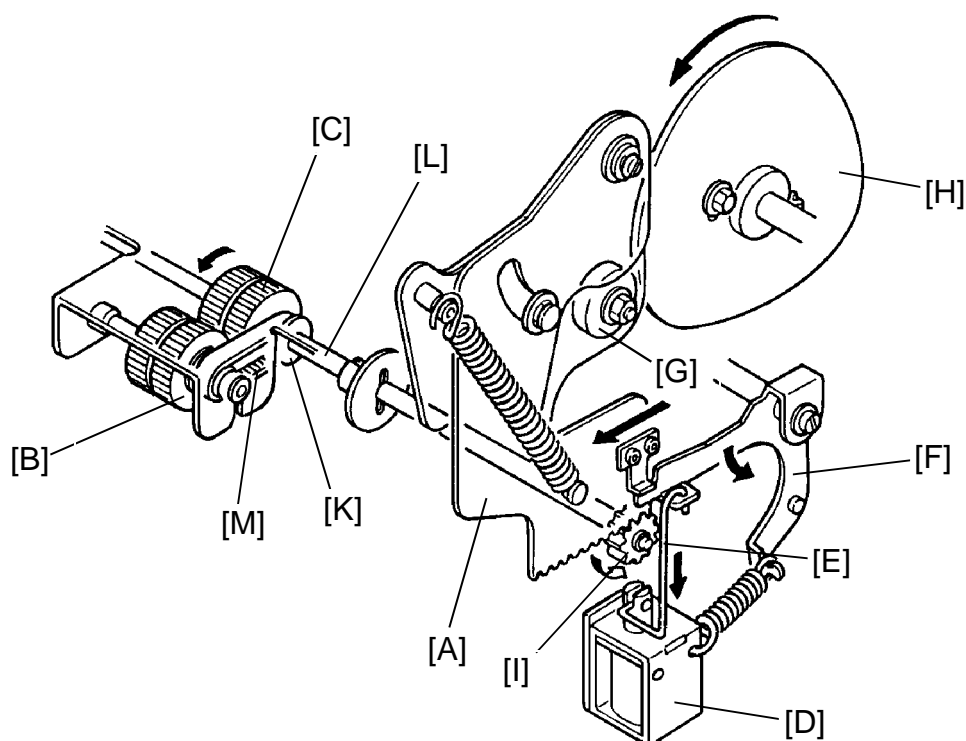

The sector gear [A], located on the non-operation side, rotates the paper feed roller [B] and the upper separation roller [C]. When the paper feed solenoid [D] turns on, the link [E] is pulled and the sector stopper [F] turns counterclockwise. This is because the sector gear lock is released when the cam roller [G] is positioned on the top of the paper feed roller cam [H]. Then, the cam roller [G] of the sector gear moves along the cam face of the paper feed roller cam [H].

When moving the cam roller [G] from the bottom to the top of the paper feed roller cam [H], the sector gear [A] turns clockwise and the gear [I] is turned counterclockwise. The rotation of the gear [I] is transmitted to the upper separation roller shaft [J] by the one-way clutch inside the gear [I], and the upper separation roller [C] turns counterclockwise.

At the same time, the pulley [K] mounted on the upper separation roller shaft [L] turns, and the belt [M] rotates the paper feed roller [B] counterclockwise to feed the printing paper.

When the cam roller [G] moves from the top to the bottom of the paper feed roller cam [H], the sector gear [A] turns counterclockwise and the gear [I] is turned clockwise. However, due to the one-way clutch inside the gear [I], the upper separation roller [C] and the paper feed roller [B] do not turn.

## 5.3 FEED ROLLER PRESSURE MECHANISM

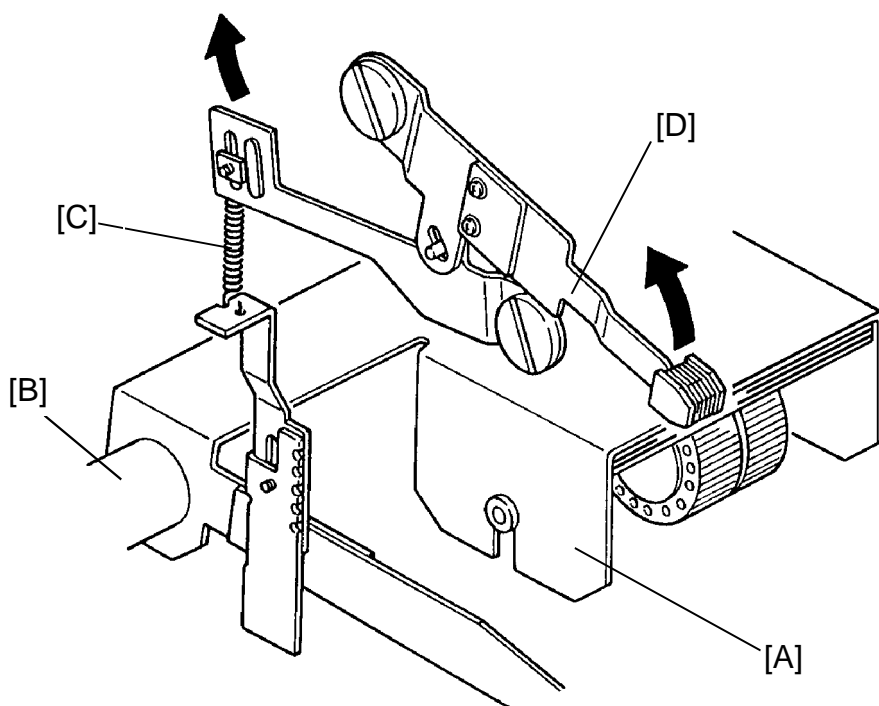

The feed roller assembly [A] rotates clockwise around its shaft [B] due to the weight of assembly.

The feed roller rotation is resisted by the feed roller pressure spring [C].

The force difference between the feed roller assembly weight and the pressure spring force is applied to the paper as a feed roller pressure.

The feed roller pressure can be changed by moving the feed- pressure lever [D] up or down as shown in the figure.

## 5.4 SEPARATION MECHANISM

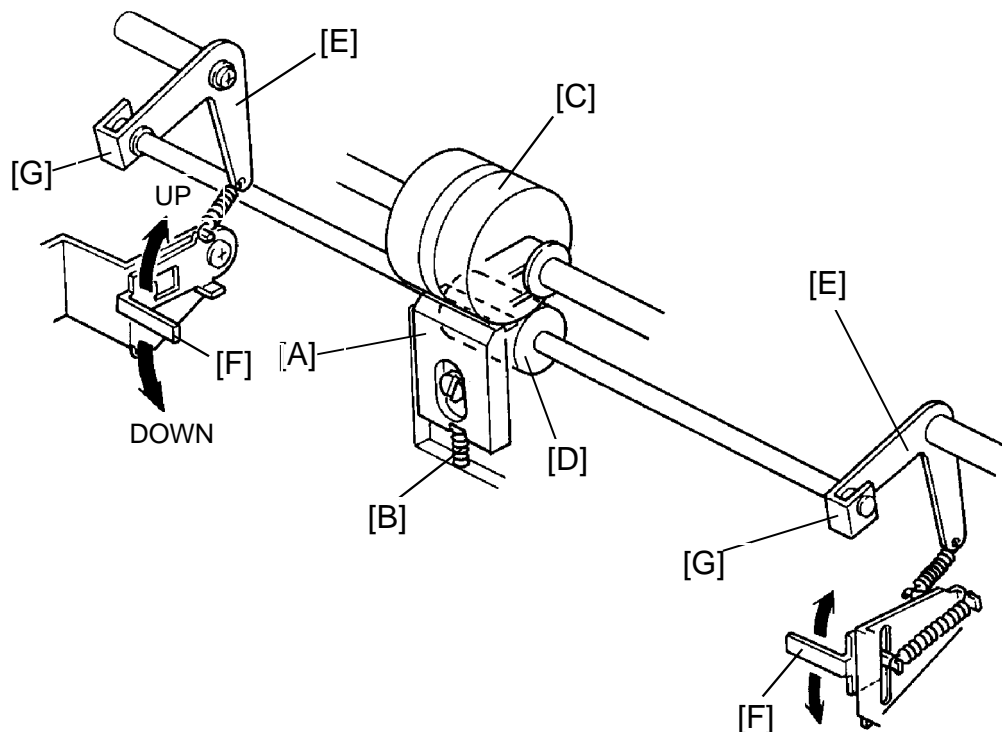

The separation plate [A] is in contact with the upper separation roller [C] due to the spring [B]. This is to prevent multiple paper feed.

As the lower separation roller [D] does not turn clockwise due to the one way clutch bearings [G] provided on both right and left separation levers [E], the sheets are separated and a sheet of paper is fed to the second feed rollers. When 2 sheets of paper are fed, brake force is applied to the lower sheet of paper.

The pressure between upper and lower separation rollers can be adjusted in two steps by changing the right and left separation pressure adjusting levers [F].

Up (Weak position)	→	Spring tension and separation pressure decrease.
Down (Standard position)	→	Spring tension and separation pressure increase.

## 5.5 SEPARATION ROLLER PRESSURE RELEASE MECHANISM

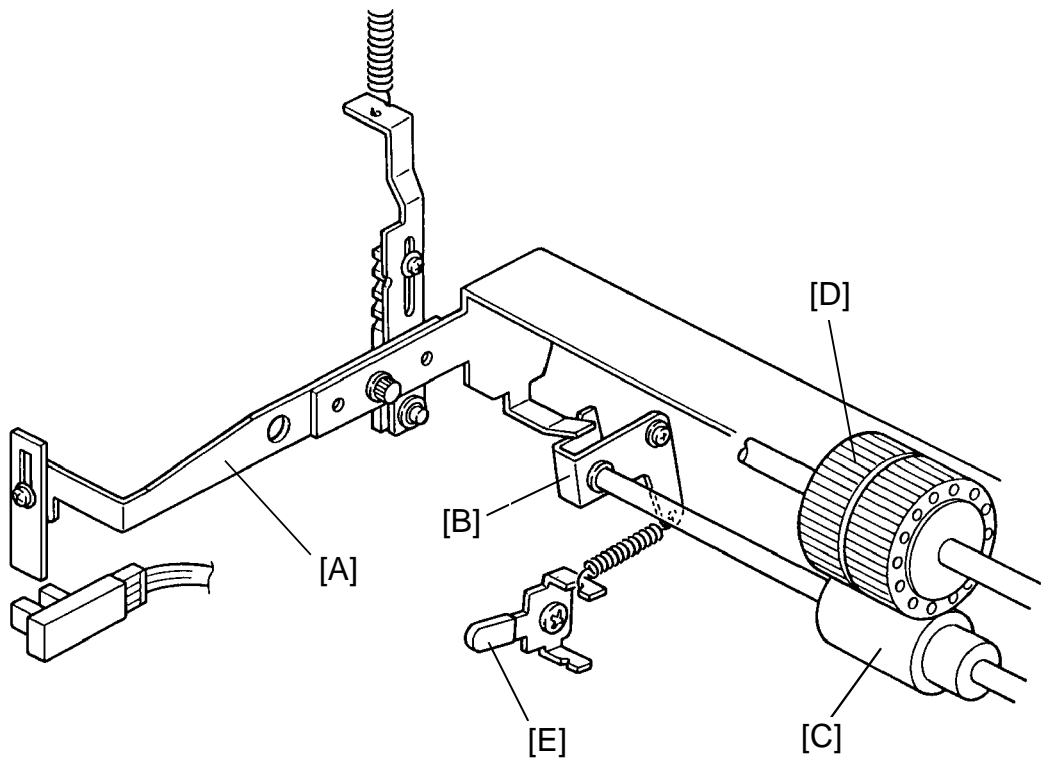

- [C]: Lower Separation Roller
- [D]: Upper Separation Roller
- [E]: Separation Pressure Adjusting Lever

When the paper table lowers the paper feed roller lever [A] also lowers and presses the left separation lever [B] to release the separation roller pressure.

This mechanism makes misfed paper removal easy.



## 5.6 SECOND FEED ROLLER MECHANISM

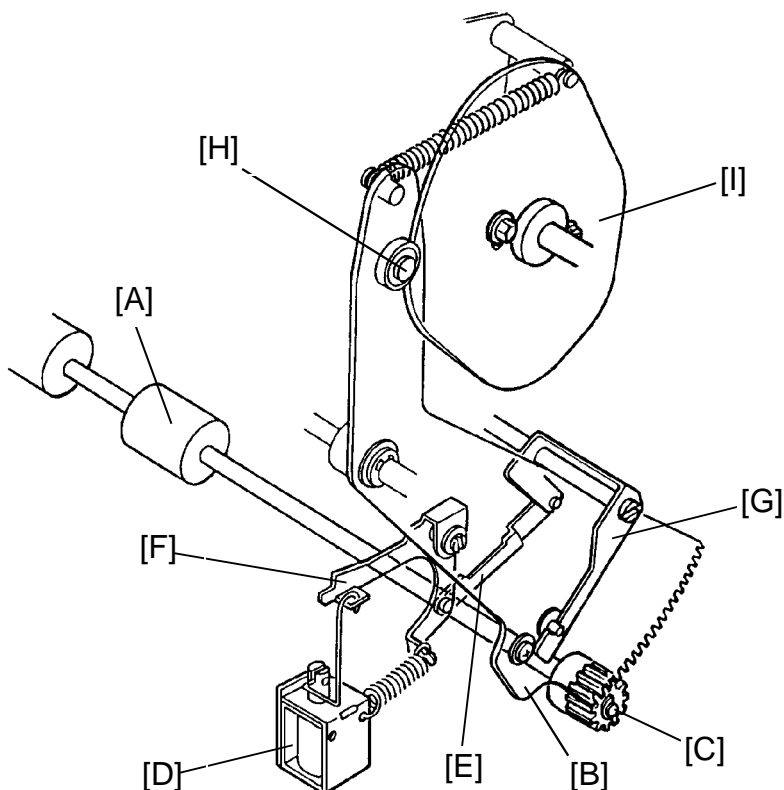

The lower second feed roller [A] is driven by the sector gear [B] and the gear [C]. When the paper feed solenoid [D] turns on, the link [E] combined with the paper feed roller sector stopper [F] is pulled and the second feed roller sector stopper [G] turns counterclockwise.

When the bearing [H] of the sector gear comes to the top of the lower second feed roller cam [I], the stopper [G] is released from the sector gear [B] as a clearance is formed between the pin of the sector gear and the stopper. Therefore, the bearing of the sector gear moves along the second feed roller cam face.

When turning the gear [C] counterclockwise, its rotation is not transmitted to the lower second feed roller due to the one-way clutch bearing press-fit into the gear [C].

When the bearing [H] of the sector gear moves up from the bottom of the second feed roller cam [I], the sector gear turns counterclockwise and gear [C] turns clockwise. As the rotation of the gear [C] is transmitted to the lower second feed roller, the lower second feed roller turns clockwise to feed the paper to the drum section.

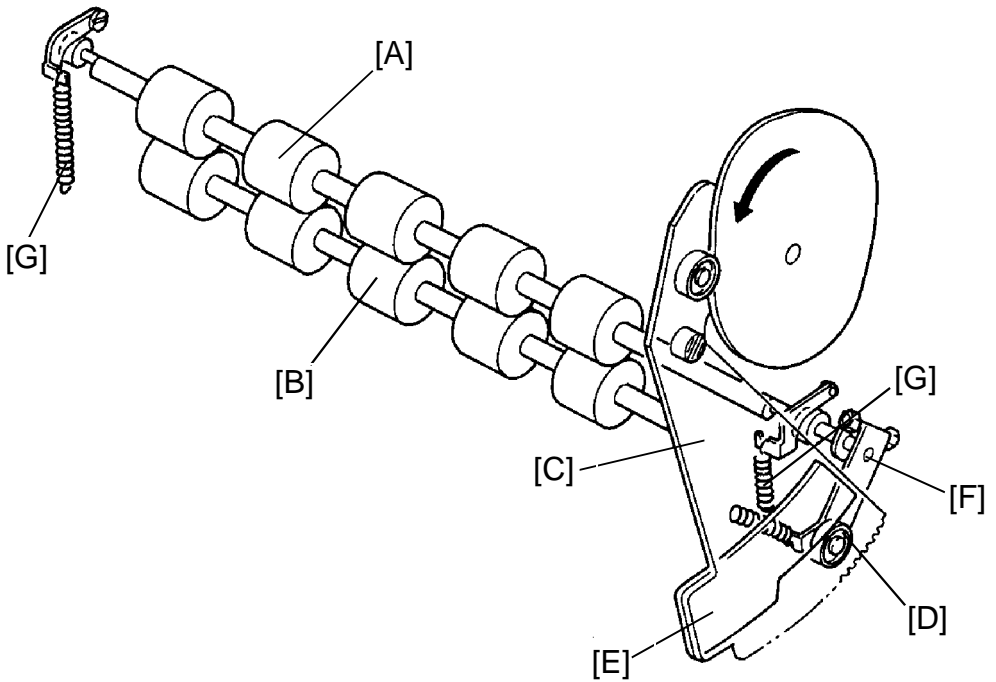

Normally, the upper second feed roller [A] does not contact the lower second feed roller [B]. When the second feed roller sector gear [C] is moved, the upper second feed roller moves against the lower second feed roller to feed paper to the drum section.

When the sector gear [C] turns clockwise, the bearing of the lever [D] moves down from the top of the cam [E] mounted behind the sector gear, and the lever [D] and the upper roller shaft [F] turn clockwise.

As the upper roller shaft [F] is an eccentric shaft, the upper second feed roller [B] contacts the lower second feed roller and the upper second feed roller is turned by the friction of the lower second feed roller. Springs [G] apply tension to both the right and left sides of the upper second feed roller.

## 5.7 PAPER TABLE UP/DOWN MECHANISM

The paper table is raised and lowered by the paper table drive motor [A].

The paper end sensor [B] is actuated when the paper is set on the paper table. When the Print Start key is pressed, the paper table drive motor starts turning clockwise (X direction) and the worm gear [C] also turns. The worm wheel [D] turns clockwise and the gears [E] on the both sides turn to raise the racks [F].

As the paper table rises, the paper pushes against the paper feed rollers [G]; thereby, raising the lever [H] which is mounted on the feed roller cover. This activates the paper table height sensor [I] (the phototransistor senses the light from the photocoupler, which up to now was cut off by the lever), causing the paper table motor to turn OFF and stop raising the paper table.

As printing proceeds and the paper level runs down, the lever [H] cuts off the light of photocoupler and the paper table motor turns clockwise until the phototransistor is reactivated. As a result, the top of the paper stack is constantly kept at the correct height.

When no paper is present, the paper end sensor is not activated and the paper table motor turns counterclockwise (Y direction) to lower the paper table. The paper table is lowered until the actuator [J] interrupts the lower limit sensor [K].

When a misfeed occurs, the paper table motor turns counterclockwise (Y direction) for one second, slightly lowering the paper table.

**NOTE:** The VT2100/VT2130/VT2150 use a photo interrupter sensor instead of a photo reflective sensor [B].

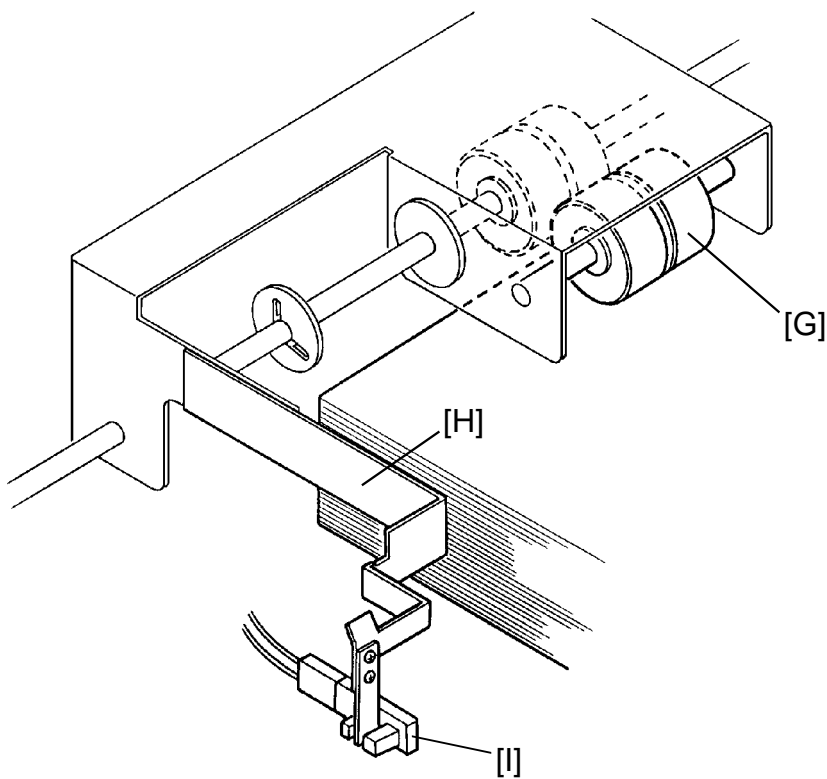
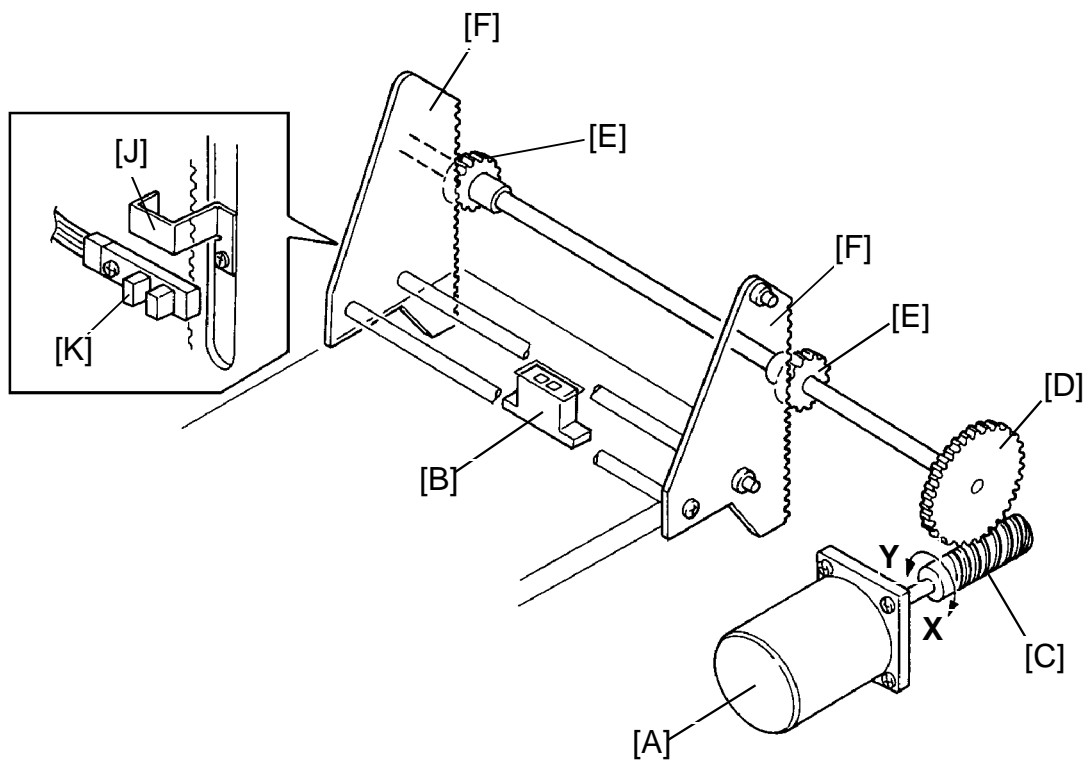

## 5.8 SIDE REGISTRATION MECHANISM

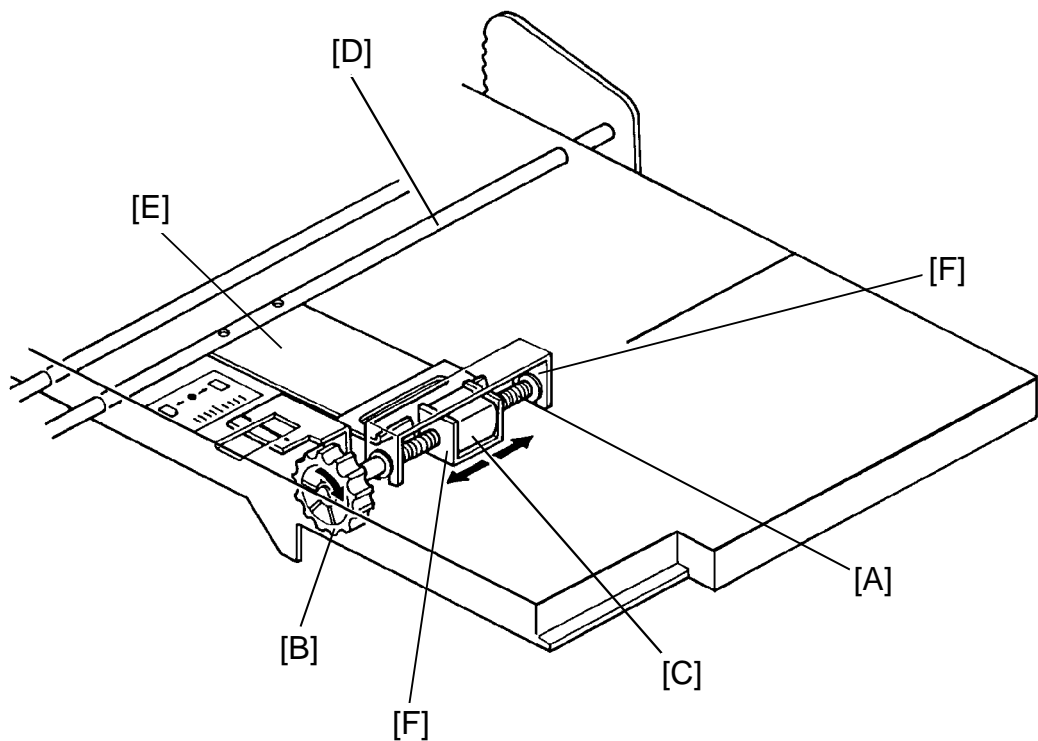

The shaft [A] of the fine adjusting dial [B] is threaded. The inside of the sleeve [C] is also threaded. The sleeve is fixed to the feed table stay [D] through a bracket [E].

The feed table brackets [F] mounted under the table are fixed on the both ends of the adjusting dial shaft.

When the fine adjusting dial is turned clockwise and the feed table moves to the right.

## 5.9 PAPER SIZE DETECTION: VT2300/VT2500

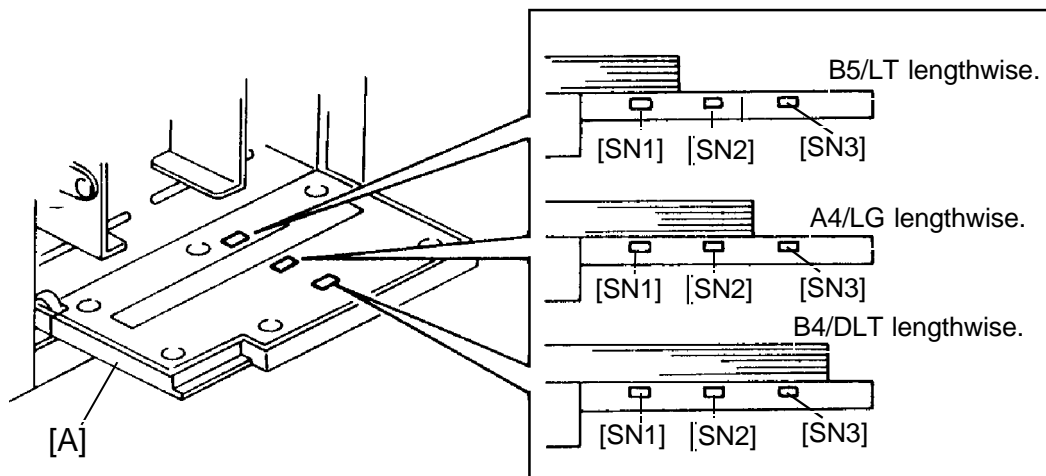

The size of the paper set on the paper table is detected by the three paper size sensors (photo sensors) mounted on the paper table [A].

The master making process (Master feed direction only) is controlled according to the detected paper size so that ink will not be transferred to the pressure roller when the printing paper is smaller than the image on the master. Paper size sensors [SN1], [SN2], and [SN3] detect the paper size before the master making process starts. The master making length in the master feeding direction is determined by sensor ON/OFF states as shown below.

A4 Version:

Paper Size	Paper Size Sensor			Master Making Length in Normal Mode	Master Making Length in Combine 2 Originals Mode	
	SN1	SN2	SN3		More than 100% ratio	Less than 93% ratio
A3/B4 lengthwise	ON	ON	ON	354 mm	354 mm	354 mm
A4 lengthwise	ON	ON	OFF	287 mm	287 mm	291.1 mm
B5 lengthwise	ON	OFF	OFF	247 mm	247 mm	251.3 mm
A5 lengthwise B5 sideways	OFF	OFF	OFF	172 mm	172 mm	203.1 mm

LT Version:

Paper Size	Paper Size Sensor			Master Making Length in Normal Mode	Master Making Length in Combine 2 Originals Mode	
	SN1	SN2	SN3		More than 100% ratio	Less than 93% ratio
DLT lengthwise	ON	ON	ON	354 mm (13.9")	354 mm (13.9")	354 mm (13.9")
LG lengthwise	ON	ON	OFF	345.6 mm (13.6")	345.6 mm (13.6")	345.6 mm (13.6")
LT lengthwise	ON	OFF	OFF	269.4 mm (10.6")	269.4 mm (10.6")	269.4 mm (10.6")
HLT lengthwise	OFF	OFF	OFF	205.9 mm (8.1")	205.9 mm (8.1")	205.9 mm (8.1")

## 5.10 PAPER END DETECTION: VT2300/VT2500

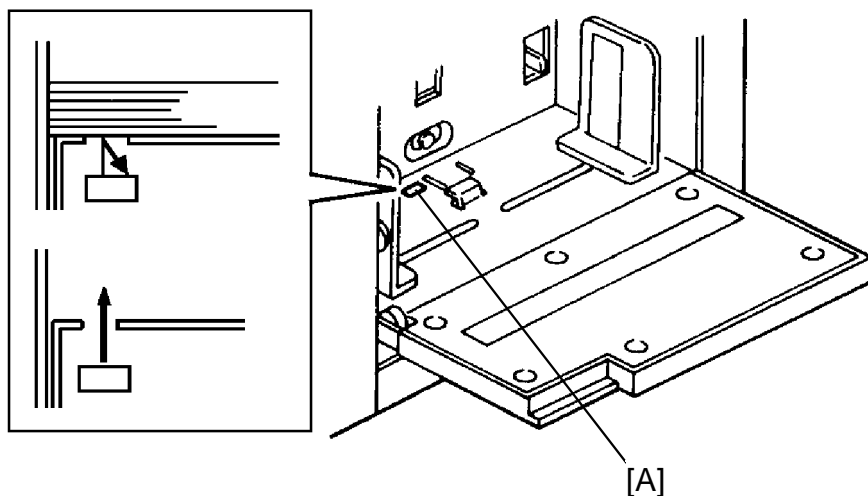

A reflective sensor [A] (non-actuator type) is used to detect paper end. This makes it possible for the optional paper cassette to be installed on the paper table.

## 5.11 OPTIONAL B4 PAPER CASSETTE: VT2300/VT2500

The optional B4 paper cassette is the universal type. The paper guide plates can be adjusted to accommodate different paper sizes.

Side plate width settings	:	180_260 mm (7.1" x 10.2")
Rear plate length settings	:	178_188 mm (7.0" x 7.4"),
Paper cassette capacity	:	500 sheets (66.3 g/m <sup>2</sup> /17.6 lb)

25

## 5.12 ELECTRICAL TIMING

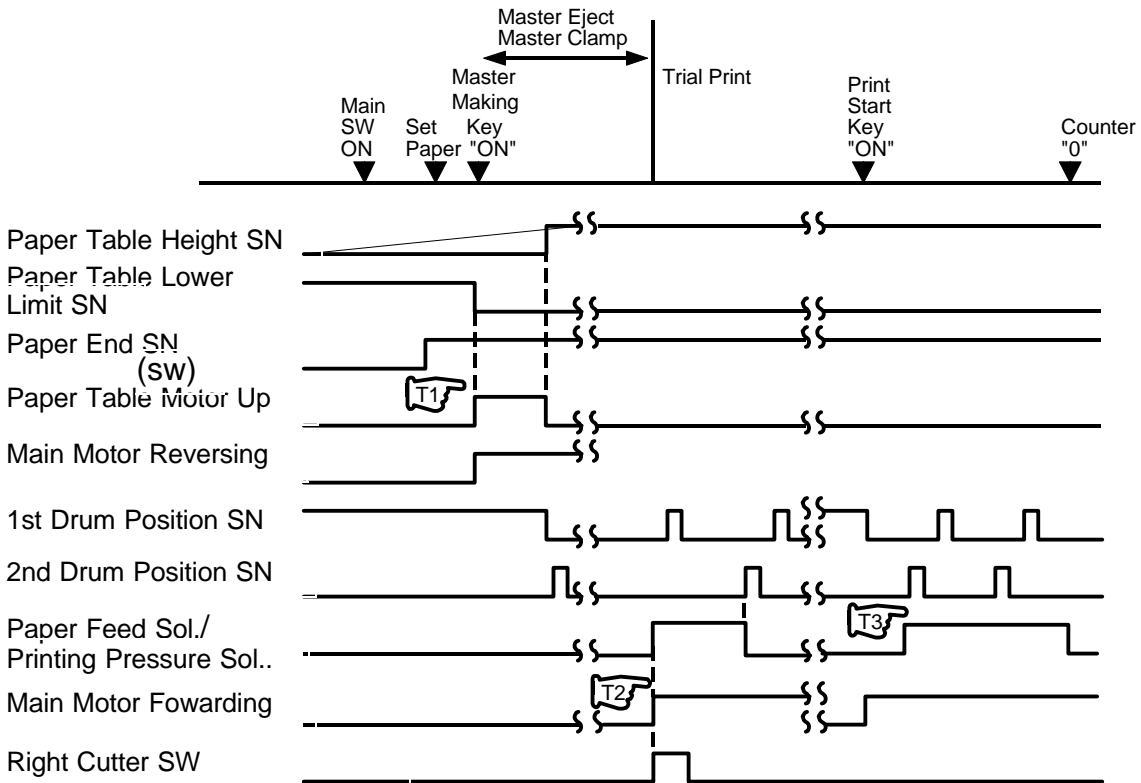

( ): VT2100/VT2130/VT2150

- T1: When the paper end sensor is not actuated and the Master Making key is pressed, the paper table up signal turns on RA303 and the paper table motor rotates to raise the paper table. The paper table motor turns off when the paper table height sensor turns on. At the same time main motor starts rotating in the reverse direction.
- T2: After the master eject and master clamping process are over and the cutter motor is driven to the right position (right cutter switch ON) the paper feed solenoid and the printing pressure solenoid turn on. It turns off when the second drum position sensor turns on.
- T3: When the Print Start key is pressed, the main motor starts rotating. When the second drum position sensor turns on, the paper feed solenoid and the printing pressure solenoid turn on again to start printing. The paper feed solenoid and the printing pressure solenoid turn off when the copy counter indicates "0".



### 5.13 CIRCUIT: VT2300/VT2500

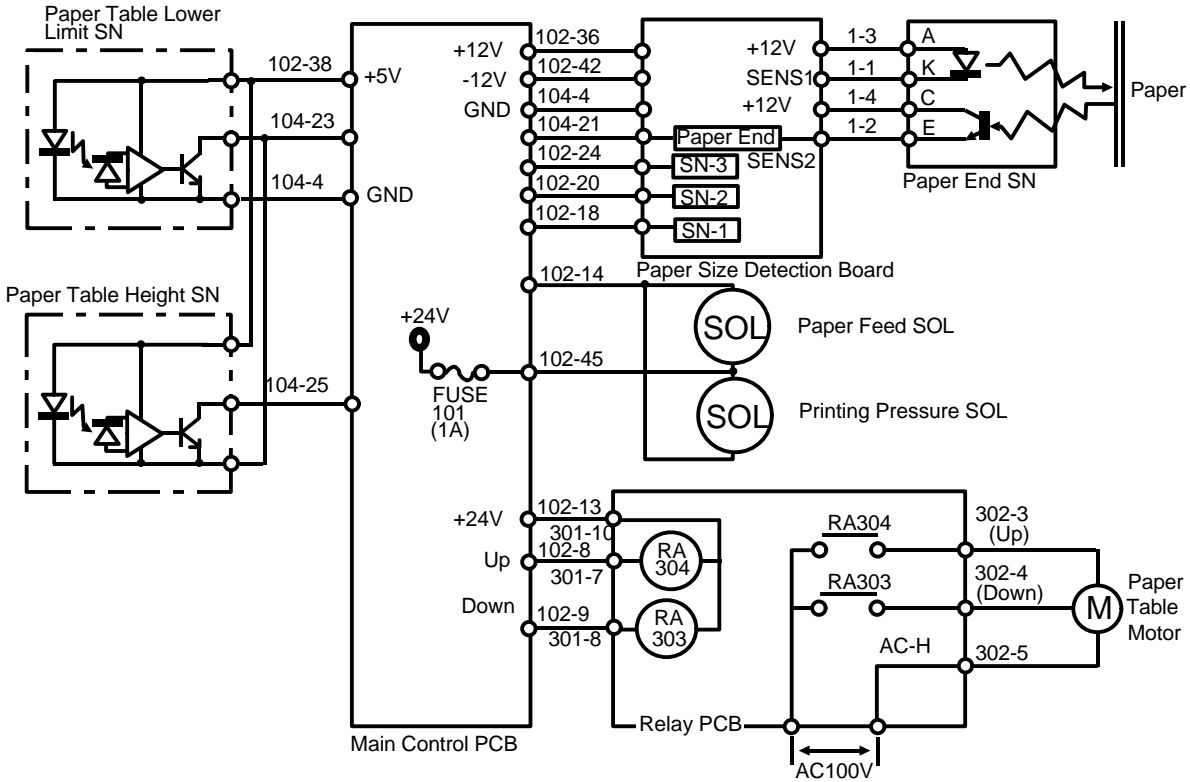

### 5.14 INPUT/OUTPUT: VT2300/VT2500

Signal Name	I/O	Main Control PCB		Description
		CN No	Level	
Paper Table Lower Limit Sensor	I	104-23		When the actuator is in the sensor, the voltage at CN104-23 is 7.5 V Pulse.
Paper Table Height Sensor	I	104-25		When the actuator is in the sensor, the voltage at CN104-25 is 7.5 V pulse.
Paper End Sensor	I	104-21		When paper is present, the voltage at CN104-21 is 5.0 V pulse.
Paper Size Detection Sensor 3	I	102-24		When paper is present, the voltage at CN102-24 is 0 V.
Paper Size Detection Sensor 2	I	102-20		When paper is present, the voltage at CN102-20 is 0 V.
Paper Size Detection Sensor 1	I	102-18		When paper is present, the voltage at CN102-18 is 0 V.
Paper Feed Solenoid	O	102-14		When the solenoid turns on, the voltage at CN102-14 is 0 V.
Relay: Paper Table Up	O	102- 8		When the paper table is being raised, the voltage at CN102-8 is 0 V.
Relay: Paper Table Down	O	102- 9		When the paper table is being lowered, the voltage at CN102-9 is 0 V.

## 5.15 CIRCUIT: VT2100/VT2130/VT2150

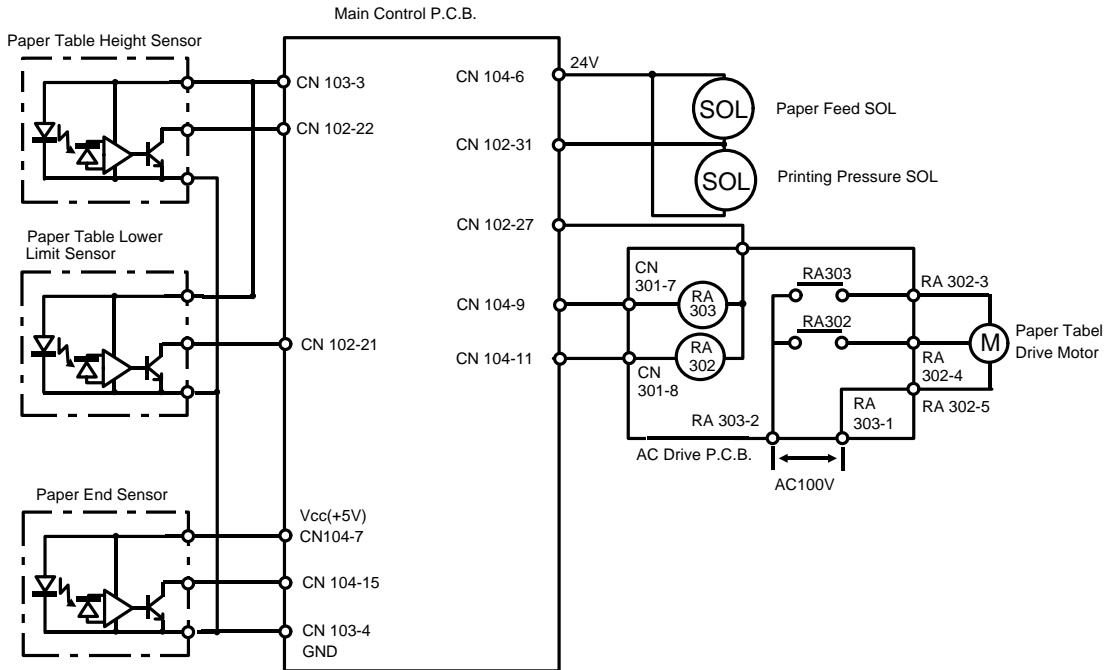

## 5.16 INPUT/OUTPUT: VT2100/VT2130/VT2150

Signal Name	I/O	Main Control PCB		Description
		CN No	Level	
paper Feed Solenoid	O	102-31		When the solenoid turns on, the voltage at CN102-31 is 0V
Paper Table Height Sensor	O	102-22		When the actuator is out of the sensor, the voltage at CN102-22 is 0V
Paper Table Lower Limit Sensor	O	102-21		When the actuator is out of the sensor, the voltage at CN102-21 is 0V
Relay: Paper Table Up	O	104-9		When the paper table is being raised, the voltage at CN104-9 is 0V
Relay: Paper Table Down	O	104-11		When the paper table is being raised, the voltage at CN104-11 is 0V
Paper End Sensor	O	104-15		When paper is present, the voltage at CN104-15 0V

## 6. PRINTING SECTION

---

### 6.1 OVERALL

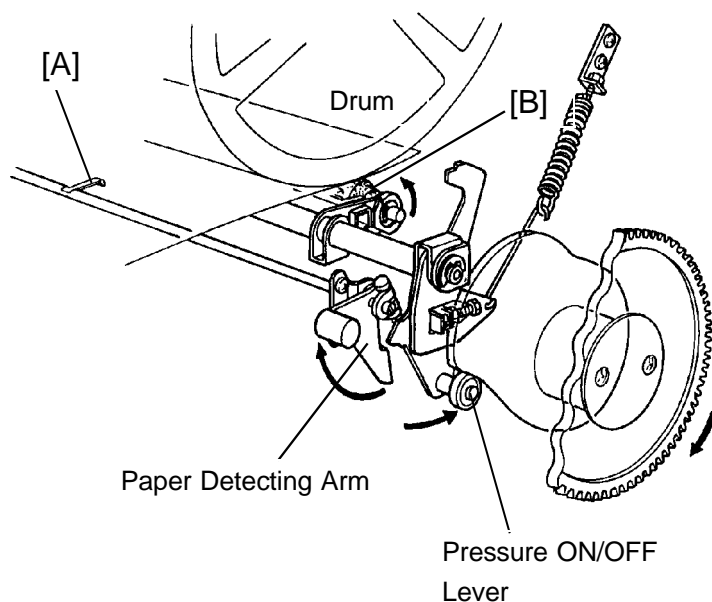

In this section, the paper detecting feeler [A] detects whether paper is fed correctly to the second paper feed roller section or not.

Only when the paper is correctly fed, printing pressure is applied (the pressure roller [B] contacts the drum) to transmit the ink from the master to the printing paper.

## 6.2 PAPER DETECTING AND PRINTING PRESSURE ON/OFF MECHANISM

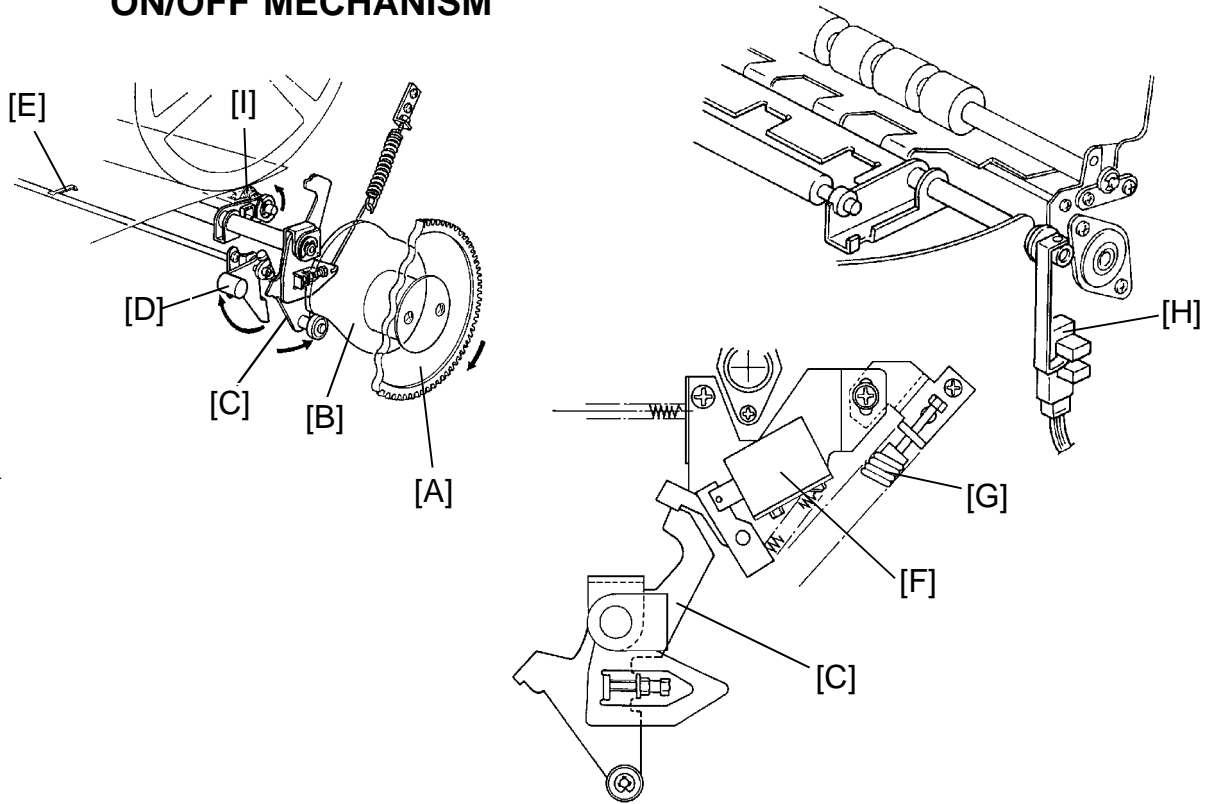

Printing Pressure ON → Printing Pressure sensor [H] is not interrupted.  
 Printing Pressure OFF → Printing Pressure sensor [H] is interrupted.

The main motor turns the gear [A], thus rotating the pressure cam [B]. During the printing process, the pressure cam [B] turns clockwise as the main motor turns clockwise. When paper is not fed, the pressure ON/OFF lever [C] is locked by the paper detecting arm [D]. However, when paper is fed, the bearing of the pressure ON/OFF lever [C] rides up on the top of the pressure cam [B] and slight clearance is made between the paper detecting arm [D] and the pressure ON/OFF lever [C]. At this moment, the paper turns the paper detecting feeler [E] slightly clockwise and a clearance forms in the lock section. Therefore, the paper detecting arm [D] turns clockwise, releasing the lock of the pressure ON/OFF lever [C]. Also, the printing pressure solenoid [F] turns on to release the pressure ON/OFF lever [C]. As a result, the bearing of the pressure ON/OFF lever [C] moves along the pressure cam [B] and the pressure roller [I] moves against the drum for printing.

The printing pressure is determined by the pressure spring [G] which is adjustable. The printing pressure sensor [H] is not interrupted when the pressure roller [I] comes near the drum.

## 6.3 PRINT PRESSURE RELEASE MECHANISM

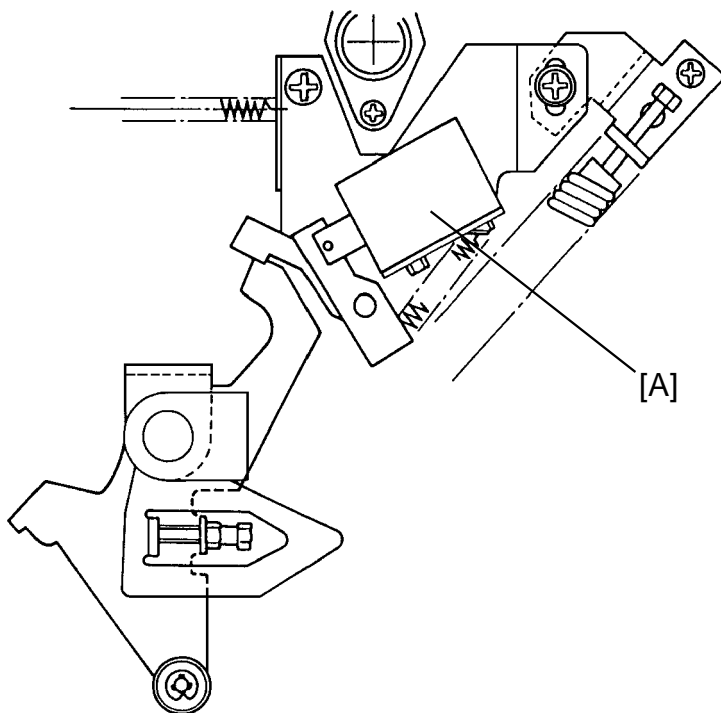

This release mechanism prevents deformation of the drum and the pressure roller when the drum is pulled out to remove misfed paper.

The printing pressure solenoid [A] is energized/de-energized at the same time as the paper feed solenoid.

When a paper misfeed occurs, the paper feed solenoid and the printing pressure solenoid are de-energized but the print pressure is still applied to the drum. This print pressure is released when the drum rotates to the drum home position after the drum rotation button is pressed.

This printing pressure release mechanism works even if the paper detecting feeler is actuated by the misfed paper.

## 6.4 CIRCUIT

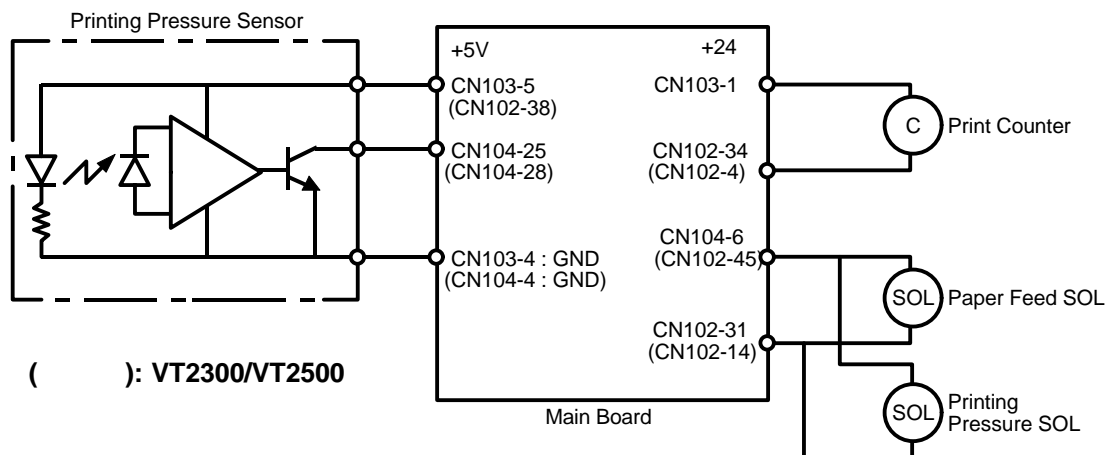

## 6.5 INPUT/OUTPUT

Signal Name	I/O	Main Control PCB		Description
		CN No.	Level	
Printing Pressure Sensor	I	CN104-25 (CN104-28)		When the pressure is applied the voltage at CN104-25(CN104-28) is 0 V.
Printing Pressure Solenoid	O	CN102-31 (CN102-14)		When the printing pressure solenoid turn on, the voltage at CN102- 31(CN102-14) 0 V.

( ): VT2300/VT2500

## 6.6 ELECTRICAL TIMING

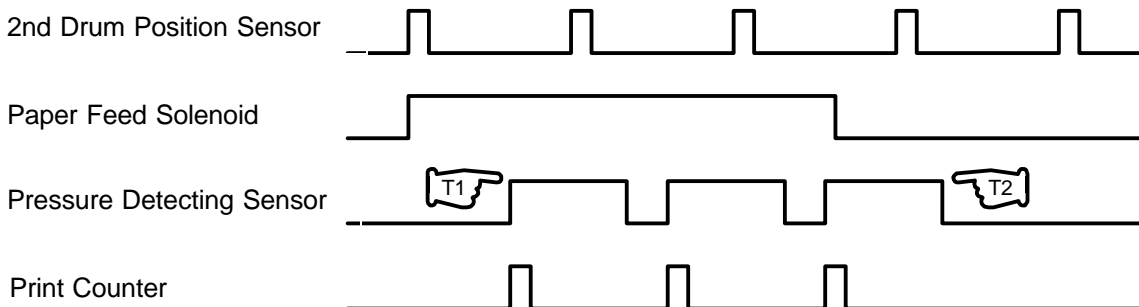

T1: When the printing pressure is applied and the printing pressure sensor is not interrupted, the print counter signal is applied for 100 milliseconds to increase the print counter and decrease the counter on the operation panel.

T2: When the printing pressure sensor is not interrupted and the copy counter on the operation panel indicates "0", the paper feed solenoid and the printing pressure solenoid turn off to stop paper feeding and to release the printing pressure.

## 7. DRUM SECTION

### 7.1 OVERALL

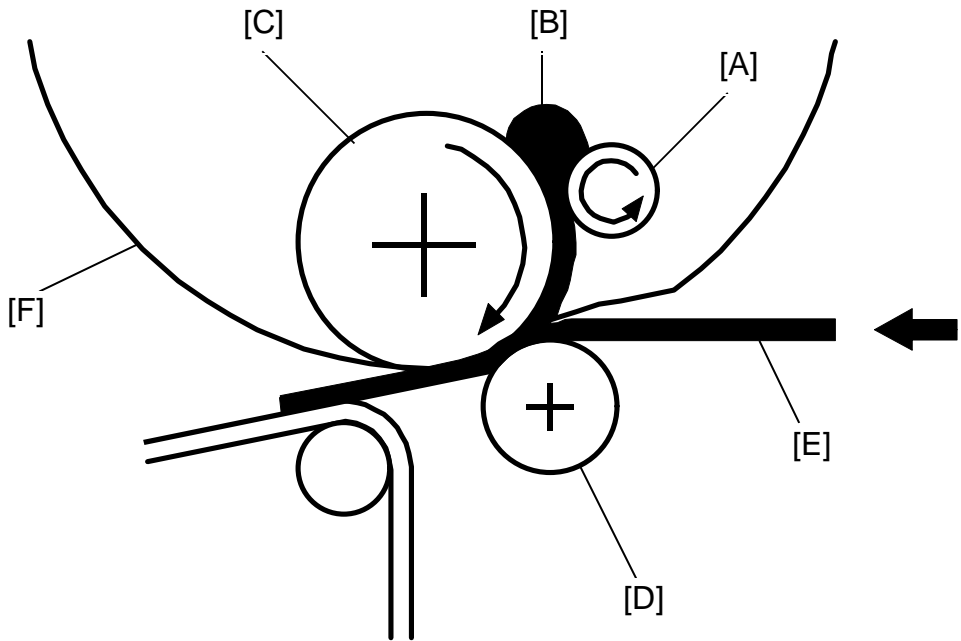

- [A]: Doctor Roller
- [B]: Ink
- [C]: Ink Roller
- [D]: Pressure Roller
- [E]: Paper
- [F]: Drum

In this section, ink is supplied from the ink cartridge and is applied to the ink roller uniformly. The ink is then transferred to the printing paper through the holes in the master.

## 7.2 DRUM ROTATION MECHANISM

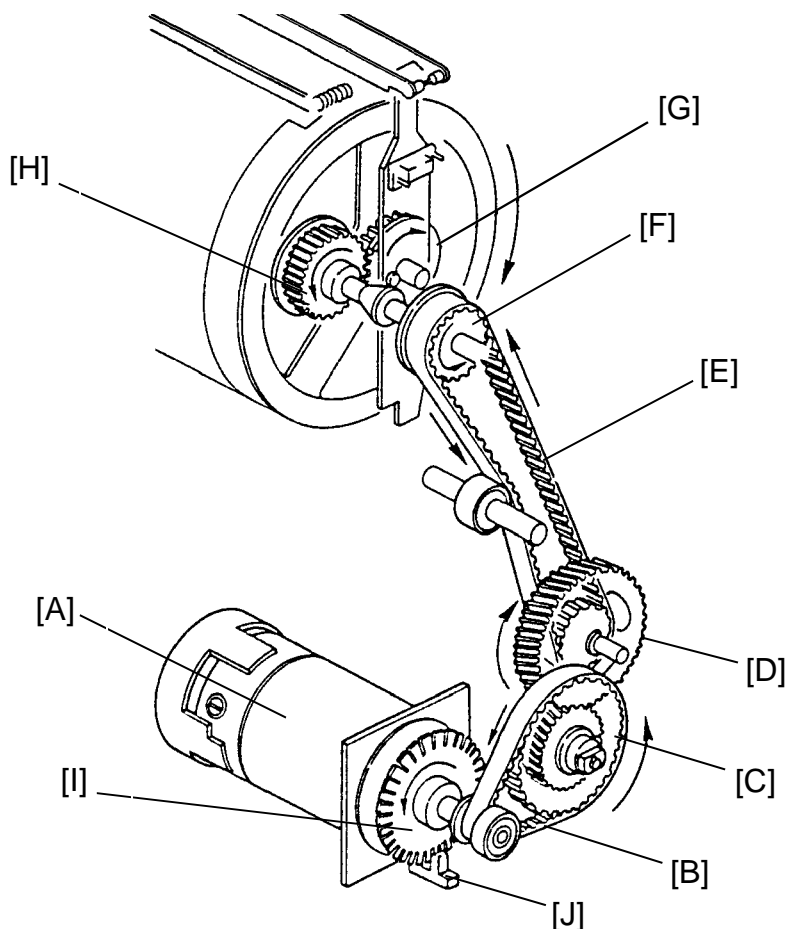

The main motor (DC motor) [A], located under the rear side plate, turns the drum either clockwise or counterclockwise by means of belt [B], gears [C] [D], belt [E], and pulley [F].

The drive mechanism uses helical gears, which turn more quietly. Gear [H] at the rear of the machine and gear [G] at the rear end of the drum unit have special grooves that prevent gear [G] from engaging gear [H] if gear [H] is not at the correct position.

Pulse disk [I] and sensor [J] on the main motor shaft check the drum rotation speed.

When the drum is at the original stop position, the drum actuator interrupts the first drum position sensor and the drum unit can be pulled out from the machine.

**NOTE:** VT2100/VT2130/VT2150 use a gear instead of a timing belt [B].



## 7.3 DRUM LOCK MECHANISM 1

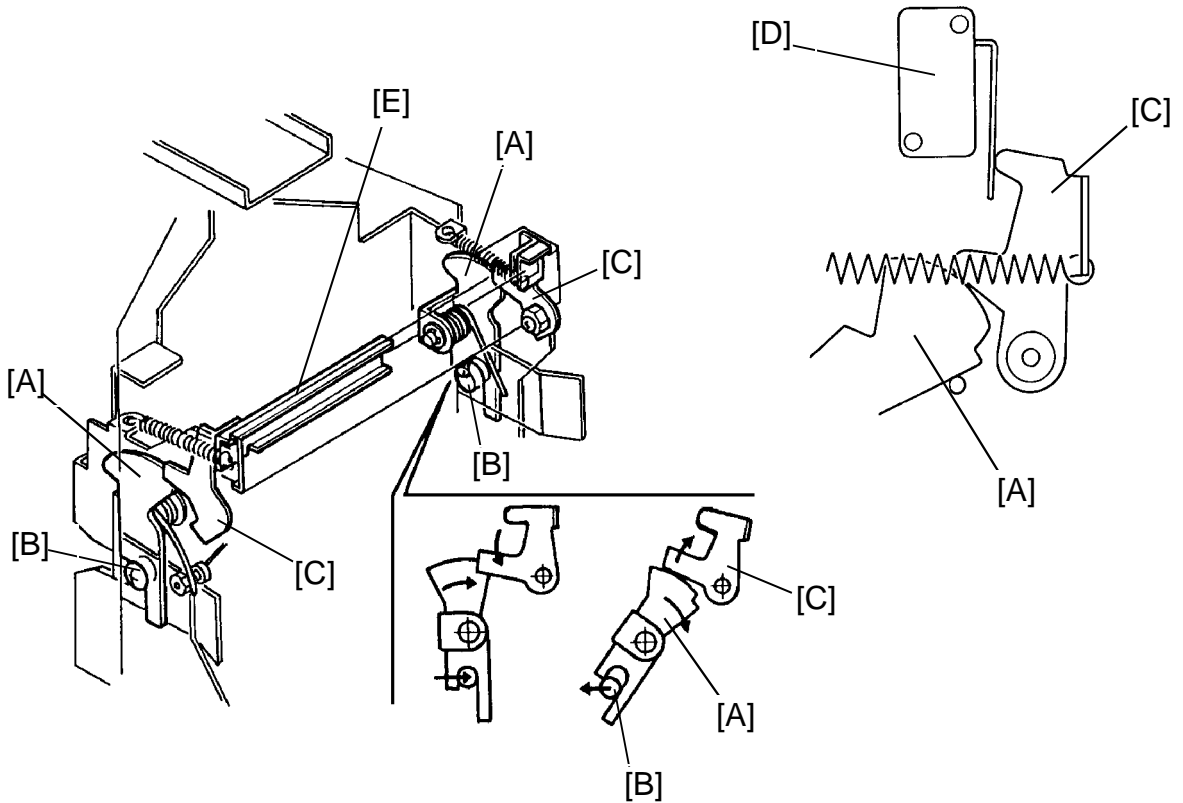

When the drum unit is set in the machine, the arm [A] is turned counter-clockwise by the lock pin [B]. The top of the arm is locked by the stopper [C] to lock the drum in the machine completely. At the same time, the drum detecting switch [D] is turned on by the top of the stopper [C].

When pulling the lever [E] to the operation side, the stopper [C] is turned clockwise and the stopper is released from the arm [A] due to spring tension. Therefore, the locking mechanism of the drum is also released.

## 7.4 DRUM LOCK MECHANISM 2: VT2300/VT2500

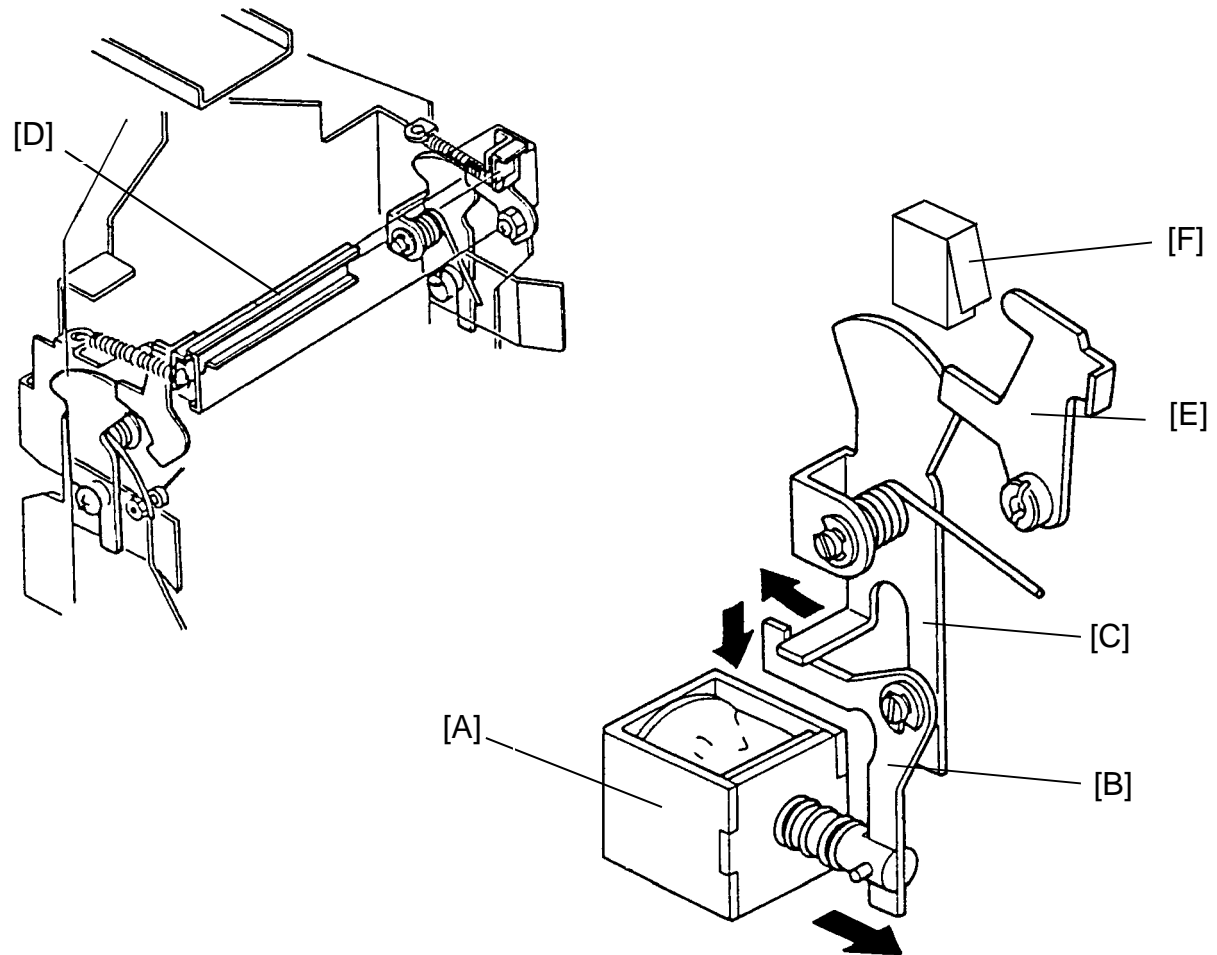

The drum lock solenoid [A] turns on when the copy cycle is interrupted by opening a cover or turning off the main switch. Arm [B] then locks arm [C] in place. This prevents the drum from being removed.

When lever [D] is pulled towards the front of the machine, arm [E] raises and the drum safety switch [F] turns off. With the safety switch off, the drum will not rotate when the Drum Rotation button is pressed. Push in on the drum handle to turn on the safety switch and enable the Drum Rotation button.

**NOTE:** Lever [D] is pulled out when the user attempts to pull the drum unit out before returning the drum to the original position.

## 7.5 DRUM LOCK MECHANISM 3

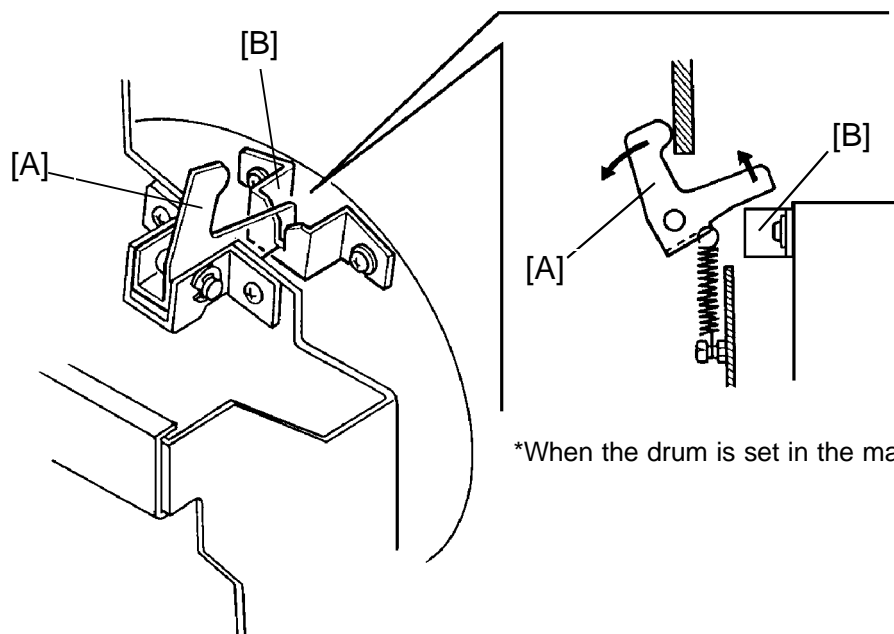

\*When the drum is set in the machine.

To prevent the drum from rotating when the drum is pulled out of the machine, the drum stopper [A] drops into the drum lock [B] to secure the drum.

When the drum is installed in the machine, the drum stopper [A] is held out of the drum lock by the side plate of the machine.

## 7.6 DRUM LOCK MECHANISM 4

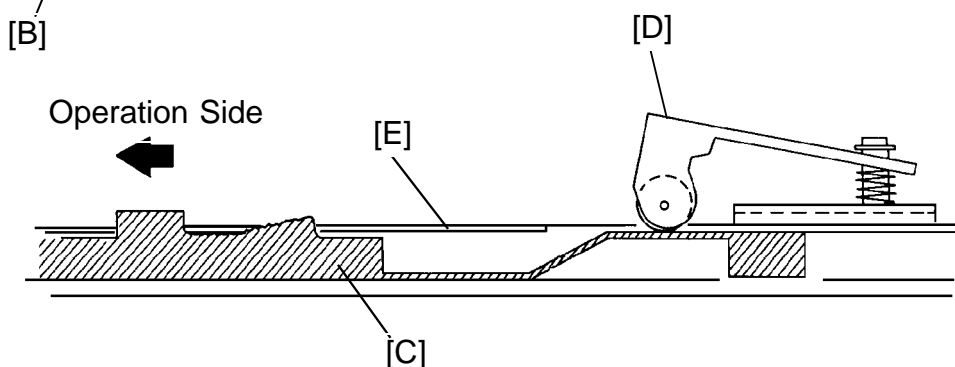
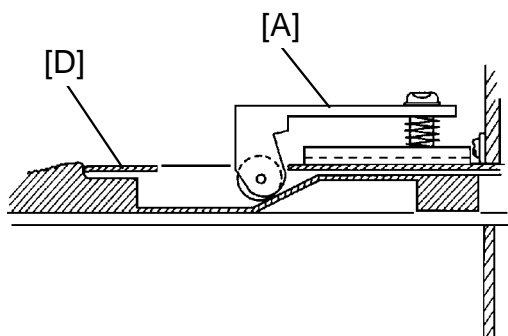
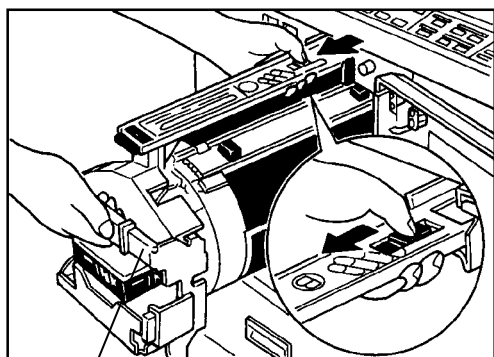

When the drum is pulled out, the drum stopper [A] drops down into the hole as shown in the figure and the drum stopper stops the drum unit from being pulled out any further.

In this condition, if the operator pull the handle [B], the drum unit cannot drop.

When the stopper releasing lever [C] is moved to the operation side as illustrated in the direction of the allow, the drum stopper releasing lever pushes up the drum stopper [D] to the same level as the drum rail cover[E]. This allows the drum to be removed.



## 7.8 INK KNEADING MECHANISM

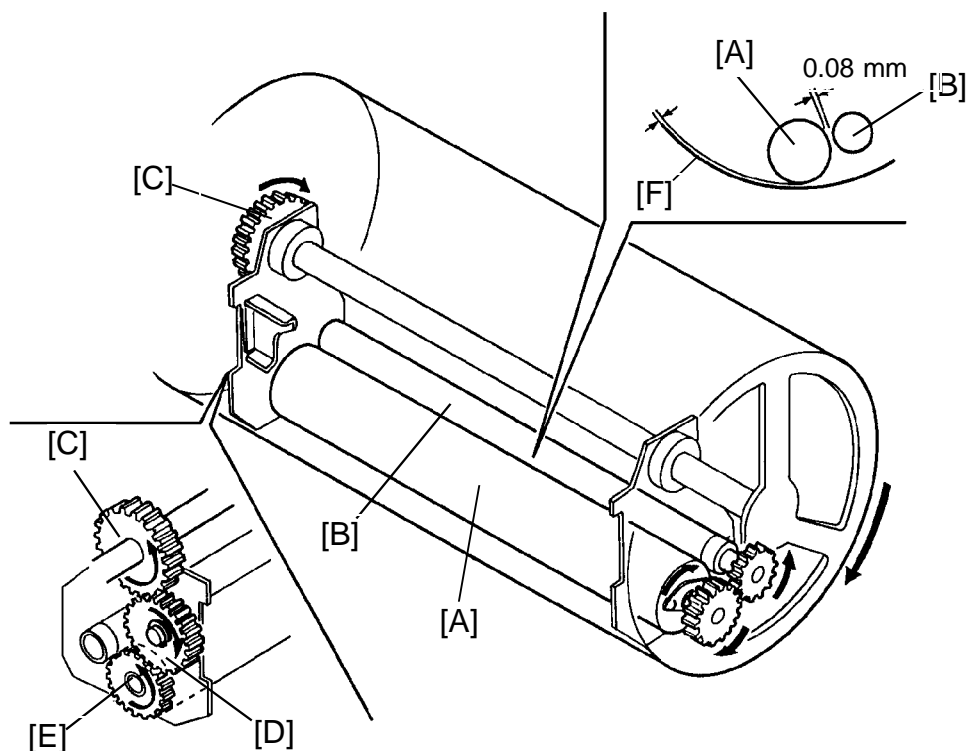

The ink kneading mechanism consists of the ink roller [A] which rotates with the drum and the doctor roller [B] which ensures that the ink is supplied evenly to the ink roller.

The ink roller rotates due to the gear [C], which rotates with the drum, through idle gear [D] and gear [E] mounted on the ink roller. The ink roller rotates 1.5 times faster than the drum.

The doctor roller is adjusted to give a distance of 0.08 millimeters between itself and the ink roller. It rotates to create an even thickness of ink.

The ink roller does not contact the screen [F] when not printing. However, during the printing process, the ink on the ink roller is transmitted to the print paper through holes in the screen and the master while the drum screen is held against the master by the pressure roller located under the drum.

Gear [E] has a one-way clutch to prevent the ink roller from rotating in the reverse direction when the drum turns in the reverse direction during the master eject process.

## 7.9 DRUM MASTER DETECTION: VT2300/VT2500

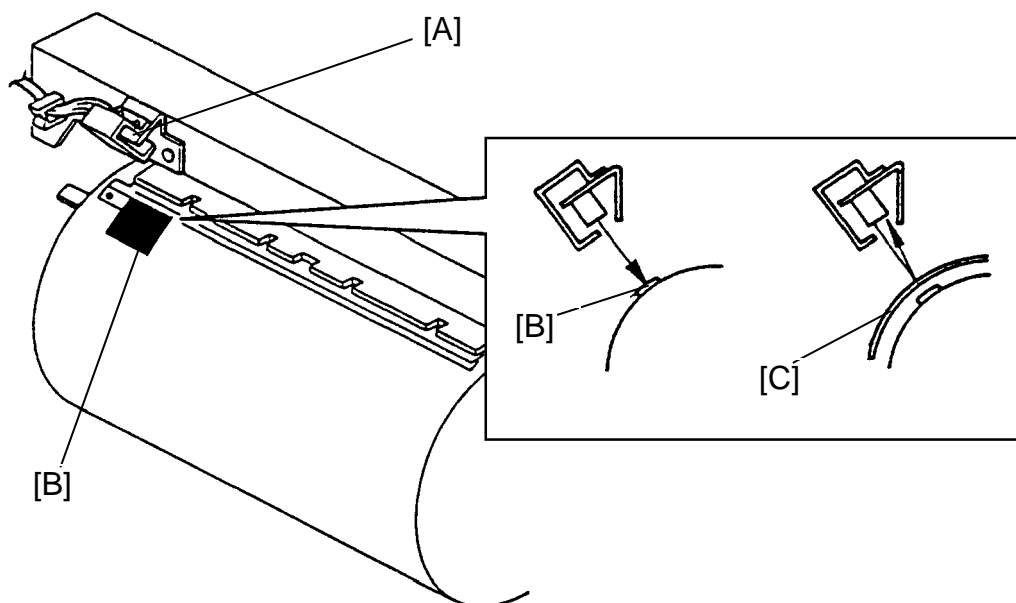

The drum master detection sensor [A] mounted on the drum rail detects whether the master is on the drum.

When there is a master on the drum, the black seal [B] is covered and the sensor detects the light reflected from the master [C]. Printing starts when the Print Start key is pressed.

When there is no master on the drum, the black seal is exposed. The black seal does not reflect light back to the sensor. The "M" indicator blinks and printing does not start when the Print Start key is pressed. The Master Making key can only be pressed after an original is set on the original table.

## 7.10 INK DETECTION

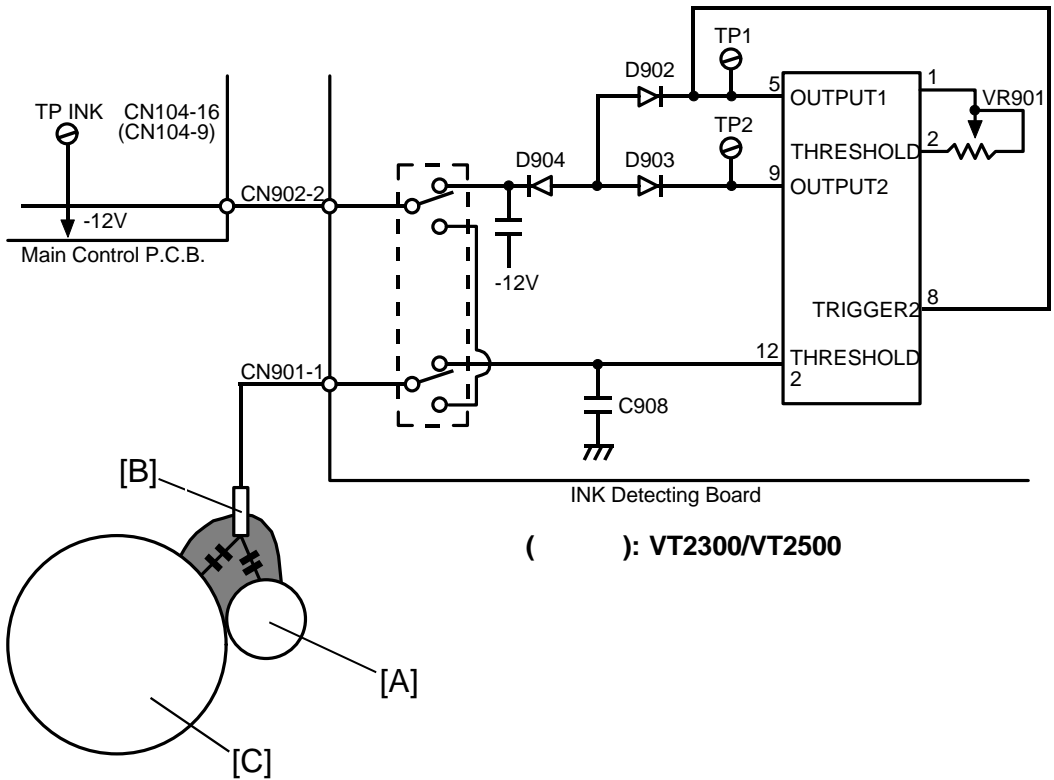

- [A]: Doctor Roller
- [B]: Detecting Pin
- [C]: Ink Roller

The ink detection circuit consists of an electrode (detecting pin), to detect the electrostatic capacity and a multivibrator. The pulse generated by the multivibrator is different when ink is present and when ink is not present. This pulse is compared to a standard pulse to detect whether or not there is ink in the drum.



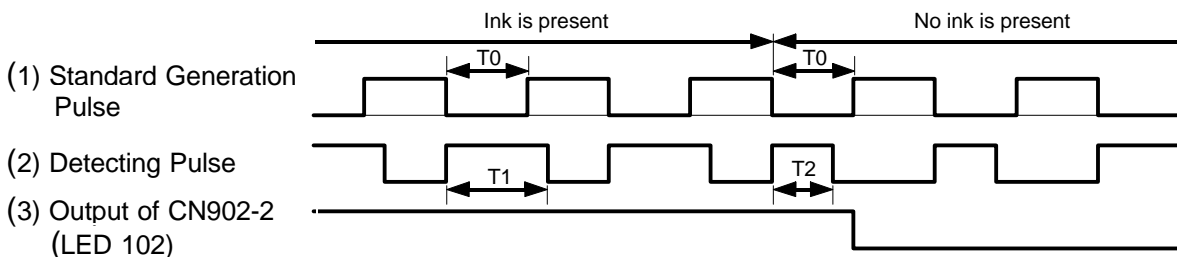

- (1) The standard pulse is output from OUTPUT 1. The pulse length ( $T_0$ ) can be adjusted by adjusting VR901.
- (2) OUTPUT 2 is the detection pulse. The time constant is determined by C908 and the ink. The detection pulse is triggered by the rising edge of the standard pulse.  
When ink is present, the electrostatic capacity increases and the pulse length ( $T_1$ ) becomes longer. On the other hand, when ink is not present, the pulse length ( $T_2$ ) becomes shorter as the electrostatic capacity decreases.
- (3) The pulse length ( $T_1$  or  $T_2$ ) is compared with the standard pulse ( $T_0$ ). When the time constant ( $T_2 =$  No ink) is shorter than the standard pulse ( $T_0$ ), the output of CN902-2 goes low.

## 7.11 ELECTRICAL TIMING

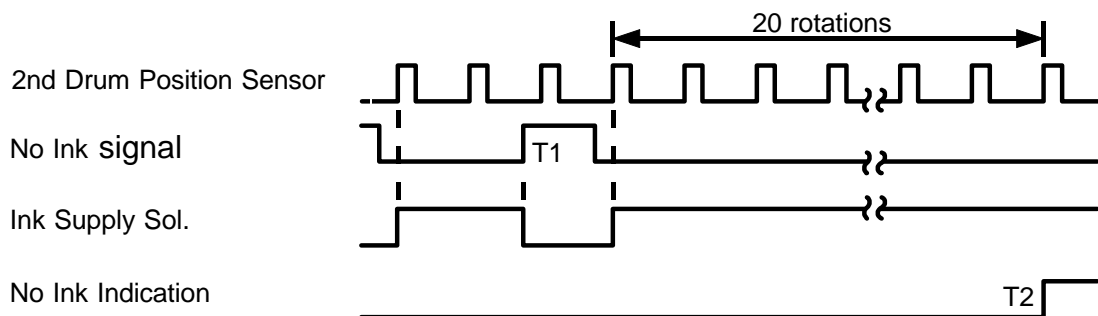

- T1:** After all the ink has been consumed and the no ink signal is HIGH, the ink supply solenoid turns on at the rising edge of the second drum position sensor signal. The ink supply solenoid turns off when the no ink signal goes HIGH.
- T2:** If after the ink supply solenoid turns on the drum turns a further 20 rotations and the no ink signal remains LOW, the No Ink indicator (D + ) blinks.
- When the "0" key and "Reset" key are pressed while the No Ink indicator (D + ) blinks, the drum turns 40 rotations.
- When the No Ink Signal goes HIGH during the 40 drum rotations, the ink supply solenoid is de-energized.

### 7.12 CIRCUIT:

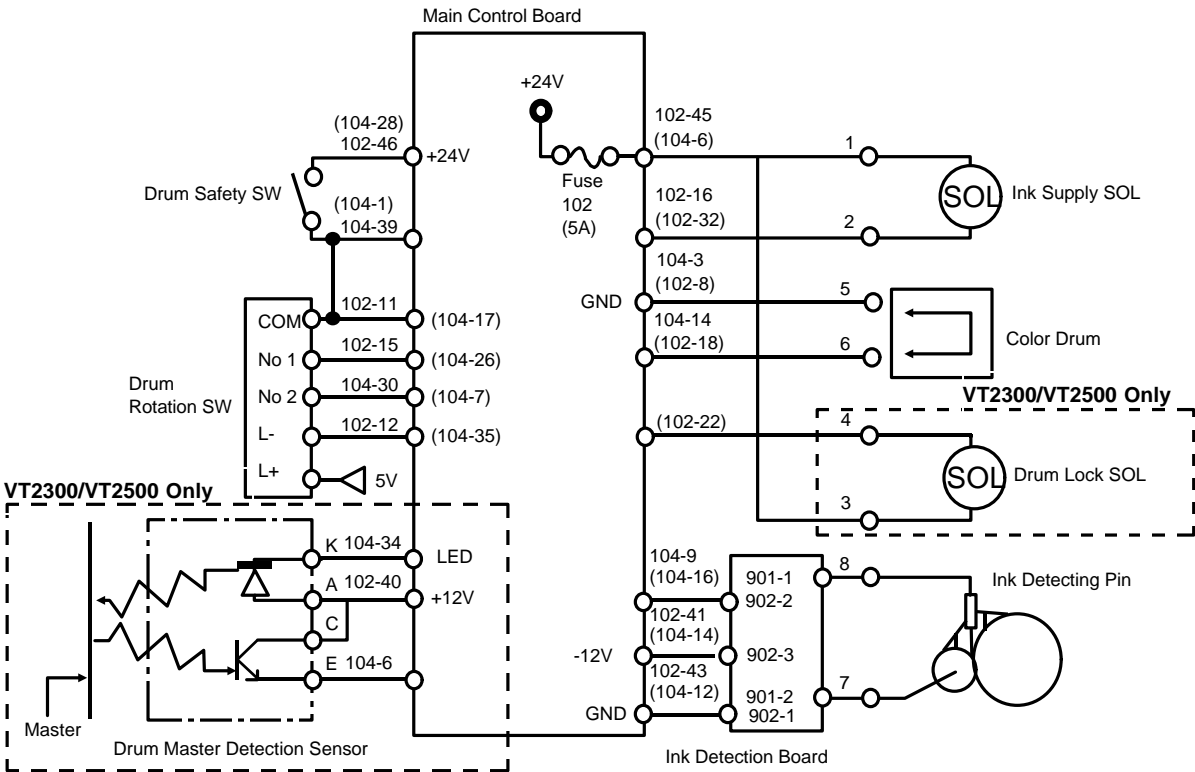

( ): VT2100/VT2130/VT2150

### 7.13 INPUT/OUTPUT:

Signal Name	I/O	Main Control PCP		Description
		CN NO	Level	
Drum Rotation SW	I	104-30 (104-7)	24V → 0V	When the drum rotation switch is pressed, the voltage at CN104-30 (CN104-7) is 0V.
Drum Master Detection (LED): VT2300/VT2500 Only	O	104-34	0V → 12V	When the main switch is turned on, the voltage at CN104-34 is 12V.
Drum Master Detection (Master): VT2300/VT2500 Only	I	104-6	0V → 0.01V	When the master is wrapped on the drum, the voltage is 0.01 V at CN104-6 and 3.5V at TP101.(When no master is on the drum, TP101 is less than 1.5V.)
Ink Supply SOL	O	102-16 (102-32)	24V → 0V	When the solenoid turns on, the voltage at CN102-16 (CN102-32) is 0V.
Drum Lock SOL: VT2300/VT2500 Only	O	102-22	24V → 0V	When the cover open indicator is displayed and the 1st drum position sensor is not interrupted, the voltage at CN102-22 is 0V.
Ink Detection	I	104-9 (104-16)	0V → -12V	When there is no ink on the ink roller, the voltage at CN104-8 is -12V.

( ): VT2100/2130/2150

## 8. IMAGE SHIFTING SECTION

### 8.1 OVERALL

The image on the printing paper can be shifted 20 millimeters either backwards or forward using the Image Shift keys on the operation panel.

The image position is adjusted by the image shifting motor which changes the paper feed timing by turning the first paper feed and second feed cams.

### 8.2 IMAGE SHIFTING MECHANISM

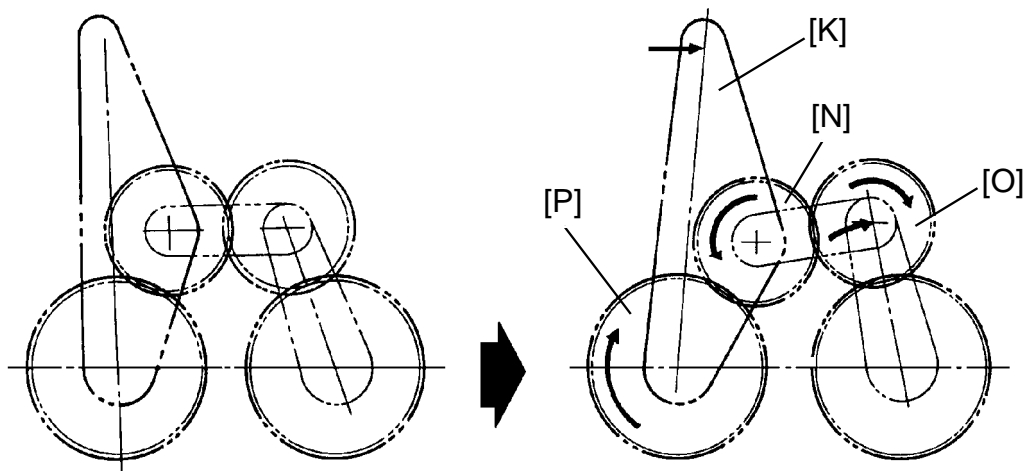

When the forward key (+key) is pressed, the image shifting motor [A] turns clockwise (in the direction of the arrow) and drives cam gear [J] clockwise through gears [B], [C], [D], [E], [F], [G] and [H] as illustrated on the next page.

The cam gear [J] has a spiral track which the lever [K] moves along. When the cam gear turns clockwise, the pin of the lever [K] moves towards the outside of the cam gear [J]. Therefore, the lever [K] moves clockwise.

The lever [K] drives the gear [O] clockwise through the gear [N] and the first paper feed and second feed cams mounted on the shaft of the gear [P] turn clockwise. As a result, the paper feed start timing is delayed compared with drum rotation timing and the image position is moved in the forward direction.

When the cam gear [J] turns, the gear [I] located behind the gear [J] turns and the encoder [M] mounted on the gear [L] turns to check the image shifting position.

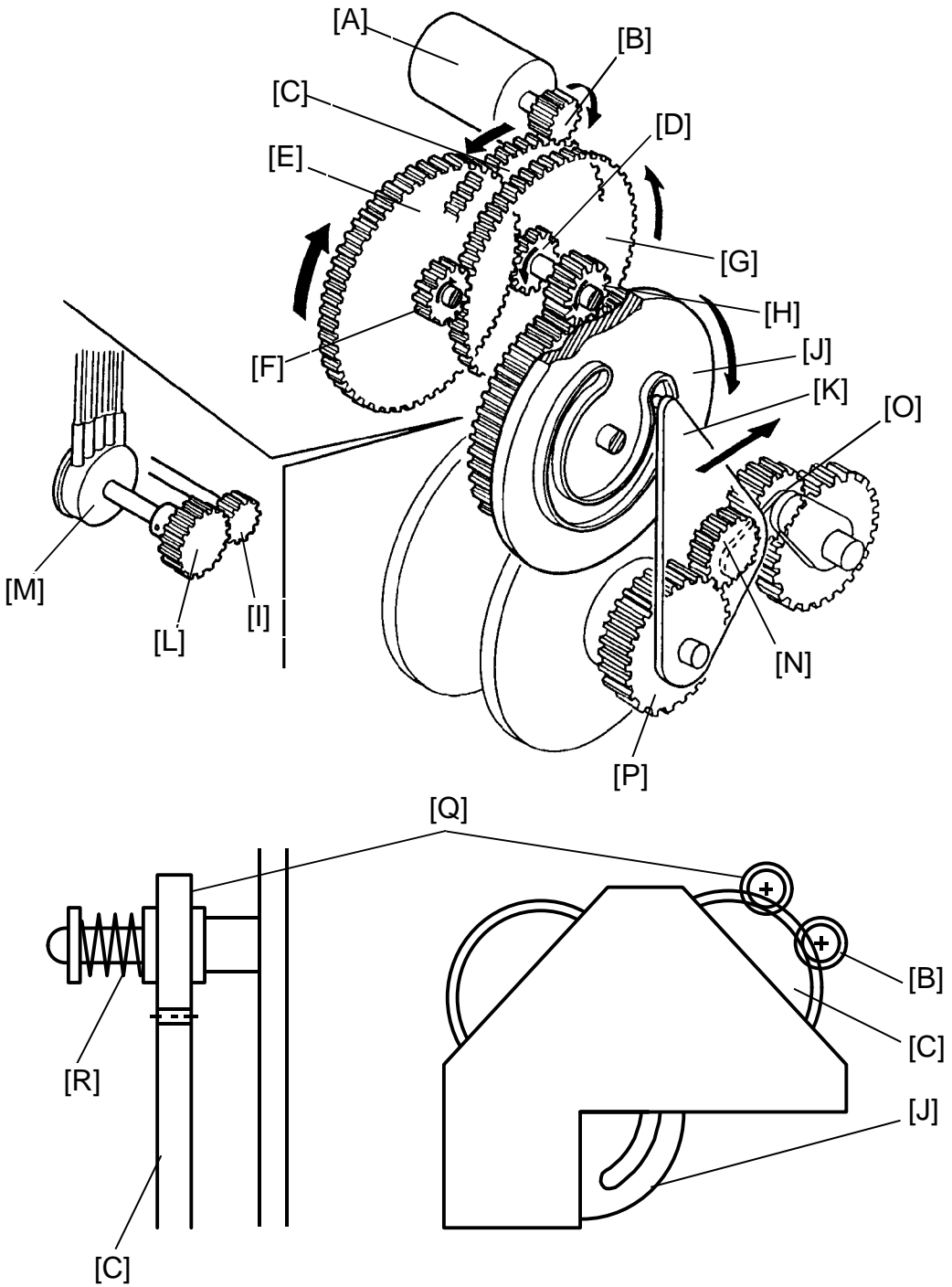

This brake mechanism prevents the print image from shifting during the printing process. The gear [Q] pressed by spring [R] is used to brake the gear [C].

### 8.3 ELECTRICAL OPERATION:

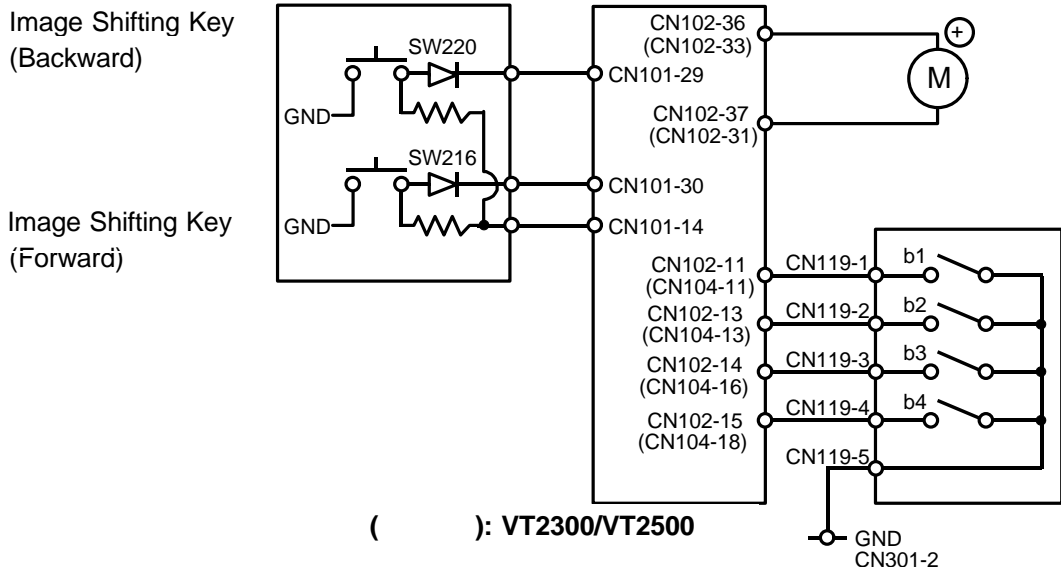

When the Image Shifting key (forward key = SW216) is pressed, CN102-37 (CN102-31) becomes 22 V and CN102-36 (CN102-33) becomes 0 V. Thus, the image shifting motor turns clockwise. (View from A as shown below.)

On the other hand, when the Image Shifting key (backward key = SW220) is pressed, CN102-36 (CN102-33) becomes 22 V and CN102-37 (CN102-31) becomes 0 V. Thus the image shifting motor turns counterclockwise. (View from A as shown below.)

To check the image position, an encoder, which converts 16 positions to 4 bit data, is used.

Position	Image Shift Area															
	(+)			0						(-)						
Hexadecimal No.	0	1	3	2	6	7	5	4	C	D	F	E	A	B	9	8
b1	0	1	1	0	0	1	1	0	0	1	1	0	0	1	1	0
b2	0	0	1	1	1	1	0	0	0	0	1	1	1	1	0	0
b3	0	0	0	0	1	1	1	1	1	1	1	1	0	0	0	0
b4	0	0	0	0	0	0	0	0	1	1	1	1	1	1	1	0

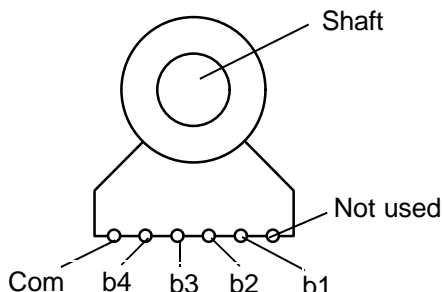

1 = Connection ON  
0 = Connection OFF

Image Shifting Motor

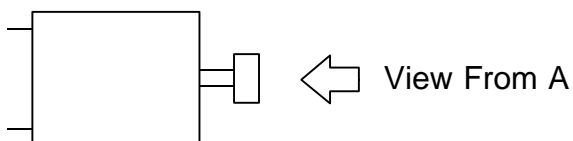

## 9. DELIVERY SECTION

### 9.1 OVERALL

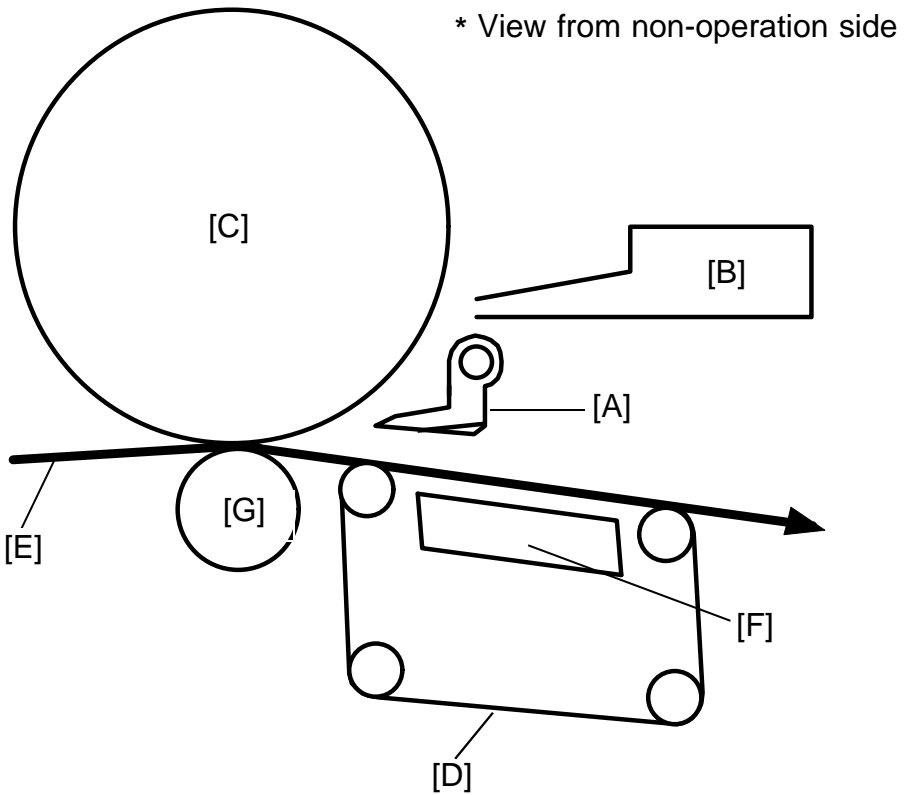

- [E]: Paper
- [F]: Vacuum Fan
- [G]: Pressure Roller

This section consists of the exit pawl [A] and air knife (blower fan) [B], which separate the paper leading edge from the drum [C], and the vacuum units [D], which deliver the separated paper to the delivery table.

## 9.2 EXIT PAWL DRIVE MECHANISM

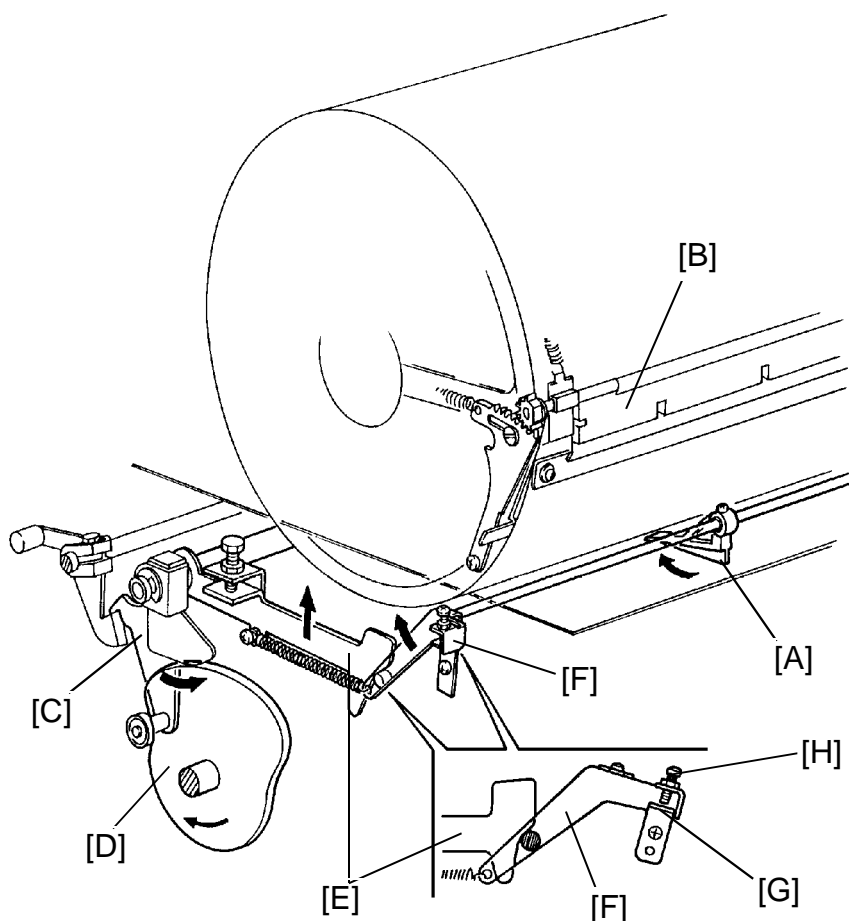

The exit pawl [A] located in the center of the drum, guides the center of the printing paper. As the master clammer [B] approaches the exit pawl, the exit pawl moves away from the drum.

When the bearing of the pressure ON/OFF cam [C] comes to the top of the pressure cam [D], the exit pawl drive cam [E] mounted on the pressure ON/OFF cam, moves up. The exit pawl lever [F] then turns clockwise along the surface of the exit pawl drive cam [E]. Therefore, the exit pawl also comes near the drum until the stopper [G] contacts the adjusting screw [H]. This keeps a small clearance between the exit pawl and the drum surface to enable the printing paper to feed to the vacuum unit.

As the pressure roller moves away from the drum, the exit pawl drive cam [E] moves down and the exit pawl lever [F] turns counterclockwise. This causes, the exit pawl to separate from the drum.

The exit pawl is held away from the drum when printing pressure is not applied.



## 9.3 VACUUM UNIT DRIVE MECHANISM

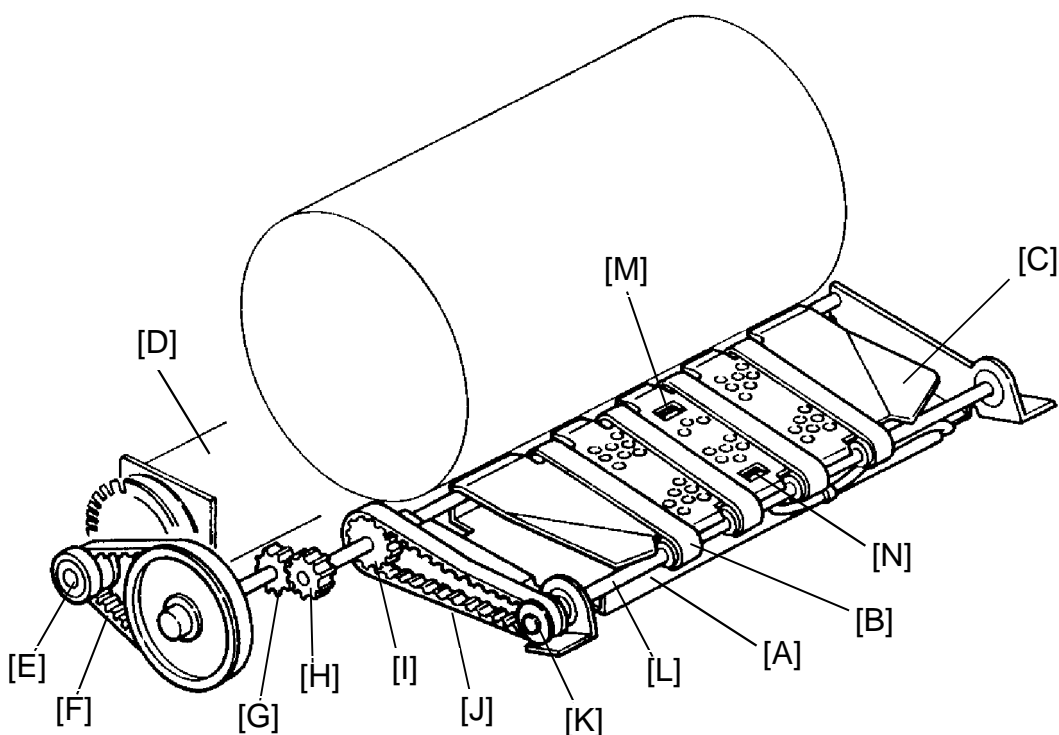

The vacuum fan [A] holds the paper against the transport belts [B]. The transport belts move the paper to the delivery table.

A fixed wing guide [C] at each end of the vacuum unit helps keep the back side of the printing paper clean.

When the main motor [D] turns on, the gear [E] mounted on the main motor shaft drives belt [F], gears [G] and [H], pulley [I], drive belt [J], pulley [K], and drive shaft [L]. This drive shaft turns the transport belts [B].

**NOTE:** The VT2100/VT2130/VT2150 use a gear instead of a timing belt [F].

The first and second paper exit sensors [M] and [N] check for paper jams. The paper exit jam check is done when printing pressure is applied and the printing pressure sensor is interrupted.

	1st Paper Exit Sensor [M]	2nd Paper Exit Sensor [N]
When 2nd Drum Position sensor is ON	On : Correct OFF:Paper Wrap	OFF:Correct ON :Delivery Miss
When 1st Drum Position Sensor is ON	----- -----	ON :Correct OFF:Paper Wrap

## 9.4 MISFEED/PAPER WRAP

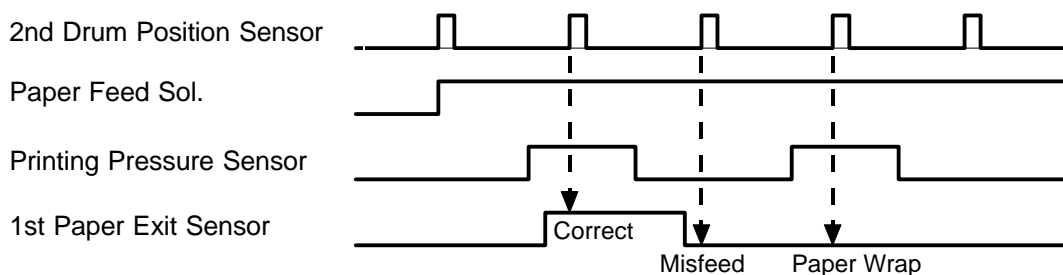

### Misfeed

If printing pressure is not applied (printing pressure sensor is interrupted) when the paper feed solenoid turns on, the Misfeed indicator blinks and the drum stops.

### Paper Wrap

If the first paper exit sensor does not turn on when the paper feed solenoid turns on, the Paper Wrap indicator blinks and the drum stops.

## 9.5 EXIT MISFEED/PAPER WRAP

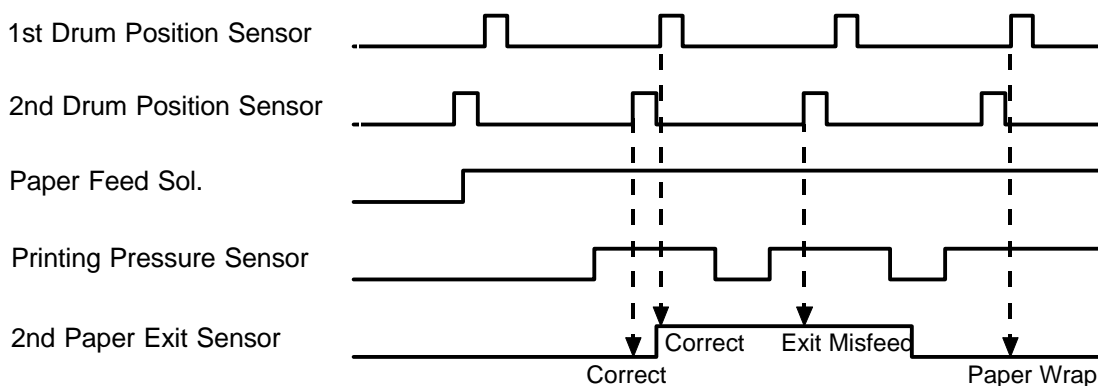

### Exit Misfeed

If the second paper exit sensor and the second drum position sensor turn on at the same time after printing pressure is applied, the Exit Misfeed indicator blinks and the drum stops.

### Paper Wrap

After printing pressure is applied, if the second paper exit sensor turns off when the first drum position sensor turns on, the Paper Wrap indicator blinks and the drum stops.

## 9.6 CIRCUIT: VT2100/VT2130/VT2150

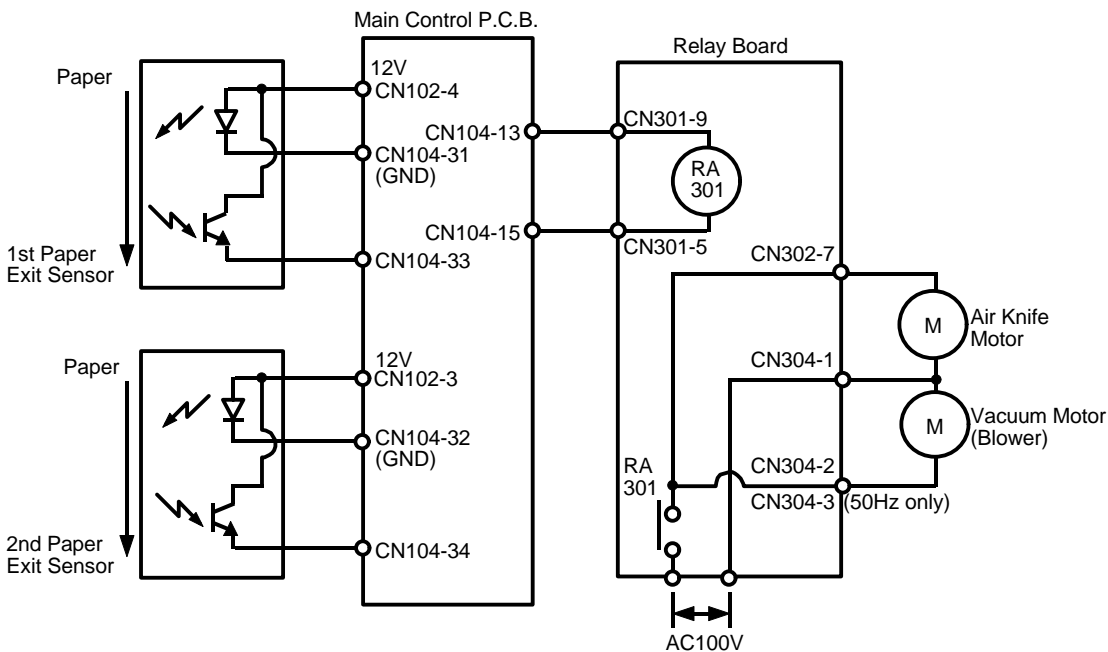

## 9.7 INPUT/OUTPUT: VT2100/VT2130/VT2150

Signal Name	I/O	Main Control PCB		Description
		CN No.	Level	
1st Paper Exit Sensor	I	CN104-33		When the paper passes, the voltage at CN104-33 is more than 3 V.
2nd Paper Exit Sensor	I	CN104-34		When the paper passes, the voltage at CN104-34 is more than 3 V.
Relay: Blower	O	CN104-13		When the air knife motor and the vacuum motor turn on, the voltage at CN104-13 is 0 V.

## 9.8 CIRCUIT: VT2300/VT2500

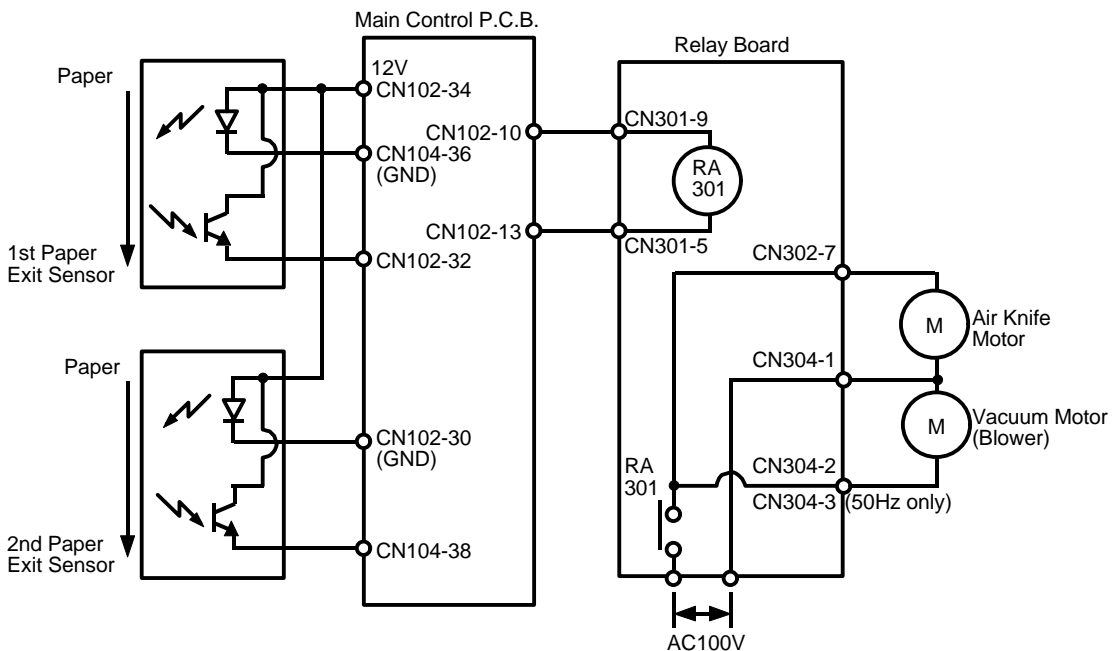

## 9.9 INPUT/OUTPUT: VT2300/VT2500

Signal Name	I/O	Main Control PCB		Description
		CN No.	Level	
1st Paper Exit Sensor	I	CN102-32		When the paper passes, the voltage at CN102-32 is more than 3 V.
2nd Paper Exit Sensor	I	CN104-38		When the paper passes, the voltage at CN104-38 is more than 3 V.
Relay: Blower	O	CN102-10		When the air knife motor and the vacuum motor turn on, the voltage at CN102-10 is 0 V.

## 9.10 ELECTRICAL TIMING:

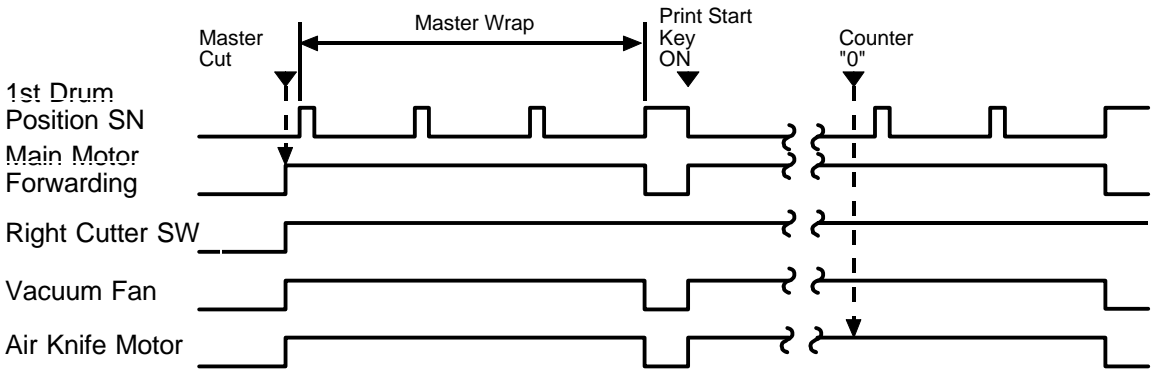

- T1: After the master is cut and the right cutter switch turns on, the main motor starts rotating. At the same time, the air knife motor and the vacuum fan also turn on and stay on until the first drum position sensor turns on 4 times.
- T2: When the Print Start key is pressed, the main motor starts rotating and the air knife motor and the vacuum fan also turn on. Then, when the counter indicates "0", the main motors turn off after the first drum position sensor turns on 4 times.

## 10. INDICATORS/KEYS/PROGRAMS: VT2300/VT2500

---

### 10.1 CHECK PAPER SIZE/DIRECTION INDICATOR

When an enlargement ratio (A4: 115%, 122%, or 141% LT: 115%, 127%, or 141%) is selected with the Reduce/Enlarge key, the Check Paper Size/Direction indicator lights. This indicator turns off when the Master Making key, Print Start key, or Proof key is pressed and full size mode or reduction mode is selected.

All keys remain accessible after the Check Paper Size/Direction indicator lights. This indicator simply reminds the customer to check the size and direction of the paper set on the paper table.

### 10.2 REDUCE/ENLARGE KEY

The Reduce/Enlarge key can be used when the machine stops. The reproduction ratio changes as shown below.

A4 version : 71%→82%→93%→115%→122%→141%

LT version : 64%→75%→93%→115%→122%→141%

### 10.3 SKIP PAPER FEED SWITCH

The paper feed interval can be set to allow time for the user to remove prints. This interval can be adjusted with the Skip Paper Feed switch. The three following steps are available:

- Standard (normal feeding)
- 1/3 rotation (one sheet fed every three drum rotations)
- 1/5 rotation (one sheet fed every five drum rotations)

This function can also be used in Proof Mode.

If the Stop key is pressed before the copier feeds out a print during the 1/3 or 1/5 step interval, the copier returns to the normal feed interval and a print is fed out soon after the Start key is pressed.

## 10.4 COMBINE 2 ORIGINALS

The length of the original in Combine 2 Originals mode is limited according to the printing paper size and magnification ratio. When the original is too long, Combine 2 Original mode is automatically canceled and only the first original is made.

The following table lists the optimum magnification ratio for each paper size/original size combination in Combine 2 Originals mode.

### A4 Version :

Paper Size	Master Making Length		Acceptable Original Size Ratios in Combine 2 Originals mode				
	100% or more	93% or less	A4 Sideways	B5 Sideways	A5 Sideways	B6 Sideways	A6 Sideways
A5 sideways	172mm	203.1 mm	X	X	71%	82%	100%
B5 lengthwise	247mm	251.3 mm	X	71%	82%	100%	122%
A4 lengthwise	287mm	291.1 mm	71%	82%	100%	115% (122%)	141%
B4 lengthwise	354mm	354 mm	82%	100%	122%	141%	*141%

### LT Version:

Paper Size	Master Making Length		Acceptable Original Size Ratios in Combine 2 Originals mode	
	100% or more	less than 93%	LT Sideways	HLT Sideways
HLT lengthwise	205.9 mm	205.9 mm	X	*64%
LT lengthwise	269.4 mm	269.4 mm	64%	100%
LG lengthwise	345.6 mm	345.6 mm	*75%	127%

X : Combine 2 Originals mode is canceled.

When the values given in the above table are exceeded, Combine 2 Originals mode is also canceled.

\* : A black area is mode.

## 10.5 MEMORY/CLASS KEY

The Memory/Class switch selects Memory or Class mode.

When Memory mode is selected (Memory indicator lights), Up to 15 prints can be input. Press the Master Making key after returning the memory number to "1".

When Class mode is selected (Class indicator lights), the number of prints for up to 20 groups can be input.

## 10.6 TRIAL PRINTS

Two trial printing sheets can be fed out by holding down the Master Making key and the Speed key  .

Only one trial printing sheet is fed out when just the Master Making key is pressed.

## 10.7 CLEAR MODES KEY

The Clear Modes key can be used after the machine stops. All previously entered settings and modes are cleared by the Clear Modes key. The normal settings and modes are displayed on the operation panel as follows:

Make-up Mode	OFF
Combine 2 Originals	OFF
Image Mode	Line
Printing Density	Standard
Magnification Ratio	100%
Auto Cycle Mode	OFF
Printing Speed	3
Image Position	0 (Previous setting remains when the Cover Open indicator lights.)
Counter Indicator	0
Memory Indicator (Class Indicator)	1



## 10.8 INITIAL CHECK

When the main switch is turned on, the CPU checks the ON/OFF status of the sensors listed below. If a sensor is ON, the letter on the Jam indicator corresponding to the sensor blinks:

Master Eject Sensor.....	F
Master Buckle Sensor.....	C
2nd Original Sensor .....	A
Original Registration Sensor .....	A
1st/2nd Paper Exit Sensor .....	G
Printing Pressure Sensor .....	E

## 10.9 MAIN MOTOR SOFT START

The main motor turns at 60 rpm for the first print (not trial print) made from a new master. The printing speed then gradually increases with each rotation until the standard printing speed is reached.

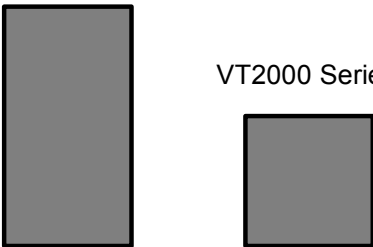

# 11. DIFFERENCES BETWEEN SS900 SERIES AND VT 2000 SERIES

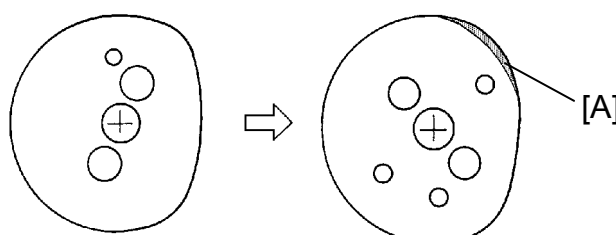
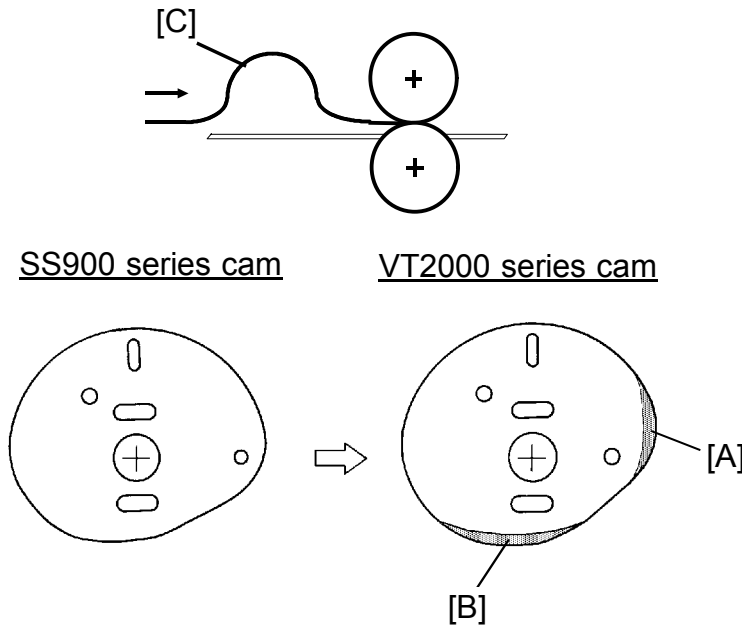
No.	Item	Remarks
1	Thermal Head	<p>The heating elements used in the VT2000 series thermal head are smaller than those used on the SS900 series. This reduces ink set-off on the back sides of copies.</p> <div style="text-align: center;"> <p>SS900 Series</p>  <p>VT2000 Series</p> </div>
2	Thermal Head Drive Board	The thermal head drive voltage has been decreased from 24V to 16V because the smaller heating elements in the thermal head require less power.
3	Power Supply Board	<p>The power supply board has been modified to output 16V to drive the thermal head.</p> <p>An ON/OFF switching circuit for the thermal head drive voltage (VHD) has been added to the power supply board.</p>
4	Exterior	The design of the front cover and the model name printed on the cover have been changed. This was done for marketing reasons and to ensure that the users do not confuse the VT2000 series with the 900 series and use the wrong master type. (The VT2000 master is more sensitive.)
5	Image Processing Board	The VT2500 make-up control board has been eliminated because the VT2500 image processing board performs the Make-up function.
6	Main Harness	A VHD ON/OFF line has been added to the main harness.
7	Drum Master Sensor	The drum master sensor has been changed to stabilize the sensor sensitivity.

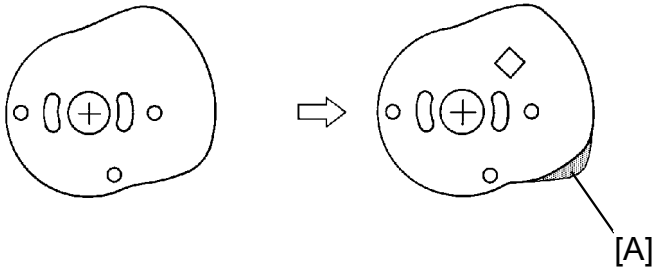
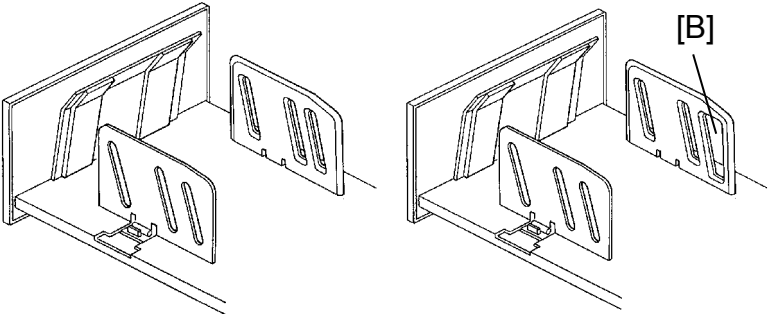
No.	Item	Remarks
8	Paper Feed Roller Cam	<p>The paper feed roller cam has been slightly modified as shown to reduce the paper speed to 55% that of the SS900 series. (Extended outward at point [A].) This reduces the noise caused when the paper leading edge strikes the second feed roller.</p> <p style="text-align: center;"> <u>SS900 series cam</u>      <u>VT2000 series cam</u> </p> 
9	Second Feed Roller Cam	<p>The second feed cam has been modified slightly as shown to reduce the speed of the second feed roller to 40% that of the SS900 series. (Extended outward at point [A], moved in at point [B].) This reduces the noise caused when the second feed rollers turn and the paper [C] snaps as it is pulled taut.</p>  <p style="text-align: center;"> <u>SS900 series cam</u>      <u>VT2000 series cam</u> </p>

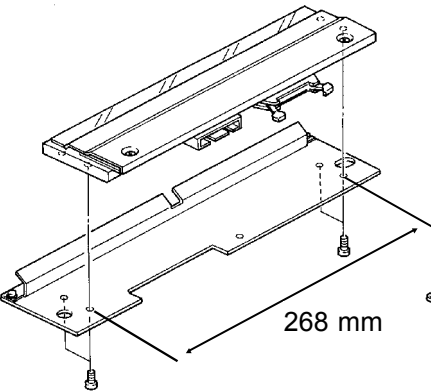
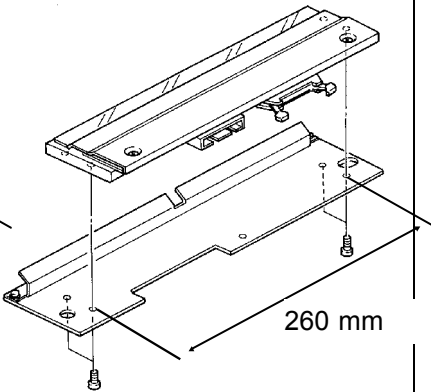
No.	Item	Remarks
10	Pressure Cam	<p>The shape of the VT2000 pressure cam has been modified slightly as shown to decrease the pressure roller speed to 70% that of the SS900 series. (A portion at point [A] has been shaved off.) This reduces the noise caused when the pressure roller moves against the drum.</p> <p style="text-align: center;"><u>SS900 series cam</u>      <u>VT2000 series cam</u></p> 
11	Rear Paper Delivery Side Plate	<p>One of the air slots [B] cut in the rear paper delivery side plate has been enlarged so that tape strips from the optional tape dispenser can be inserted through it.</p> <p style="text-align: center;"><u>SS900 series</u>      <u>VT2000 series</u></p> 
12	Main Control Board	<p>An ON/OFF control circuit for the thermal head drive voltage (VHD) has been added to the main control board.</p> <p>The drum master detection circuit on the main control board has been modified to accommodate the new drum master sensor.</p>

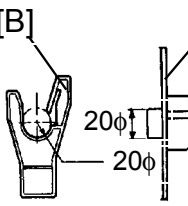
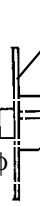
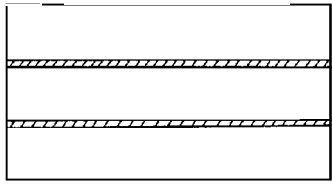
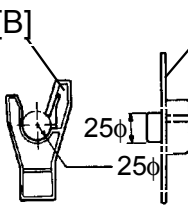
No.	Item	Remarks																												
13	Printing Speed	<p>The 40 cpm print speed at each step has been eliminated on the VT2000 series. This reduces ink set-off, which is most likely to occur at low printing speeds.</p> <table border="0" data-bbox="284 309 1100 511"> <tr> <td></td> <td style="text-align: center;"><u>SS900 Series</u></td> <td style="text-align: center;"><u>VT2000 Series</u></td> </tr> <tr> <td>Step 1:</td> <td>40 sheets/min.</td> <td>60 sheets/min.</td> </tr> <tr> <td>Step 2:</td> <td>60 sheets/min.</td> <td>75 sheets/min.</td> </tr> <tr> <td>Step 3:</td> <td>80 sheets/min.</td> <td>90 sheets/min.</td> </tr> <tr> <td>Step 4:</td> <td>100 sheets/min.</td> <td>105 sheets/min.</td> </tr> <tr> <td>Step 5:</td> <td>120 sheets/min.</td> <td>120 sheets/min.</td> </tr> </table> <p>When the Master Making key is pressed, the print speed gradually increases until it reaches the set speed.</p> <table border="1" data-bbox="319 662 1068 746"> <thead> <tr> <th></th> <th>Trial Print</th> <th>1st Print</th> <th>2nd Print</th> <th>3rd Print</th> </tr> </thead> <tbody> <tr> <td>SS935/955:</td> <td>10 rpm</td> <td>40 xrpm</td> <td>60 rpm</td> <td>80 rpm</td> </tr> </tbody> </table>		<u>SS900 Series</u>	<u>VT2000 Series</u>	Step 1:	40 sheets/min.	60 sheets/min.	Step 2:	60 sheets/min.	75 sheets/min.	Step 3:	80 sheets/min.	90 sheets/min.	Step 4:	100 sheets/min.	105 sheets/min.	Step 5:	120 sheets/min.	120 sheets/min.		Trial Print	1st Print	2nd Print	3rd Print	SS935/955:	10 rpm	40 xrpm	60 rpm	80 rpm
	<u>SS900 Series</u>	<u>VT2000 Series</u>																												
Step 1:	40 sheets/min.	60 sheets/min.																												
Step 2:	60 sheets/min.	75 sheets/min.																												
Step 3:	80 sheets/min.	90 sheets/min.																												
Step 4:	100 sheets/min.	105 sheets/min.																												
Step 5:	120 sheets/min.	120 sheets/min.																												
	Trial Print	1st Print	2nd Print	3rd Print																										
SS935/955:	10 rpm	40 xrpm	60 rpm	80 rpm																										
14	Thermal Head Mounting Plate	<p>To prevent service personnel from mistakenly installing the SS900 thermal head on VT2000 series machines and vice versa, the distance between the screw holes on each mounting plate is different.</p> <div style="display: flex; justify-content: space-around;"> <div style="text-align: center;"> <p><u>SS900 series</u></p>  <p>268 mm</p> </div> <div style="text-align: center;"> <p><u>VT2000 series</u></p>  <p>260 mm</p> </div> </div>																												

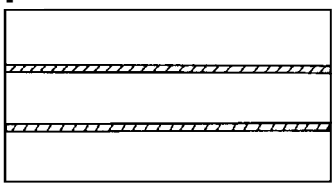
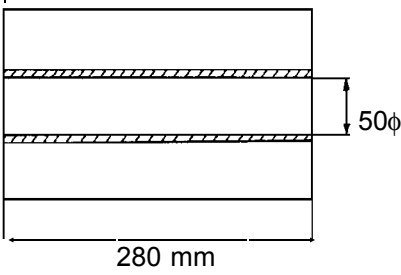
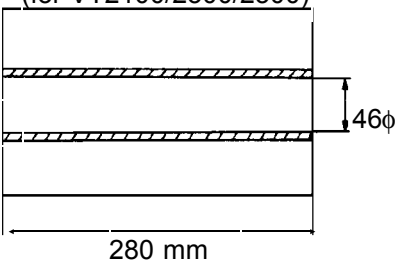
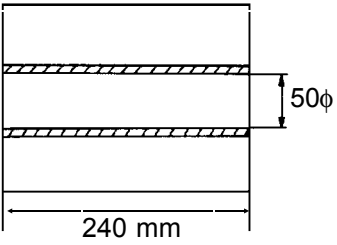
No.	Item	Remarks
15	Master Spool/ Holder	<p>To prevent users from installing SS900 masters on VT2000 series machines, the diameter of each master spool [A] and master spool holder [B] has been changed as follows:</p> <div style="display: flex; flex-direction: column; align-items: center;"> <div style="display: flex; align-items: center; margin-bottom: 20px;"> <div style="text-align: center; margin-right: 20px;">  <p>[B] 20φ</p> </div> <div style="text-align: center; margin-right: 20px;">  <p>[A] 20φ</p> </div> <div style="text-align: center;"> <p><b>SS900 series</b></p>  <p>50φ</p> </div> </div> <div style="display: flex; align-items: center; margin-bottom: 20px;"> <div style="text-align: center; margin-right: 20px;">  <p>[B] 25φ</p> </div> <div style="text-align: center; margin-right: 20px;">  <p>[A] 25φ</p> </div> <div style="text-align: center;"> <p><b>VT2000 series</b></p>  <p>46φ</p> </div> </div> <p><b>NOTE:</b> The VT2130/2150 spool is the same diameter as the SS900 spool; however, the type 900 master is too wide to fit on the VT2130/2150 spool holder.</p> <div style="display: flex; justify-content: space-around; width: 100%;"> <div style="text-align: center;"> <p>Master Type 900</p>  <p>50φ 280 mm</p> </div> <div style="text-align: center;"> <p>Master Type VT-M (for VT2100/2300/2500)</p>  <p>46φ 280 mm</p> </div> </div> <div style="text-align: center; margin-top: 20px;"> <p>Master Type VT-S (for VT2130/2150)</p>  <p>50φ 240 mm</p> </div> </div>

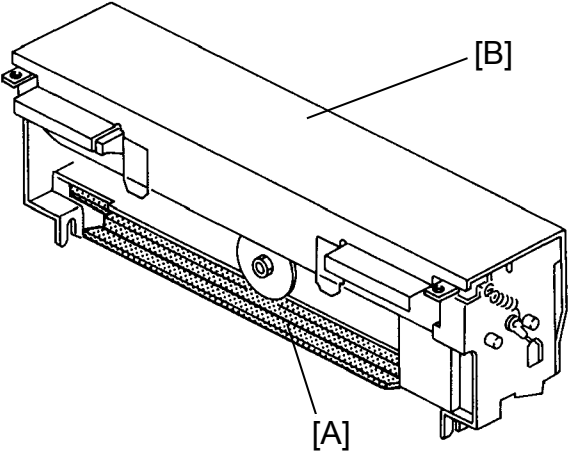
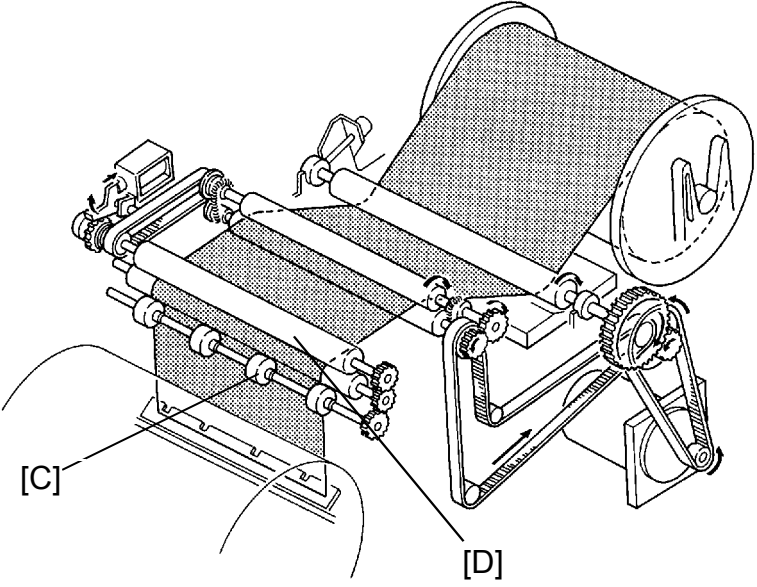
No.	Item	Remarks
16	Cutter Section	<p>A guard [A] has been mounted on the cutter unit [B] to prevent contact with the cutter edge (sharp) during cutter unit removal or installation.</p> 
17	Master Feed Unit	<p>Counter rollers [C] have been added to prevent new masters from creasing as they are being fed through the master reverse section. Also, the reverse roller [D] has been modified as shown.</p> 

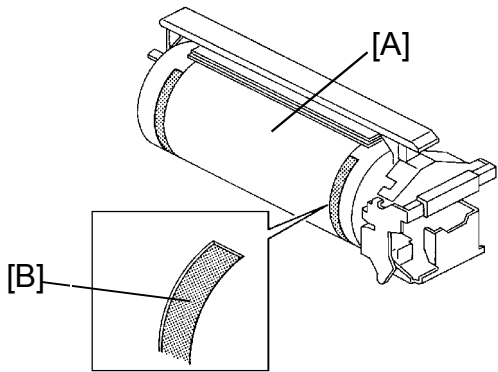
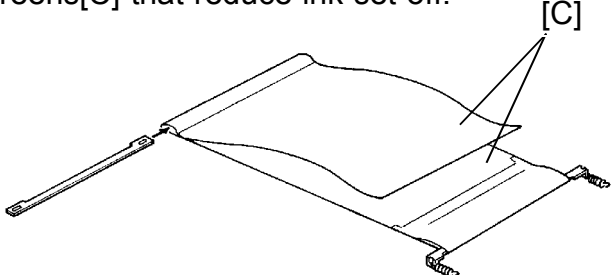
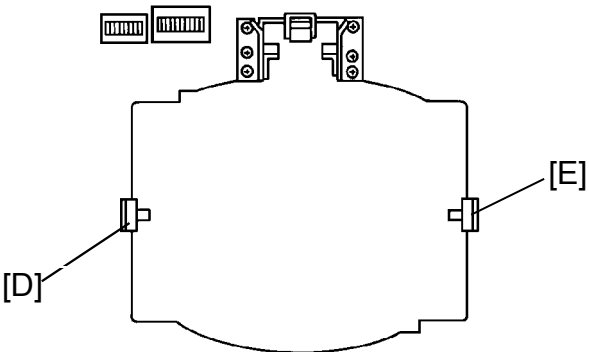
No.	Item	Remarks												
18	Drum Unit	<p data-bbox="281 186 1061 313">Both ends of the metal screen [A] pass through a half etching process. The half etch area [B] is thinner than the other areas. This improves the outer portion of the copy image.</p>  <p data-bbox="281 735 929 803">The outer drum screen consists of two tetron screens[C] that reduce ink set-off.</p>  <p data-bbox="281 1087 1073 1185">The diameter of the left drum lock pin [D] and the right drum lock pin [E] is different for each drum type as follows:</p>  <table border="1" data-bbox="384 1607 1073 1764"> <thead> <tr> <th>Color Drum</th> <th>Left [D]</th> <th>Right [E]</th> </tr> </thead> <tbody> <tr> <td>VT2000-M: (B4 Size)</td> <td>8φ</td> <td>8φ</td> </tr> <tr> <td>VT2000-S: (A4 Size)</td> <td>10φ</td> <td>7.6φ</td> </tr> <tr> <td>VT2000-LG: (LG Size)</td> <td>10φ</td> <td>7.6φ</td> </tr> </tbody> </table>	Color Drum	Left [D]	Right [E]	VT2000-M: (B4 Size)	8φ	8φ	VT2000-S: (A4 Size)	10φ	7.6φ	VT2000-LG: (LG Size)	10φ	7.6φ
Color Drum	Left [D]	Right [E]												
VT2000-M: (B4 Size)	8φ	8φ												
VT2000-S: (A4 Size)	10φ	7.6φ												
VT2000-LG: (LG Size)	10φ	7.6φ												

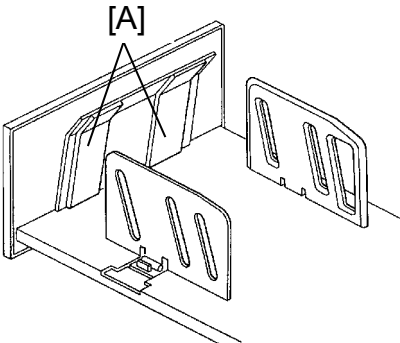
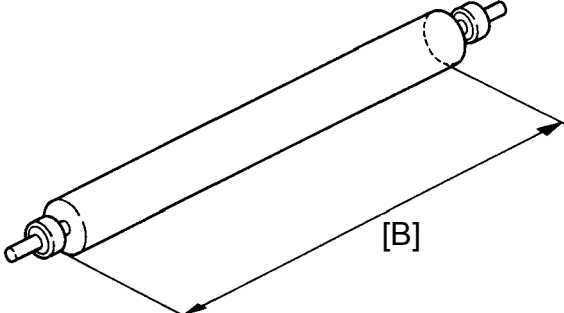
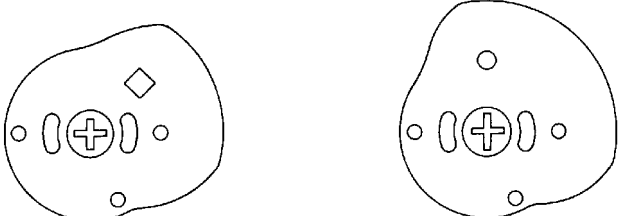

No.	Item	Remarks		
19	Paper Delivery End Plate	<p>The sponge cushions [A] that were affixed to the paper delivery end plate have been removed to prevent paper sheets from bouncing back when they strike the paper delivery end plate.</p> 		
20	Pressure Roller	<p>Two different sizes of pressure rollers are used because the printing area in the horizontal direction [B] on the VT2130/2150 machines is narrower.</p> <p>B4 size (VT2100/2300/2500): 292 mm A4/LG size (VT2130/2150): 226 mm</p> 		
21	Pressure Cam	<p>Two different types of pressure cams are used because the printing area (feed direction) of A4 copies on the VT2150 is smaller.</p> <table border="0" data-bbox="330 1381 1013 1460"> <tr> <td data-bbox="330 1381 655 1460">B4/LG Size Pressure Cam (VT2100/2130/2300/2500)</td> <td data-bbox="733 1381 1013 1460">A4 Size Pressure Cam (VT2150)</td> </tr> </table> 	B4/LG Size Pressure Cam (VT2100/2130/2300/2500)	A4 Size Pressure Cam (VT2150)
B4/LG Size Pressure Cam (VT2100/2130/2300/2500)	A4 Size Pressure Cam (VT2150)			

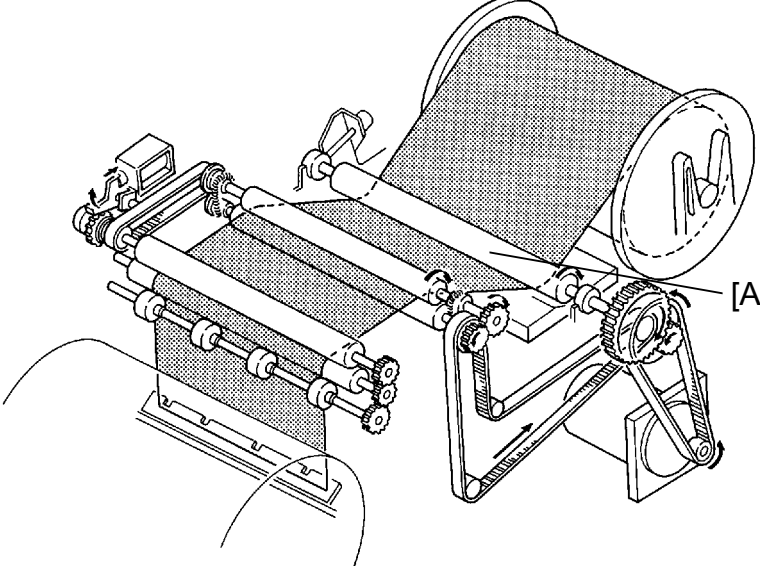
No.	Item	Remarks
22	Platen Roller	<p>The platen roller [A] has been changed to an electrically conductive type to prevent the master from wrapping around the platen roller.</p> 

# SECTION 3

# INSTALLATION

# 1. INSTALLATION REQUIREMENTS

The installation location should be carefully chosen because the environmental conditions greatly affect the performance of a machine.

## 1.1 OPTIMUM ENVIRONMENTAL CONDITIONS:

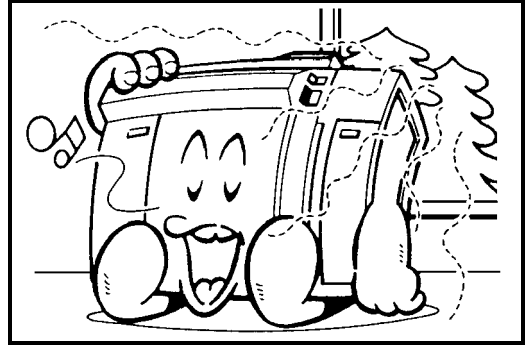
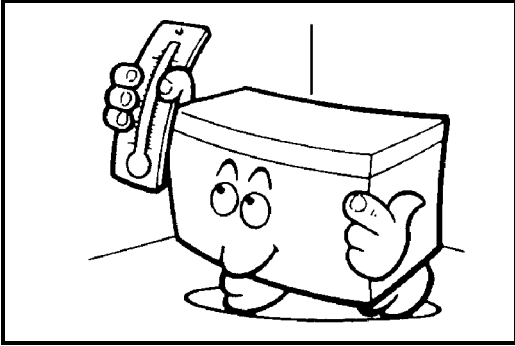

Temperature — 10 to 30°C  
(50 to 86°F)  
Humidity — 20 to 90 % RH

Well-ventilated and wide room.  
Minimum ventilation:  
air turnover 3 times / hour

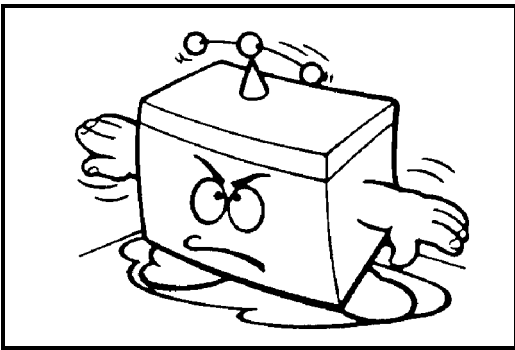

On a strong and level base.

The machine must be level within 5 mm (13/64") both front to rear and left to right.

## 1.2 ENVIRONMENTS TO AVOID:

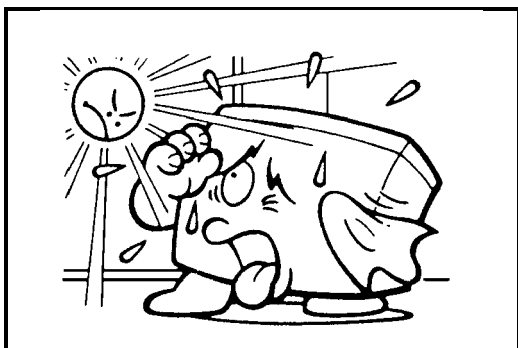

Location exposed to direct sun-light or strong light (more than 1,500 lux).

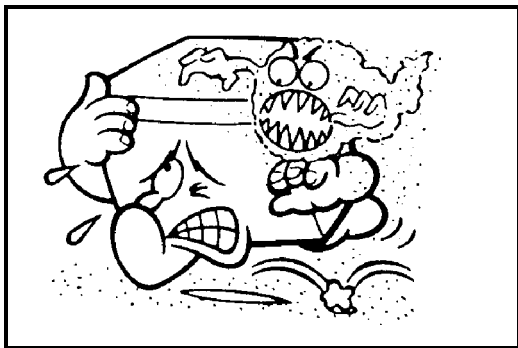

Dusty areas.

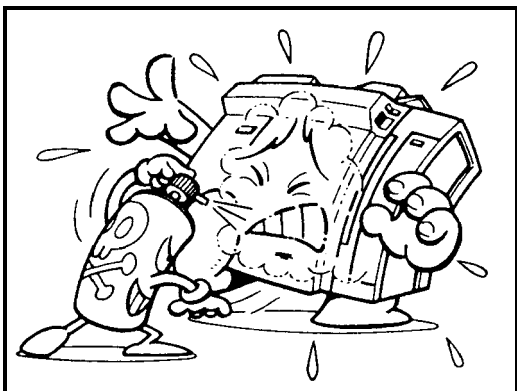

Areas with corrosive gases.

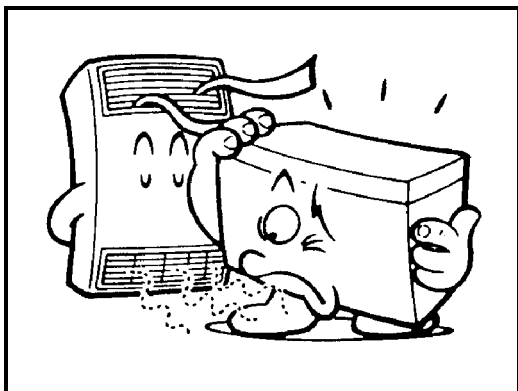

Locations directly exposed to cool air from an air conditioner or to reflected heat from a space heater. (Sudden temperature changes from low to high or vice versa may cause condensation within the machine.)

## 1.3 GROUND:

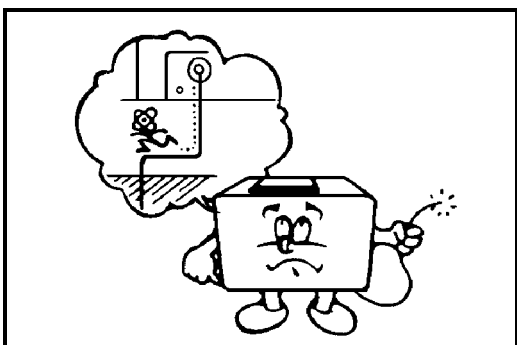

Be sure to ground the machine. Never connect the ground line to gas pipes.

## 1.4 POWER CONNECTION:

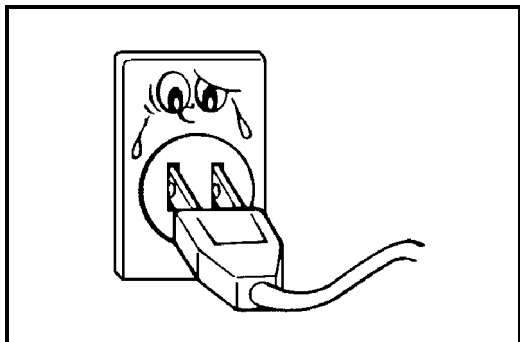

Securely connect the power cord to a power source.

- a) 110V, 60 Hz: More than 6.0A
- b) 120V, 60Hz: More than 5.5A
- c) 220V 240V, 50Hz: More than 2.7A

Make sure the plug is firmly inserted in the outlet.

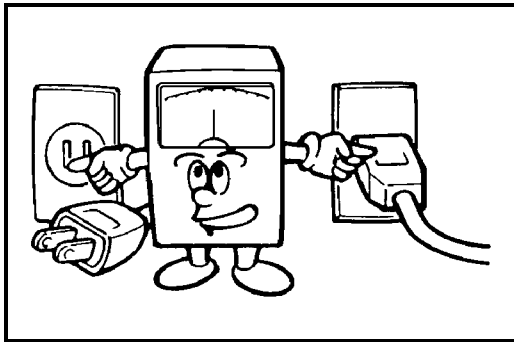

Voltage must not fluctuate more than 10%.

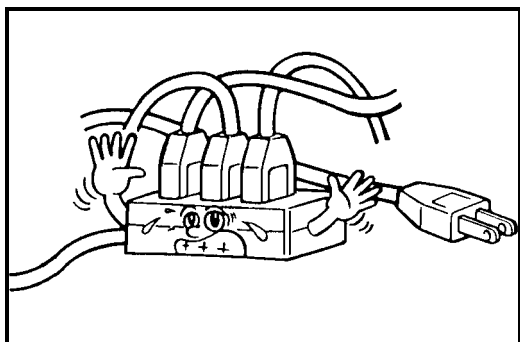

Avoid multiwiring.

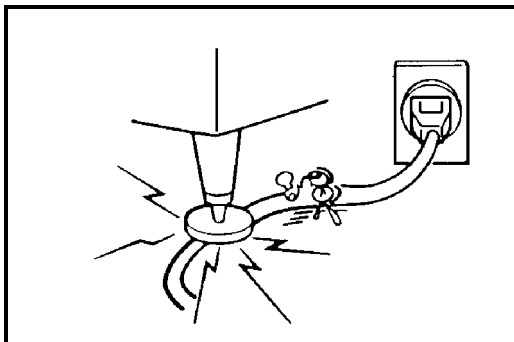

Do not pinch the power cord.

### 1.5 ACCESS TO MACHINE:

Place the machine near a power source, providing clearance as shown below.

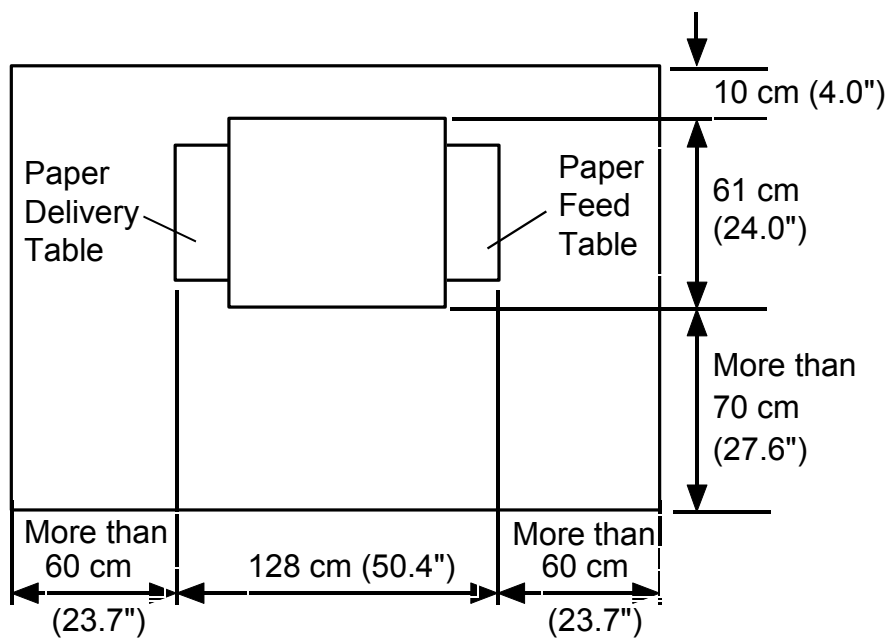

## 2. VT2300/2500 INSTALLATION PROCEDURE

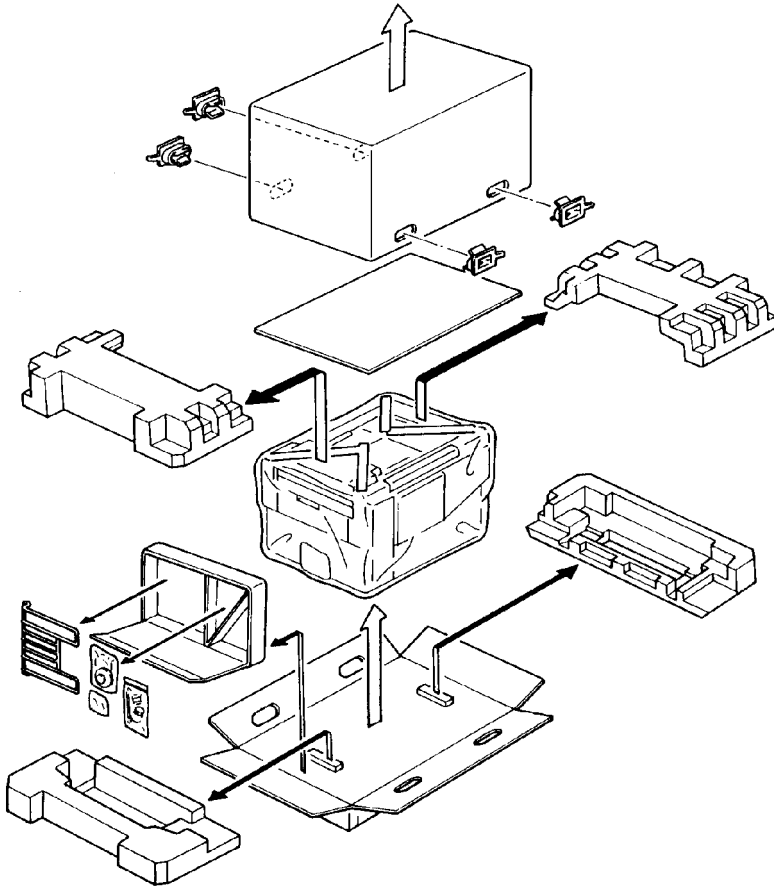

1. Make sure that you have all the accessories listed below.

(1) Original Exit Tray .....	1
(2) Right Tray Bracket .....	1
Left Tray Bracket .....	1
(3) Fixing Screws.....	2
(4) Master Spools .....	2
(5) Thermal Head Cleaner .....	1
(6) Operating Instructions (USA and Asia Version Only).....	1
(7) Operating Guide (USA and Asia Version Only).....	1
(8) NECR.....	1
(9) Installation Procedure (English).....	1
(10) Noise Absorber .....	2
(11) Background Pattern Sheet (VT2500 only).....	1



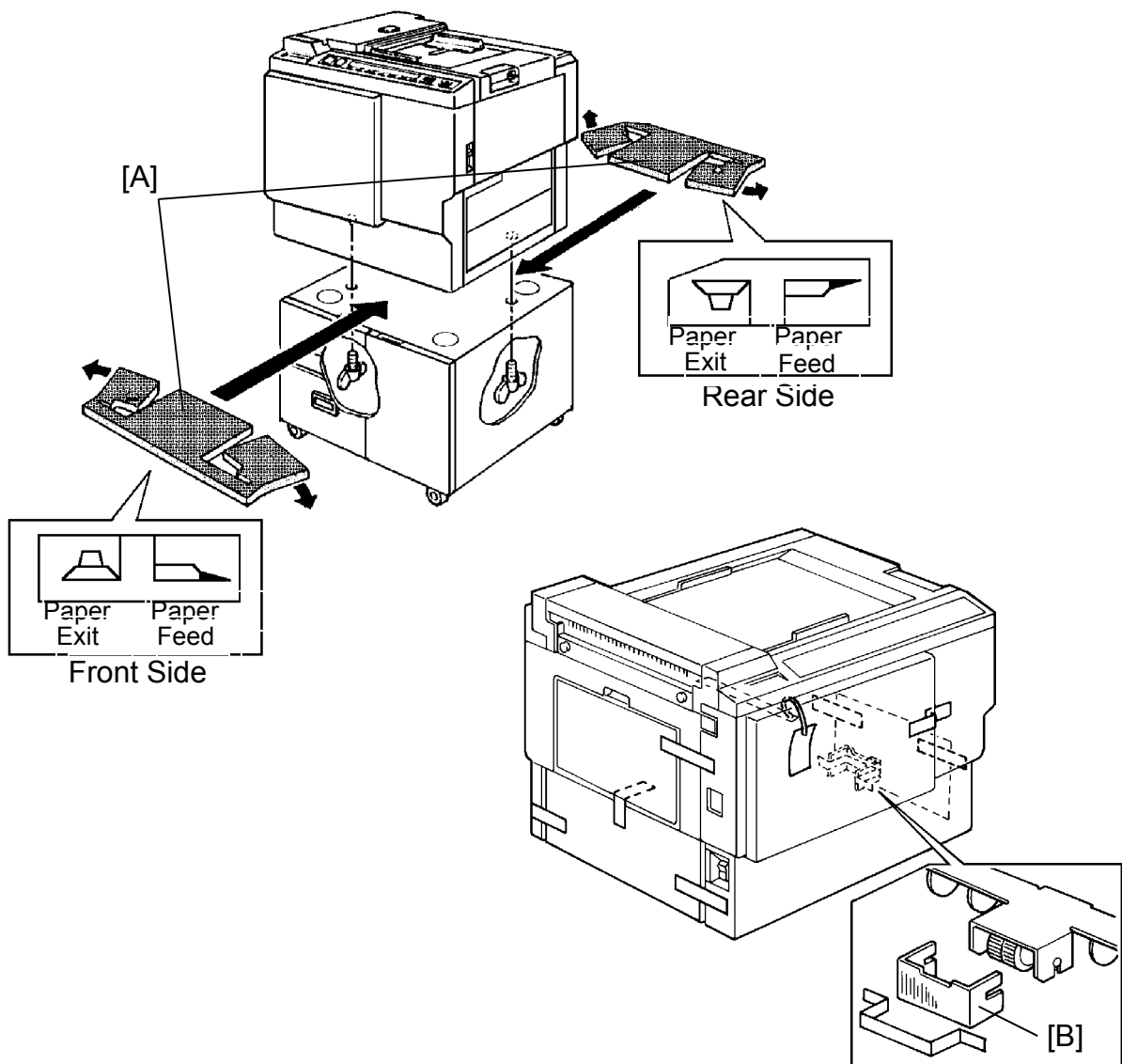

2. Place two noise absorbers on the optional table.

NOTE: Make sure that the noise absorbers are positioned on the table at the locations shown in the above figure.

3. Mount the machine on the optional table (2 screws--packed with table).

4. Remove the tape and string securing the covers and units as shown above.

a. Open the paper feed tray. Then remove the cushion plate [B] from the paper feed roller section.

b. Open the master delivery unit. Then remove the tape securing the paper delivery guide plate.

5. Remove the protective sheet [A] from the drum unit.

- a. Open the front door.
- b. Take out the drum unit.
- c. Remove the protective sheet from the master clamper.
- d. Reinstall the drum unit in the machine.

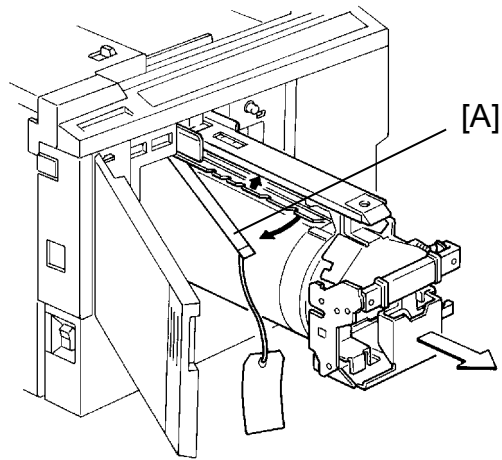

6. Install the original exit tray [B].

- a. Hook the right and left tray brackets on the stepped screws.
- b. Set the original exit tray on the brackets.
- c. Secure the brackets with fixing screws.

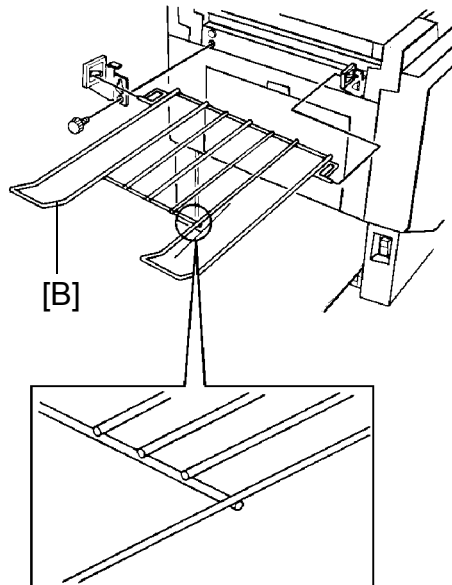

## 7. Loading Paper on the Paper Feed Table

- a. Open the paper feed table.
- b. Stack the paper neatly on the paper feed table.
- c. Position the paper feed side plates so that they lightly contact the paper on both sides.
- d. Position the paper delivery table for the printing paper size, using the scale on the table.
- e. Position the paper delivery side plate for the printing paper size, using the scale on the table.

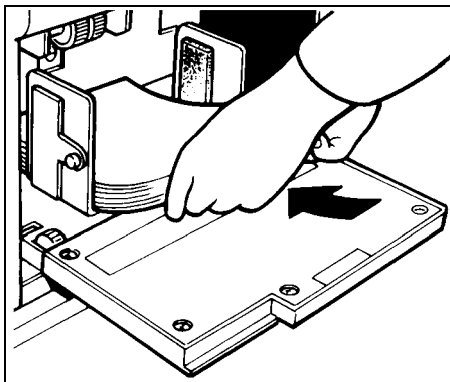

## 8. Installing the Master Roll (Type VT-M)

- a. While lifting up on the release lever, slide the scanner unit to the left.
- b. Attach a spool to each end of the master roll.
- c. Set the master roll in the machine.  
NOTE: The vinyl side faces down.
- d. Return the pressure release lever to the original position.
- e. Plug in the power cord and turn on the main switch.
- f. Press the Master Cut button.
- g. Remove the cut master paper.

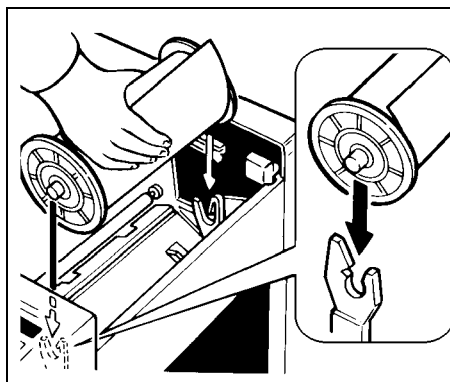

NOTE: Please confirm that the master paper is not bent or creased.

- h. Close the scanner unit.

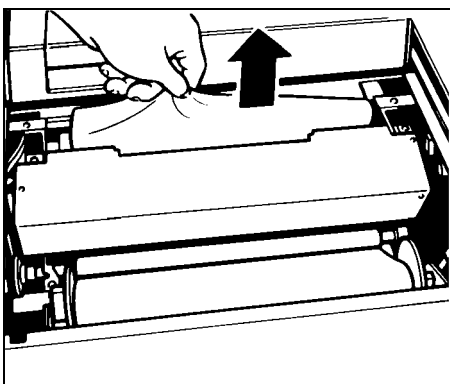
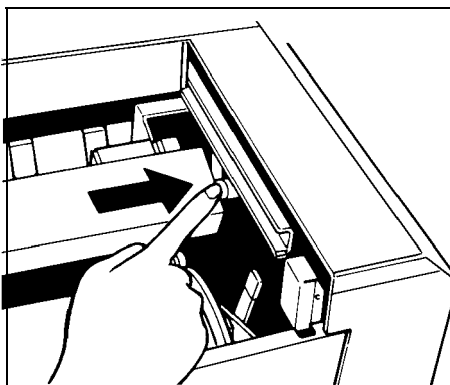

## 9. Installing the Ink Cartridge

- Open the front door and lower the ink holder.
- Remove the ink cartridge cap.
- Insert the ink cartridge into the ink holder and return the ink holder to the original position.
- Close the front door.

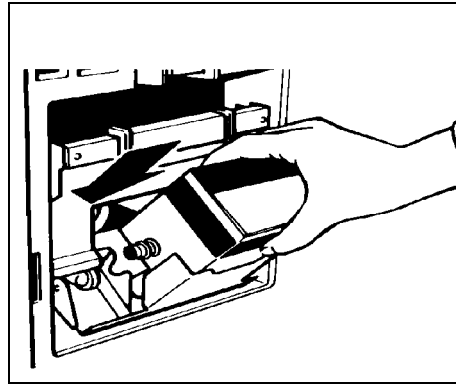

## 10. Idling

- While holding down the "0" key on the operation panel, press the Reset key.
- If  blinks on the operation panel, press the Reset key.

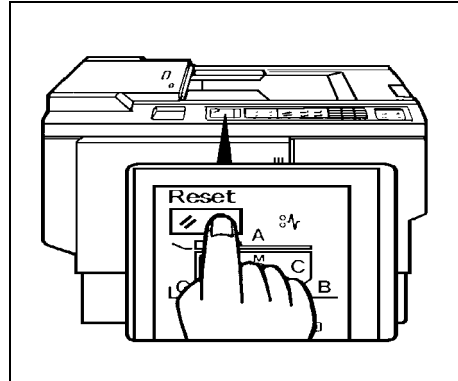

## 11. Test Printing

- Adjust the original guide to match the original size.
- Set the original face down.
- Input the desired number of prints with the number keys and press the Master Making key.
- After one sheet of paper is delivered, press the Print Start key to make prints at the lowest print speed (1) until the print image density stabilizes. Use a test chart to check for changes in the image density.
- Check the copy image after about one hundred prints.

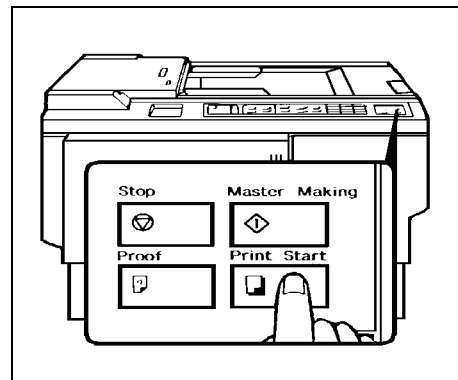
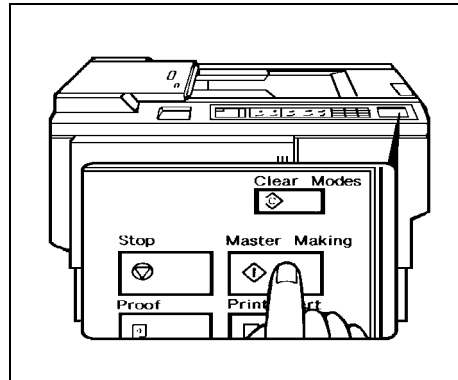

## 2.1 VT2100/2130/2150 INSTALLATION PROCEDURE

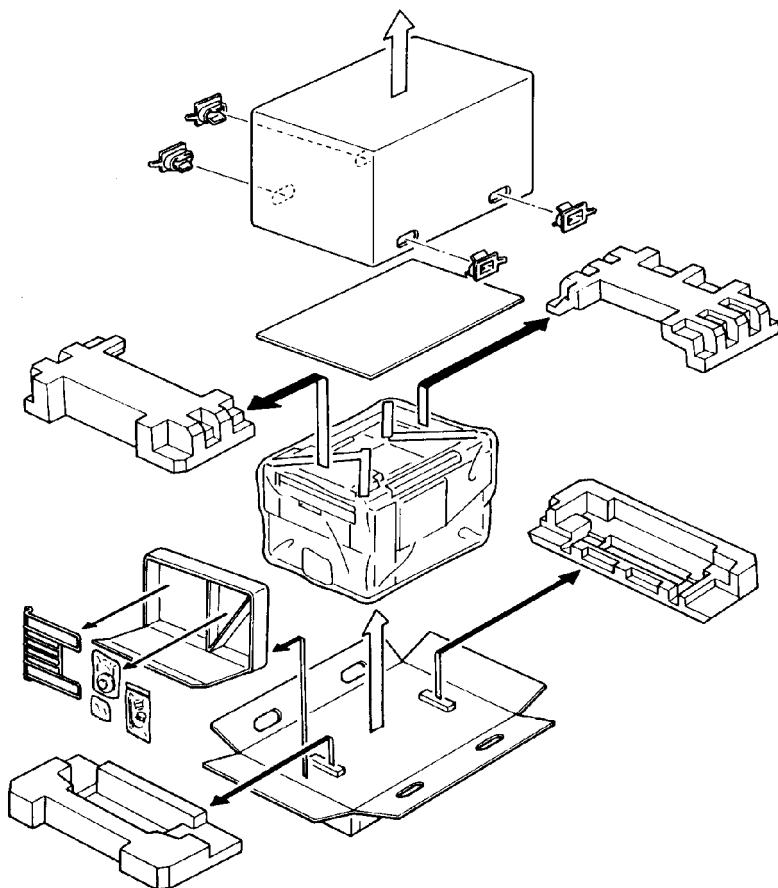

1. Make sure that you have all the accessories listed below.

(1) Original Exit Tray .....	1
(2) Right Tray Bracket.....	1
Left Tray Bracket.....	1
(3) Fixing Screws .....	2
(4) Master Spools .....	2
(5) Thermal Head Cleaner .....	1
(6) Operating Instructions (USA and Asia version only).....	1
(7) Operating Guide (USA and Asia version only).....	1
(8) NECR .....	1
(9) Installation Procedure (English) .....	1

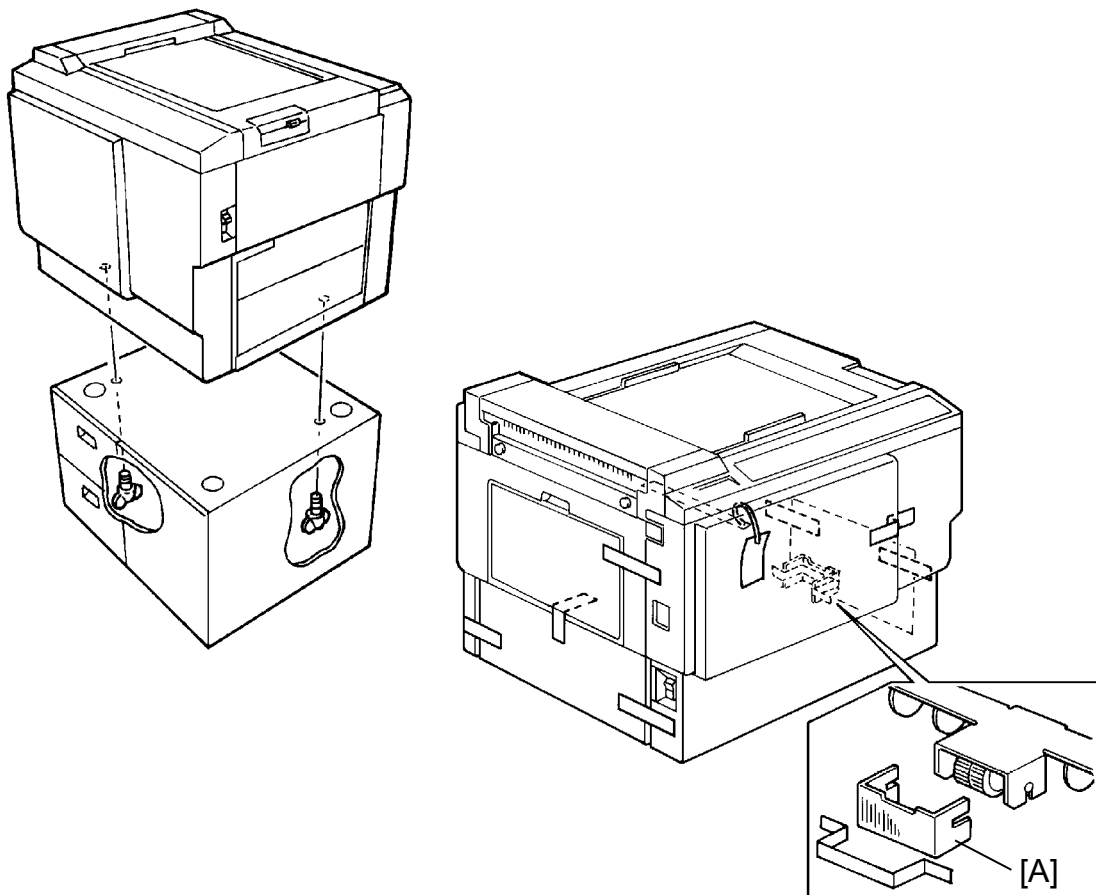

2. Mount the machine on the optional table (2 screws packed with table).
3. Remove the tape and string securing the covers and units as shown on the right.
  - a. Open the paper feed tray. Then remove the cushion plate [A] from the paper feed roller section.
  - b. Open the master delivery unit. Then remove the tape securing the paper delivery guide plate.

4. Remove the protective sheet [A] from the drum unit.

- a. Open the front door.
- b. Take out the drum unit.
- c. Remove the protective sheet from the master clamber.
- d. Reinstall the drum unit in the machine.

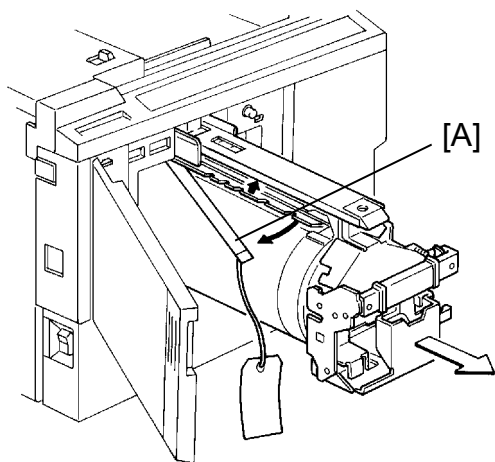

5. Install the original exit tray [B].

- a. Hook the right and left tray brackets on the stepped screws.
- b. Set the original exit tray on the brackets.
- c. Secure the brackets with fixing screws.

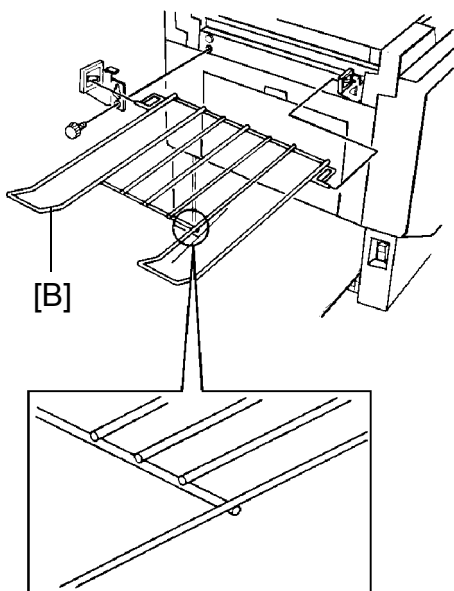

## 7. Loading Paper on the Paper Feed Table

- Open the paper feed table.
- Stack the paper neatly on the paper feed table.
- Position the paper feed side plates so that they lightly contact the paper on both sides.
- Position the paper delivery table for the printing paper size, using the scale on the table.
- Position the paper delivery side plate for the printing paper size, using the scale on the table.

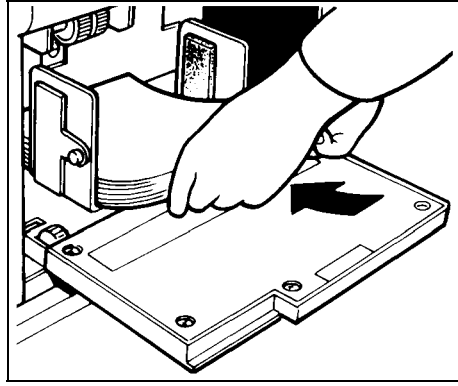

## 8. Installing the Master Roll (Type VT-M or S)

VT2100:                   Type VT-M  
VT2130/VT2150:       Type VT-S

- While lifting up on the release lever, slide the scanner unit to the left.
  - Attach a spool to each end of the master roll.
  - Set the master roll in the machine.
- NOTE: The vinyl side faces down.

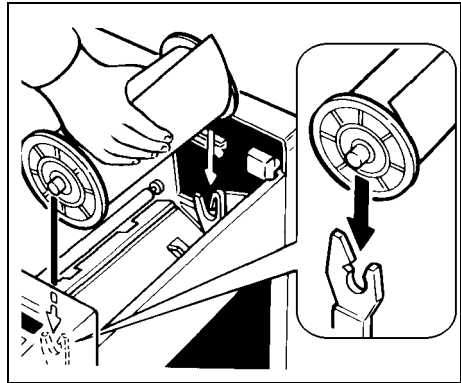

- Return the pressure release lever to the original position.
- Plug in the power cord and turn on the main switch.
- Press the Master Cut button.
- Remove the cut master paper.

NOTE: Please confirm that the master paper is not bent or creased.

- Close the scanner unit.

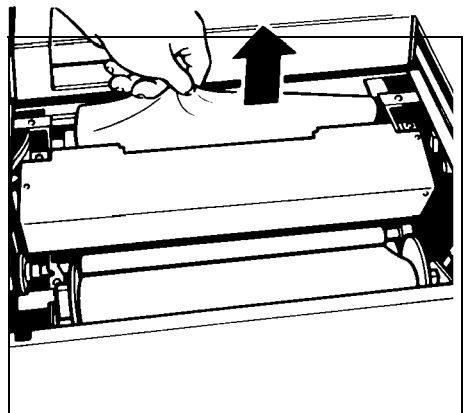
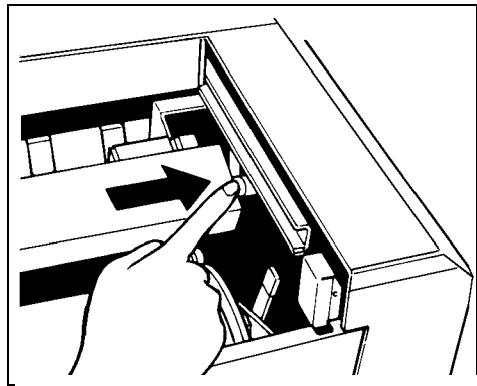



## 8. Installing the Ink Cartridge

- Open the front door and lower the ink holder.
- Remove the ink cartridge cap.
- Insert the ink cartridge into the ink holder and return the ink holder to the original position.
- Close the front door.

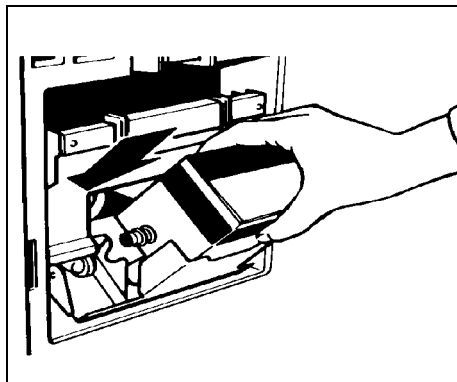

## 9. Idling

- While holding down the "0" key on the operation panel, press the Reset key.
- If  + D blinks on the operation panel, repeat the above procedure.

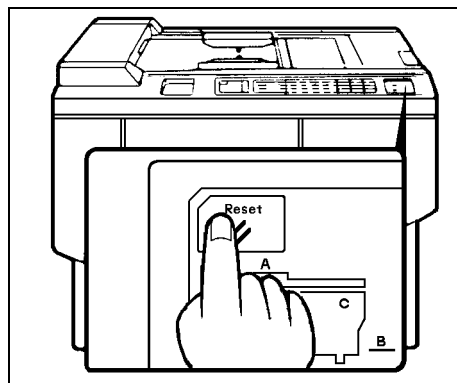

## 10. Test Printing

- Adjust the original guide to match the original size.
- Set the original face down.
- Input the desire number of prints with the number keys and press the Master Making key.

NOTE: With a new machine, the master paper misfeed indicator  + F blinks because there is no master yet on the drum. Press the Reset key, then press the Master Making key.

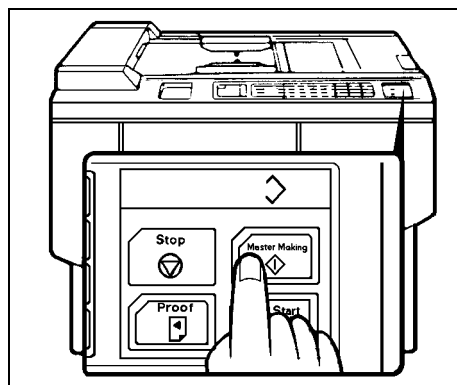

- After one sheet of paper is delivered, make prints at the lowest print speed (1) until the print image density stabilizes. Use a test chart to check for changes in the image density.
- Check the copy image after about one hundred prints.

## 4. INSTALLATION PROCEDURE COLOR DRUM VT2000 –M/S/LG (Option)

NOTE: There are three types of color drum units.

Color Drum Type VT2000-M:	For the VT2100/VT2300/VT2500
Color Drum Type VT2000-LG:	For the VT2130
Color Drum Type VT2000-S:	For the VT2150

1. Remove the protective sheet [A] from the drum unit.
2. Remove the tape securing the ink holder [B].
3. Stick a color indicator seal on the drum case and the ink holder. The seal must be the same color as the ink in use.

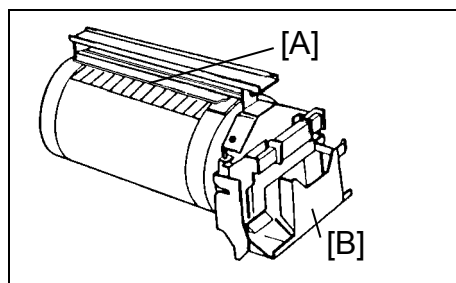

4. Remove the drum unit.
  - a. Leave the master wrapped around the removed drum to protect the drum from dust and drying.
  - b. Keep the removed drum unit in the drum case.

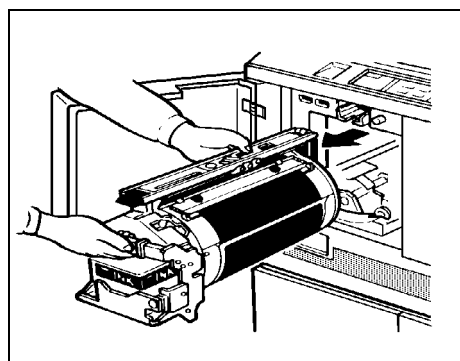

5. Install the color drum unit.



The color drum indicator  on the operation panel stays lit when the color drum is mounted in the machine.

6. Install the color ink.

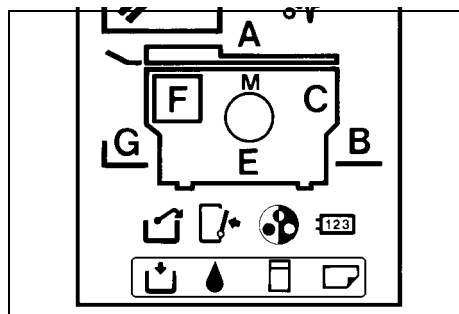
- a. Remove the ink cartridge cap.
- b. Insert the ink cartridge into the ink holder.



## 7. Idling

- a. While holding down the "0" key, press the Reset key on the operation panel.
- b. If  ( + D: VT2100/2130/2150) blinks, press the Reset key.

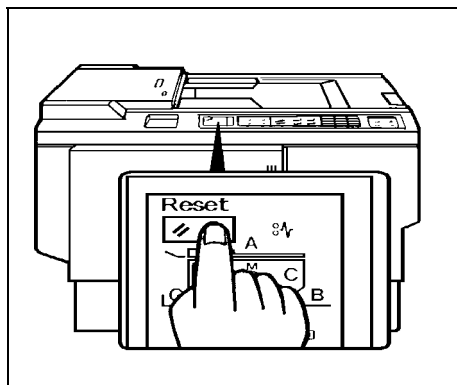

## 8. Test Printing

- a. Adjust the original guide to match the original size.
- b. Set the original face down.
- c. Input the desired number of prints with the number keys and press the Master Making key.

NOTE for VT2100/VT2130/2150:

With a new drum, the master paper misfeed indicator  + F blinks because there is no master yet on the drum. Press the Reset key, then press the Master Making key.

- d. After one sheet of paper is delivered, press the Print Start key to make prints at the lowest print speed (1) until the print image density stabilizes. Use a test chart to check the image density.
- e. Check the copy image after about one hundred prints.

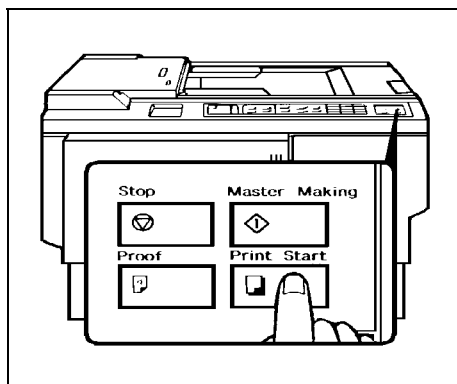
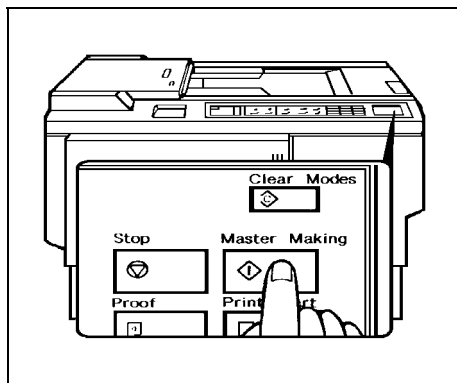

## 5. CASSETTE INSTALLATION PROCEDURE (Option)

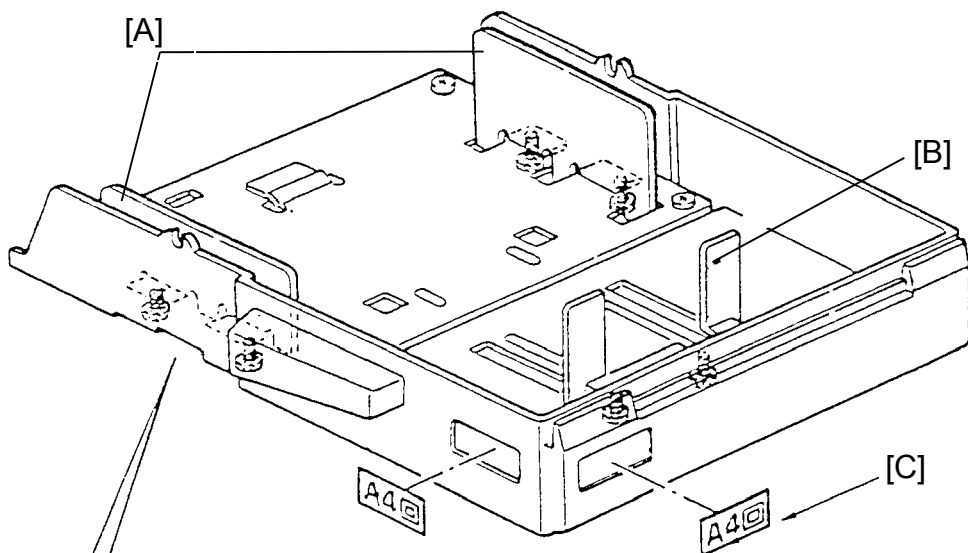

1. Turn the cassette over.
2. Use a coin to loosen the 6 screws securing the side fences [A] and the rear fence [B].
3. Move the 3 fences to the desired paper size position and tighten the 6 screws.  
NOTE: The paper size positions are marked on the cassette bottom.
4. Affix the paper size decals [C] to the cassette at the positions shown.

**SECTION 4**  
**SERVICE TABLES**

# 1. MAINTENANCE TABLES

---

## 1.1 LUBRICATION POINTS

Lubricate after removing adhering ink and paper dust.

Lubrication Point	Interval	Type
Bearings for drum drive shaft	yearly	Oil
Bearing for each cam shaft	yearly	Oil
Bearing for main motor shaft	yearly	Oil
Bearing for speed reduction shaft	yearly	Oil
Gears on the drum drive shaft	yearly	Grease
Gears for each cam	yearly	Grease
Paper feed sector gear	yearly	Grease
Second feed sector gear	yearly	Grease
Edge of each cam	yearly	Grease
Master pressure plate groove	yearly	Grease

Type of Oil and Grease

Oil: Motor Oil (SAE No.20)

Grease: Shell Albania No.2

## 1.2 USER'S MAINTENANCE

Please advise the customer to clean each item at suitable intervals.

Cleaning Point	Interval	Cleaner
Original platen cover	at any time	Cloth and water
Exposure glass	at any time	Cloth and glass cleaner
Thermal head	500 masters	Thermal Head cleaner
Paper feed rollers	at any time	Cloth, and soap and water (or ethyl alcohol)
Press roller	at any time	Cloth, and soap and water (or ethyl alcohol)

## 1.3 TABLE OF PERIODIC INSPECTION (every 6 months)

Item/Location	Step	Inspection Standard
Original platen cover	cleaning	Wipe off the stain with soft cloth dampened with ethyl alcohol.
Exposure glass	cleaning	Wipe with dry cloth.
Mirror/Sub mirror	cleaning	Use blower brush.
Thermal head	cleaning and image check	Wipe off the stain on the thermal head using thermal head cleaning kit. Check the print image. White line must not exist.
Platen roller	cleaning	Wipe off the paper powder with cloth dampened with water.
Sensors	inspection and cleaning	Check the performance of all the sensors. Remove the stains from sensors with dry cloth.
Press roller	cleaning	Wipe off the ink and paper powder with cloth dampened with ethyl alcohol.
Drum surface	cleaning	Wipe off the ink which is forced out from trail edge of a master and paper powder using cloth dampened with ethyl alcohol.
Master feed and delivery	inspection	Master should be properly fed and clamped, without generation of skew, fold, etc. Master should also be properly delivered without jam.
Paper feed and delivery	inspection	Actually print a few sheets to ensure that paper is smoothly fed and delivered, without generation of skew, folds, wrinkles, etc.
Second paper feed rollers	cleaning	Wipe off the ink and paper powder with cloth dampened with alcohol.
Original transport roller	cleaning	Wipe off paper powder with cloth dampened with water.
ADF (VT2300/VT2500)		
Pull-out roller	cleaning	Wipe off paper powder with cloth dampened with water.
Original feed roller	cleaning	Wipe off paper powder with cloth dampened with water.
Separation blade	cleaning	Wipe off paper powder with cloth dampened with water.

## 1.4 TABLE OF PERIODIC INSPECTION (every 12 months)

Item/Location	Step	Inspection Standard
Original platen cover	cleaning	Wipe off stains with soft cloth dampened with ethyl alcohol.
Exposure glass	cleaning	Wipe off the stain with soft cloth dampened with ethyl alcohol.
Fluorescent lamp	cleaning	Wipe with dry cloth.
Mirror/Sub mirror	cleaning	Use blower brush.
Thermal head	cleaning and inspection	Wipe off stains on thermal head using thermal head cleaning kit. Check the print image. White line must not exist.
Platen roller	cleaning	Wipe off paper powder with cloth dampened with water.
Paper feed roller	cleaning	Wipe off paper powder with cloth dampened with water and wipe off ink with cloth dampened with ethyl alcohol.
Separation roller	cleaning	Wipe off paper powder with cloth dampened with water and wipe off ink with cloth dampened with ethyl alcohol.
Sensors	inspection and cleaning	Check the performance of all the sensors. Wipe off stains on the sensor with dry cloth.
Master delivery rollers	cleaning	Wipe off the built up ink and paper powder on the master delivery rollers using cloth dampened with ethyl alcohol.
Master delivery belts	cleaning	Wipe off the built up ink and paper powder on the master delivery belts using cloth dampened with ethyl alcohol.
Second paper feed rollers	cleaning	Wipe off the built up ink and paper powder on the second feed rollers using cloth dampened with ethyl alcohol.
Press roller	cleaning	Wipe off the built up ink and paper powder on the press roller using cloth dampened with ethyl alcohol.
Drum surface	cleaning	Wipe off the ink, which is forced out from trail edge of a master, and paper powder using cloth dampened with ethyl alcohol.
Master feed and delivery	inspection	Master should be properly fed and clamped without generation of skew, fold, etc. Master should also be properly delivered without jam.



Item/Location	Step	Inspection Standard
Paper feed and delivery	inspection	Actually print a few sheets to ensure that paper is smoothly fed and delivered without generation of skew, folds, wrinkles, etc.
Original transport roller	cleaning	Wipe off paper powder with cloth dampened with water.
Lubrication points	Lubrication	Lubricate the lubrication points by following lubrication points list.
ADF (VT2300/VT2500)		
Pull-out roller	cleaning	Wipe off paper powder with cloth dampened with water.
Original feed roller	cleaning	Wipe off paper powder with cloth dampened with water.
Separation blade	cleaning	Wipe off paper powder with cloth dampened with water.

## 1.5 TABLE OF SERVICE CALL INDICATIONS

Indication	Trouble	Possible causes
E 01	Malfunction in cutter section: The cutter motor does not reach both right and left cutter position detecting switches within 2 seconds	1) Drive wire cut 2) Drive section malfunction 3) No power supply
E 02	Malfunction in the paper table drive section: The lower limit sensor or the paper table height sensor is not turned off even though the paper table UP or Down signal is applied	1) Drive worm gear broken 2) Mounting screw of the worm gear broken 3) No power supply
E 03	Malfunction in the program:	1) PROM defective 2) Control PCB defective
E 04	Temperature of the thermal head or the power supply unit is high: Temperature of the thermal head becomes greater than 57°C or the temperature of the power supply unit becomes greater than 85°C when the machine is in stand-by condition	1) Thermistor defective 2) Thermal head defective 3) Power supply unit defective

Indication	Trouble	Possible causes
E 05	Malfunction in the image shifting section:	1) Encoder connector of the image shifting section disconnected 2) Encoder defective
E 06	Mechanical lock: When a paper jam or part failure occurs, the decoder detects that the motor speed is incorrect if this occurs, the main motor turns off. This prevents any further damage its components or fuse failure.	1) Paper Jam 2) Parts failure
E07	Malfunction in the program (PROM). When using I/O check mode, "E07" lights up if the ROM is defective. NOTE: When "E03" is lit, check whether or not the PROM is defective using I/O check mode.	ROM defective.
E08	The pulse width applied to the thermal head is out of standard	Thermal head drive board defective.
	The power supply unit temperature reaches 85°C	Power supply unit defective (Thermal guard failure)

## 2. DIP SW, LED, VR TABLES

### 2.1 VT2300/VT2500 DIP SW (on the main control PCB)

NO. DIP SW	Function	Remarks
1. DPS101-1	Cover Open	Turn on to disable all cover safety switch functions except ADF cover safety. (Normal: OFF)
2. DPS101-2	ADF Cover Open	Turn on to release ADF cover.
3. DPS102-1	Key Counter (Option)	Turn on when installing Key Counter. (Normal: OFF)
4. DPS102-2	Buzzer ON/OFF	Turn on to sound the beeper. (Normal: OFF)
5. DPS102-3	Initial Print	Once: OFF, Twice: ON (Normal: OFF)
6. DPS102-4	ON Line-1	Turn on to use the machine with a PC. (Normal: OFF)
7. DPS102-5	Drum Master Detection	Turn on to detect the master on the drum. (Normal: ON)
8. DPS102-6	Paper Size Detection	Selects the paper size. (ON: LT version, OFF: A4 version)
9. DPS102-7	I/O Check Mode Access Procedure	Selects the I/O Check mode access procedure. (ON: Europe/Asia version, OFF: US version)
10. DPS102-8	ON Line-2	Turn on to use the machine with the Print Box. (Japanese version only)

### 2.2 VT2300/VT2500 PHOTO DIODE (on the main control PCB)

NO. LED	Function	Remarks
1. LED-101	Main Motor ON	When main motor turns on, LED lights.
2. LED-102	Master Eject SN Detection	When master is detected, LED lights.
3. LED-103	1st Paper Exit SN Detection	When paper is detected, LED lights.
4. LED-104	2nd Paper Exit SN Detection	When paper is detected, LED lights.
5. LED-105	Drum Master SN Detection	When master is detected, LED lights.
6. LED-106	Ink Detection	When ink is detected LED lights.

## 2.3 VT2300/VT2500 VR

NO. VR	PCB	Function
1. VR-101	Main	Main Motor Speed Adjustment
2. VR-102	Main	2nd Paper Exit Detection Adjustment
3. VR-103	Main	Drum Master Detection Adjustment
4. VR-104	Main	Master Eject Detection Adjustment
5. VR-105	Main	1st Paper Exit Detection Adjustment
6. VR-1	A/D Conversion	White Level Adjustment
7. VR-2	A/D Conversion	Black Level Adjustment
8. VR-201	Power Supply	Thermal Head Voltage Adjustment (16V)
9. VR-204	Power Supply	Vcc(+5V) Line Voltage Adjustment
10. VR-901	Ink Detecting	Ink Detecting Adjustment

## 2.4 VT2300/VT2500 DIP SW (on the image processing PCB)

NO. DIP SW	Function												
1. DPS400-1	Enlarge/Reduction Compensation Switch												
2. DPS400-2	Enlarge/Reduction Compensation Switch												
3. DPS400-3	Enlarge/Reduction Compensation Switch												
4. DPS400-4	Reproduction Ratio (ON: LT Version OFF: A4 Version)												
5. DPS400-5	Thermal Head (Pulse Control)												
	Image Density High ←————→ Low												
6. DPS400-6	<table style="border: none; margin-left: 20px;"> <tr> <td style="border: none;">400-5</td> <td style="border: none;">→</td> <td style="border: none;">ON</td> <td style="border: none;">ON</td> <td style="border: none;">OFF</td> <td style="border: none;">OFF</td> </tr> <tr> <td style="border: none;">400-6</td> <td style="border: none;">→</td> <td style="border: none;">ON</td> <td style="border: none;">OFF</td> <td style="border: none;">ON</td> <td style="border: none;">OFF</td> </tr> </table>	400-5	→	ON	ON	OFF	OFF	400-6	→	ON	OFF	ON	OFF
400-5	→	ON	ON	OFF	OFF								
400-6	→	ON	OFF	ON	OFF								
7. DPS400-7	Output the Test Pattern Image (Normal: ON)												
8. DPS400-8	Dither matrix selection (Normal: ON) (ON: 6 x 6 Dither matrix, OFF: 4 x 4 Dither matrix)												

## 2.5 VT2100/VT2130/VT2150 DIP SW (on the main control PCB)

No	DIP SW	FUNCTION	REMARKS
1	DPS100-1	Key Counter (Option)	Turn on when installing Key Counter. (Normal: OFF)
2	DPS100-2	Buzzer ON/OFF	Turn on to sound the beeper. (Normal: OFF)
3	DPS100-3	Initial Print	Once: OFF, Twice: ON (Normal: OFF)
4	DPS100-4	ON Line-2	Turn on DPS100-4 and 5 to use the machine with the Print Box. (Japanese version only)
5	DPS100-5		
6	DPS100-6	Main Motor Speed Adjustment	Turn on to adjust the main motor speed using VR100. (Normal: OFF)
7	DPS101-1	Cover Open	Turn on to disable all cover safety switch functions. (Normal: OFF)
8	DPS101-2	ADF Cover Open	Turn on to release ADF cover.(Normal: ON)

	DPS102-1	DPS102-2	VERSION	REMARKS
9	OFF	OFF	Japanese version	Class mode+B4 master processing
	OFF	ON	US version (VT2130)	Memory mode+LG master processing+I/O check mode access procedure for US version (See page 4-11)
	ON	OFF	Europe/Asia version (VT2100)	Memory mode+B4 master processing+I/O check mode access procedure for Europe/Asia version (See page 4-11)
	ON	ON	Europe/Asia version (VT2150)	Memory mode+A4 master processing+I/O check mode access procedure for Europe/Asia version (See page 4-11)

## 2.6 VT2100/VT2130/VT2150 PHOTODIODE (on the main control PCB)

No	LED	FUNCTION	REMARKS
1	LED100	Main Motor ON	When the main motor turns on, LED lights
2	LED101	2nd Paper Exit Detection	When paper is detected, LED lights
3	LED102	Ink Detection	When Ink is present, LED lights
4	LED103	1st Paper Exit Detection	When paper is detected, LED lights

## 2.7 VT2100/VT2130/VT2150 VR

No	VR	PCB	REMARKS
1	VR-100	Main	Main Motor Speed Adjustment
2	VR-102	Main	1st Paper Exit Detection Adjustment
3	VR-101	Main	2nd Paper Exit Detection Adjustment
4	VR-201	Power Supply	Thermal Head Voltage Adjustment (16V)
5	VR-203	Power Supply	Adjust the VCC (+5V) Line Voltage
6	VR-901	Ink Detecting	Ink Detecting Adjustment
7	VR-600	A/D Conversion	White Level adjustment

## 2.8 VT2100/VT2130/VT2150 DIP SW (on the image processing PCB)

NO. DIP SW	Function												
1. DPS400-1	Enlarge/Reduction Compensation Switch												
2. DPS400-2	Enlarge/Reduction Compensation Switch												
3. DPS400-3	Enlarge/Reduction Compensation Switch												
4. DPS400-4	Reproduction Ratio (ON: LT Version OFF: A4 Version)												
5. DPS400-5	Thermal Head (Pulse Control)												
	Image Density High ←————→ Low												
6. DPS400-6	<table style="border: none; margin-left: 20px;"> <tr> <td style="padding-right: 10px;">400-5</td> <td style="padding-right: 10px;">→</td> <td>ON</td> <td>ON</td> <td>OFF</td> <td>OFF</td> </tr> <tr> <td>400-6</td> <td>→</td> <td>ON</td> <td>OFF</td> <td>ON</td> <td>OFF</td> </tr> </table>	400-5	→	ON	ON	OFF	OFF	400-6	→	ON	OFF	ON	OFF
400-5	→	ON	ON	OFF	OFF								
400-6	→	ON	OFF	ON	OFF								
7. DPS400-7	Output the Test Pattern Image (Normal: ON)												
8. DPS400-8	Not used												



## 3. SERVICE PROGRAM MODE (I/O Check Mode)

### 3.1 HOW TO ACCESS I/O CHECK MODE

This program checks electrical components. The procedure for accessing the program is as follows:

1. Turn off the power switch.

2. A4 version:

Remove the front cover of the master eject unit to access the Full Master Detecting switch [A]. Turn on the power switch while holding down the Print Start key, Stop key, Clear key and Full Master Detecting Switch [A]. This accesses I/O check mode.

LT version:

Turn on the power switch while holding down the Print Start key, Stop key, and Clear key. This accesses I/O check mode.

**NOTE:** When the I/O check mode is accessed, only the 141% enlargement (VT2300/2500) or the 71% (64%) reduction (VT2100/2130/2150) ratio LED, the left lighter image density LED, and the Line Mode LED light. Also, 1 is displayed in the memory indicator and 0 is displayed in the copy counter.

VT2300/VT2500:

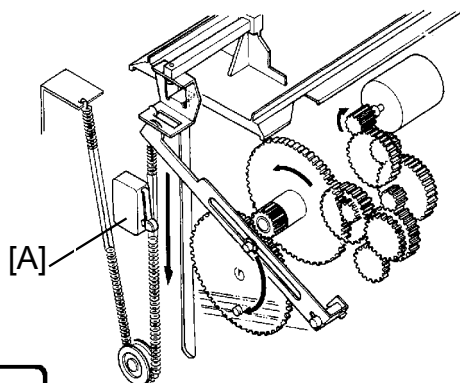
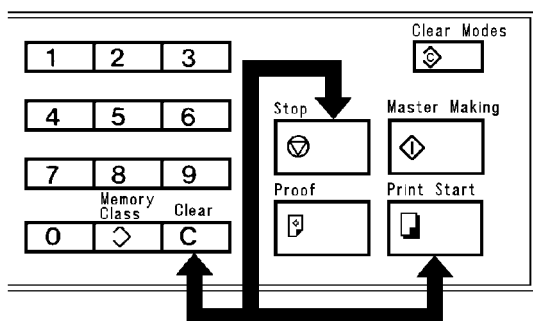

VT2100/VT2130/VT2150:

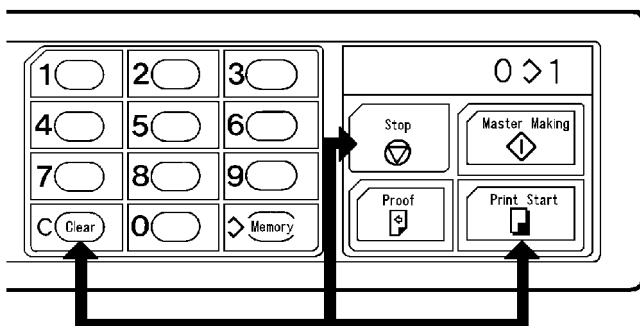

[A4 Version Only]



3. Press the Memory/Class key to select either "Input" or "Output".

Memory Indicator "1" — Input

Memory Indicator "0" — Output

4. Use the Numeral keys to enter the desired input or output number in the copy counter. (See the Service Program Table.)

5. a) In input mode, all Image Shift Position indicators [A] turn on when a switch or sensor that is being tested is actuated.

VT2300/VT2500:

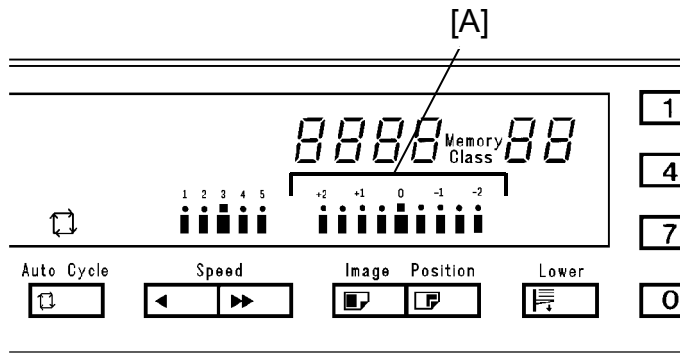

VT2100/VT2130/VT2150:

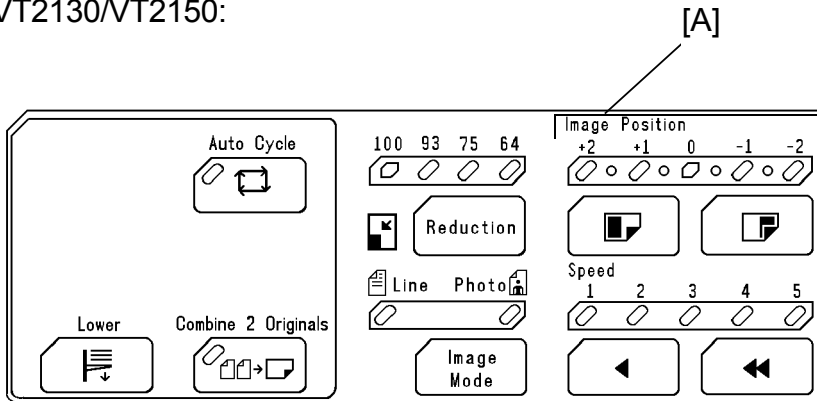

b) In output mode, the component corresponding to the number entered with the Number keys turns on when the Print Start key is pressed.

\* Press the Clear key to set the counter number in the copy counter.

6. After completion of the Service Program mode, turn off the power switch to clear the I/O check mode.

### 3.2 SERVICE PROGRAM TABLE: VT2300/VT2500

Output Mode:

COUNTER INDICATION	OUTPUT
0001-0	Turns on the drum (10 rpm).
0002-0	Turns on the drum (30 rpm).
0003-0	Turns on the drum (60 rpm).
0004-0	Turns on the paper table drive motor (up).
0005-0	Turns on the paper table drive motor (down).
0006-0	Turns on the vacuum motor.
0007-0	Turns on the master eject solenoid.
0008-0	Turns on the master eject clamper opening solenoid.
0009-0	Turns on the master feed clamper opening solenoid.
0010-0	Turns on the reversing roller solenoid.
0011-0	Turns on the paper feed solenoid and the printing pressure solenoid.
0012-0	Turns on the ink supply solenoid.
0013-0	Turns on the original transport motor.
0014-0	Turns on the master feed motor.
0015-0	Turns on the fluorescent lamp.
0016-0	Master Process Command (Photo LED ON)
0017-0	Reverses the master eject motor (Turn the eject rollers).
0018-0	Turns on the master eject motor (Pressure plate up/down).
0019-0	Turns on the cutter motor (Moves it from front to rear).
0020-0	Turns on the cutter motor (Moves it from rear to front).
0021-0	Turns the image shifting motor in (+) direction.
0022-0	Turns the image shifting motor in (-) direction.
0023-0	Turns on the magnetic counter for paper.
0024-0	Turns on the magnetic counter for master.
0025-0	Turns on the drum reverse rotation relay.
0026-0	Magnification ratio : 100% (LED ON)
0027-0	Magnification ratio : 93% (LED ON)
0028-0	Magnification ratio : 82% (A4 version)/ 75% (LT version) (LED ON)
0029-0	Magnification ratio : 71% (A4 version)/ 64% (LT version) (LED ON)
0030-0	Turn on the drum (10 rpm), the paper feed solenoid and the printing pressure solenoid.
0031-0	Tape dispenser (option) feeds out strips of paper.
0032-0	Turns on the ADF drive motor.
0033-0	Turns on the ADF original pressure solenoid.
0034-0	Turns on the drum lock solenoid.
0035-0	Outputs the thermal head voltage (VHD).

NOTE: 0001-0 to 0006-0 and 0030-0 are not activated when the safety cover is open.

## 3.3 SERVICE PROGRAM TABLE: VT2300/VT2500

Input Mode:

COUNTER INDICATION	INPUT	
0001-1	SN: Master Eject Detection	(Indicator lights when sensor ON)
0002-1	SW: Pressure Plate Position	(Indicator lights when switch ON)
0003-1	SN: 2nd Original Detection	(Indicator lights when sensor ON)
0004-1	SN: Original Registration Detection	(Indicator lights when sensor ON)
0005-1	SN: 1st Drum Position Detection	(Indicator lights when sensor ON)
0006-1	SN: 2nd Drum Position Detection	(Indicator lights when sensor ON)
0007-1	SN: Master Detection	(Indicator lights when master is set)
0008-1	SN: Master Buckle Detection	(Indicator lights when master appears)
0009-1	SW: Left Cutter	(Indicator lights when switch ON)
0010-1	SW: Right Cutter	(Indicator lights when switch ON)
0011-1	SW: Master Eject Box	(Indicator lights when switch ON)
0012-1	SW: Full Master Detection	(Indicator lights when switch ON)
0013-1	SN: Paper End	(Indicator lights when paper is set)
0014-1	SN: Paper Table Low Limit	(Indicator lights when sensor ON)
0015-1	SN: Paper Table Height	(Indicator lights when sensor ON)
0016-1	SN: Pressure	(Indicator lights when sensor ON)
0017-1	SN: 1st Paper Exit	(Indicator lights when paper exists)
0018-1	SN: 2nd Paper Exit	(Indicator lights when paper exists)
0019-1	SW: Cover Safety/Drum Detection	(Indicator lights when switch ON)
0020-1	SN: Color Drum	(Indicator lights when color drum is set)
0021-1	DIP SW-1 (DIP102-1)	(Indicator lights when switch ON)
0022-1	DIP SW-2 (DIP102-2)	(Indicator lights when switch ON)
0023-1	DIP SW-3 (DIP102-3)	(Indicator lights when switch ON)
0024-1	DIP SW-4 (DIP102-4)	(Indicator lights when switch ON)
0026-1	SN: Ink Detecting	(Indicator lights when ink appears)
0027-1	SN: Thermistor	(Indicator lights when temp. is standard)
0028-1	Key: Proof	(Indicator lights when key ON)
0029-1	Key: Image Shift +	(Indicator lights when key ON)
0030-1	Key: Image Shift -	(Indicator lights when key ON)
0031-1	SW: Drum Rotation	(Indicator lights when switch ON)
0032-1	SW: Master Manual cut	(Indicator lights when switch ON)
0033-1	SN: 1st Original Detection	(Indicator lights when sensor ON)
0034-1	SN: Paper Size 1	(Indicator lights when sensor ON)
0035-1	SN: Paper Size 2	(Indicator lights when sensor ON)
0036-1	SN: Paper Size 3	(Indicator lights when sensor ON)
0037-1	SN: Drum Master Detection	(Indicator lights when sensor ON)

### 3.4 SERVICE PROGRAM TABLE: VT2100/VT2130/VT2150

Output Mode:

COUNTER INDICATION	OUTPUT
0001-0	Turns on the drum (10 rpm).
0002-0	Turns on the drum (30 rpm).
0003-0	Turns on the drum (60 rpm).
0004-0	Turns on the paper table drive motor (up).
0005-0	Turns on the paper table drive motor (down).
0006-0	Turns on the vacuum motor.
0007-0	Turns on the master eject solenoid.
0008-0	Turns on the master eject clamper opening solenoid.
0009-0	Turns on the master feed clamper opening solenoid.
0010-0	Turns on the reversing roller solenoid.
0011-0	Turns on the paper feed solenoid and the printing pressure solenoid.
0012-0	Turns on the ink supply solenoid.
0013-0	Turns on the original transport motor.
0014-0	Turns on the master feed motor.
0015-0	Turns on the fluorescent lamp.
0016-0	Master Process Command (Photo LED ON)
0017-0	Reverses the master eject motor (Turn the eject rollers).
0018-0	Turns on the master eject motor (Pressure plate up/down).
0019-0	Turns on the cutter motor (Moves it from front to rear).
0020-0	Turns on the cutter motor (Moves it from rear to front).
0021-0	Turns the image shifting motor in (+) direction.
0022-0	Turns the image shifting motor in (-) direction.
0023-0	Turns on the magnetic counter for paper.
0024-0	Turns on the magnetic counter for master.
0025-0	Turns on the drum reverse rotation relay.
0026-0	Magnification ratio : 100% (LED ON)
0027-0	Magnification ratio : 93% (LED ON)
0028-0	Magnification ratio : 82% (A4 version)/ 75% (LT version) (LED ON)
0029-0	Magnification ratio : 71% (A4 version)/ 64% (LT version) (LED ON)
0030-0	Turn on the drum (10 rpm), the paper feed solenoid and the printing pressure solenoid.
0031-0	Tape dispenser (option) feeds out strips of paper.
0032-0	Turns on the ADF drive motor (Not used).
0033-0	Turns on the ADF original pressure solenoid (Not used).
0034-0	Outputs the thermal head voltage (VHD).

NOTE: 0001-0 to 0006-0 and 0030-0 are not activated when the safety cover is open.

## 3.5 SERVICE PROGRAM TABLE: VT2100/VT2130/VT2150

Input Mode:

COUNTER INDICATION	INPUT	
0001-1	SW: Master Eject Detection	(Indicator lights when sensor ON)
0002-1	SW: Pressure Plate Position	(Indicator lights when switch ON)
0003-1	SN: 2nd Original Detection	(Indicator lights when sensor ON)
0004-1	SN: Original Registration Detection	(Indicator lights when sensor ON)
0005-1	SN: 1st Drum Position Detection	(Indicator lights when sensor ON)
0006-1	SN: 2nd Drum Position Detection	(Indicator lights when sensor ON)
0007-1	SN: Master Detection	(Indicator lights when master is set)
0008-1	SN: Master Buckle Detection	(Indicator lights when master appears)
0009-1	SW: Left Cutter	(Indicator lights when switch ON)
0010-1	SW: Right Cutter	(Indicator lights when switch ON)
0011-1	SW: Master Eject Box	(Indicator lights when switch ON)
0012-1	SW: Full Master Detection	(Indicator lights when switch ON)
0013-1	SN: Paper End	(Indicator lights when paper is set)
0014-1	SN: Paper Table Low Limit	(Indicator lights when sensor ON)
0015-1	SN: Paper Table Height	(Indicator lights when sensor ON)
0016-1	SN: Pressure	(Indicator lights when sensor ON)
0017-1	SN: 1st Paper Exit (LED103)	(Indicator lights when paper exists)
0018-1	SN: 2nd Paper Exit (LED101)	(Indicator lights when paper exists)
0019-1	SW: Cover Safety/Drum Detection	(Indicator lights when switch ON)
0020-1	SN: Color Drum	(Indicator lights when color drum is set)
0021-1	DIP SW-1 (DIP100-1)	(Indicator lights when switch ON)
0022-1	DIP SW-2 (DIP100-2)	(Indicator lights when switch ON)
0023-1	DIP SW-3 (DIP100-3)	(Indicator lights when switch ON)
0024-1	DIP SW-4 (DIP100-4)	(Indicator lights when switch ON)
0025-1	DIP SW-5 (DIP100-5)	(Indicator lights when switch ON)
0026-1	SN: Ink Detecting	(Indicator lights when ink appears)
0027-1	SN: Thermistor	(Indicator lights when temp. is standard)
0028-1	Key: Proof	(Indicator lights when key ON)
0029-1	Key: Image Shift +	(Indicator lights when key ON)
0030-1	Key: Image Shift -	(Indicator lights when key ON)
0031-1	SW: Drum Rotation	(Indicator lights when switch ON)
0032-1	SW: Master Manual Cut	(Indicator lights when switch ON)
0033-1	SN: 1st Original Detection	(Indicator lights when sensor ON)

## 4. TEST PATTERN IMAGE MODE

The purpose of this mode is to distinguish whether the cause of the image problem is located before or after the image processing.

**Output image:** The normal output of this test pattern image mode is one of the Dither matrix pattern as illustrated below.

**Master processing length:**

**Main scan (Horizontal) direction:** Full width of the thermal head

**Sub scan (Vertical) direction:** Same as the vertical size of the original set on the original table.

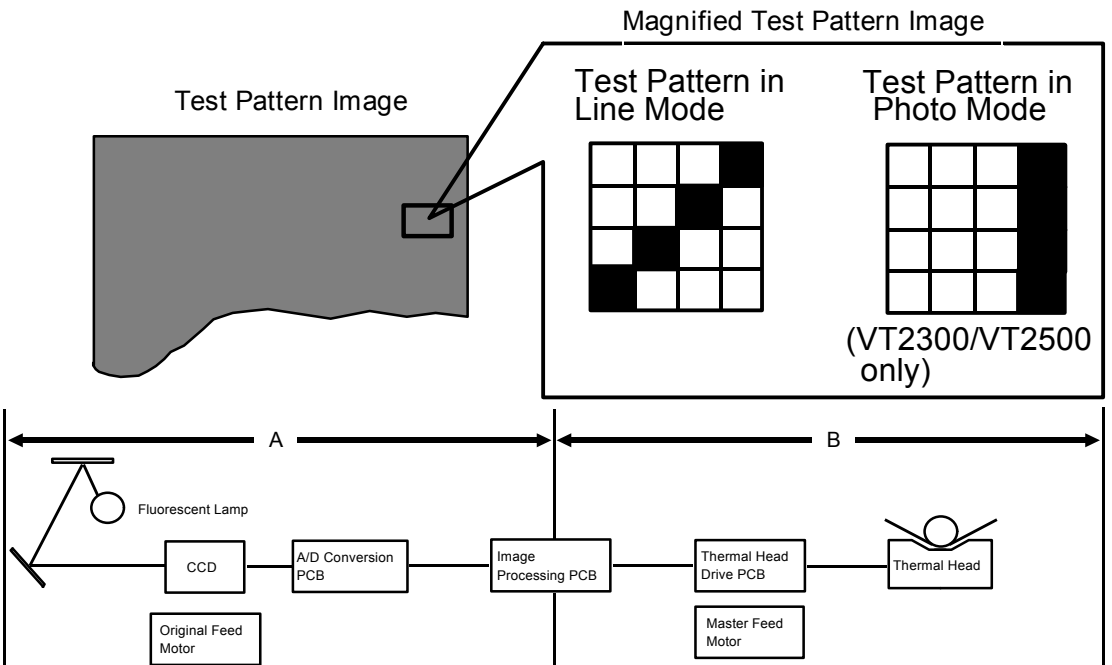

This test pattern is generated by the image processing PCB.

- [Example] **Problem:** Vertical white lines appear on the print.
- Possible Cause 1** If the same problem appears on the output image from the thermal head in Test Pattern image mode, the cause should exist in area B as shown above.
- Possible Cause 2** If the output image from the thermal head is correct in Test Pattern Mode but the output image in the normal mode is incorrect, the cause should exist in area A as shown above.

#### 4.1 OPERATION: (To Enter Test Pattern Image Mode)

- 1) Remove the front cover.
- 2) Turn off the DIP SW 400-7 on the image processing PCB only when the power switch is off.
- 3) Turn on the main switch.

VT2300/VT2500 only:

- 4) Press the Image Mode key to select the Test Pattern Image.

Test Pattern in Line Mode

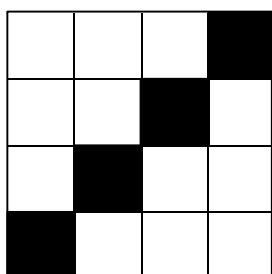

Test Pattern in Photo Mode

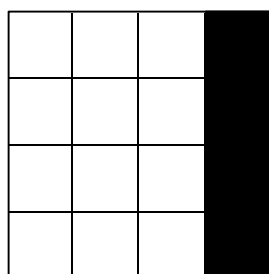

VT2100/VT2130/VT2150 only:

- 4) The following Test Pattern is made in both Line and Photo mode (i.e. it does not need to be selected).

Test Pattern in Line Mode/Photo Mode

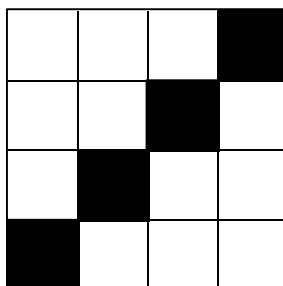

- 5) Set the original on the original table.

**CAUTION:** To prevent overheating of the thermal head, make the original as short as possible. Any type of original is suitable as the test pattern being used is in the image processing PCB memory.

- 6) Press the Master Making key and make prints.
- 7) After completion of the Test Pattern Image mode, turn on DIP SW 400-7.

## 5. DESIGNATED AREA CHECK MODE: VT2500

The command sheet image (designated area) and the original image can be printed at the same time to check the designated area and the positioning of the image within the designated area as follows:

- 1) Turn off the power switch.
- 2) Turn on the power switch while pressing the Make-up Key and the Reset Key.

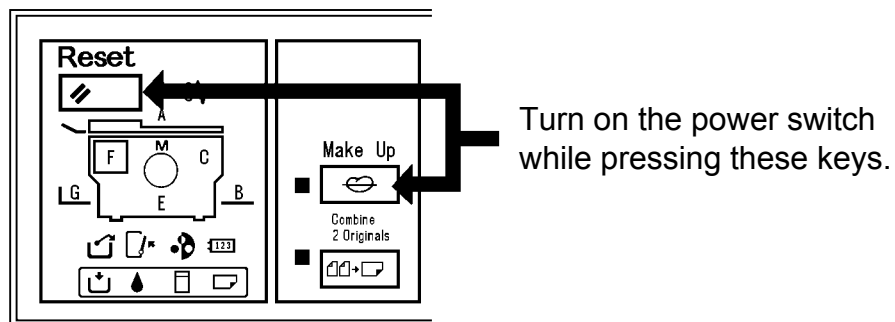

- 3) Press the Make-up Key ([Fn] is displayed in the counter.)
- 4) Press the "8" key ("8" is displayed in the counter.)

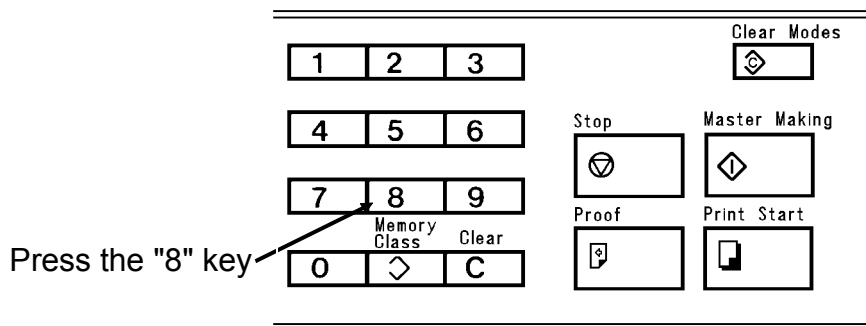

- 5) Set the command sheet and the original on the original table and press the Print Start key to make copies.

\* If white paper is used as an original, only the command sheet (the line showing the designate area) is printed.



Original

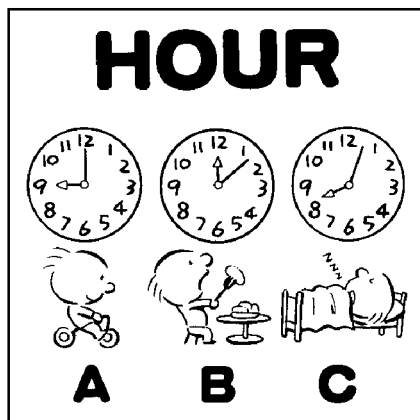

Command Sheet

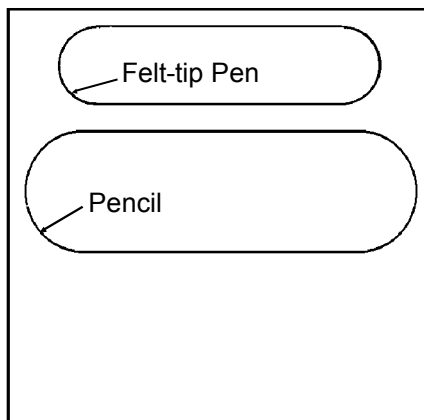

Printed image using "Fn 8"

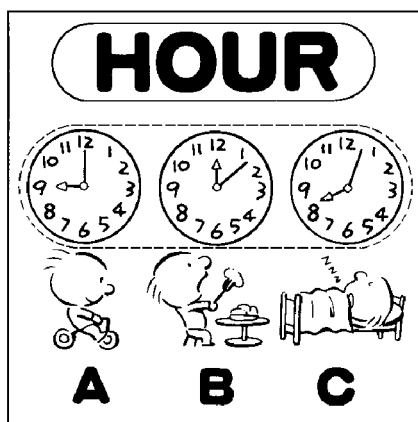

1) The designated areas marked using a pencil are depicted by dashed lines. This is because the line marked using a pencil is low density and thin, therefore the designated area is not recognized as a closed loop even if the line on the command sheet is a closed loop.

Therefore, the designated area can not be memorized.

2) The designated area marked using a black felt-tip pen is printed within the closed loop.

As the line of the designated area on the printed paper is a closed loop, the designated area is memorized.

## 6. OPTION/SUPPLY INTERCHANGEABILITY

0: Standard combination

Δ: Usable under certain conditions (\*See NOTES on page 4-23)

X: Cannot be used

		SS810	SS830	SS930	SS950	SS915	SS935	SS955
Masters	Type 800	0	0	Δ *1	Δ *1	Δ *2	Δ *2	Δ *2
	Type 900	X	X	0	0	Δ *3	Δ *3	Δ *3
	Type 905	X	X	Δ *4	Δ *4	0	0	0
	VT-S	X	X	X	X	X	X	X
	VT-M	X	X	X	X	X	X	X
	VT-L	X	X	X	X	X	X	X
Inks	Black	0	0	0	0	0	0	0
	Color (rd/bl/gn/br)	0	0	0	0	0	0	0
	VT-Black-800	X	X	X	X	X	X	X
Color Drums	Color Drum	0	0	0	0	Δ *6	Δ *7	Δ *7
	Color Drum Type 905	Δ *9	Δ *9	Δ *9	Δ *9	0	0	0
	Color Drum VT2000-M	Δ *11	Δ *11	Δ *11	Δ *11	0	0	0
	Color Drum VT2000-LG	X	X	X	X	X	X	X
	Color Drum VT2000-S	X	X	X	X	X	X	X
	Color Drum VT3000-L	X	X	X	X	X	X	X
	Color Drum VT3000-S	X	X	X	X	X	X	X
Others	Cassette B4	X	X	X	X	X	0	0
	Cassette VT3000-L	X	X	X	X	X	X	X
	Cassette VT3000-S	X	X	X	X	X	X	X
	Tape Marker Type 20	0	0	0	0	0	Δ *12	Δ *12
	Priport Table	0	0	0	0	0	0	0
	Priport Table VT3000	X	X	X	X	X	X	X

0: Standard combination

Δ: Usable under certain conditions (See NOTES on page 4-23)

X: Cannot be used

		VT2100	VT2130	VT2150	VT2300	VT2500	VT3500
Masters	Type 800	X	X	X	X	X	X
	Type 900	X	X	X	X	X	X
	Type 905	X	X	X	X	X	X
	VT-S	X	0	0	X	X	X
	VT-M	0	X	X	0	0	X
	VT-L	X	X	X	X	X	0
Inks	Black	0	0	0	0	0	Δ *5
	Color (rd/bl/gn/br)	0	0	0	0	0	0
	VT-Black-800	X	X	X	X	X	0
Color Drums	Color Drum	Δ *8	X	X	Δ *8	Δ *8	X
	Color Drum Type 905	Δ *10	X	X	Δ *10	Δ *10	X
	Color Drum VT2000-M	0	X	X	0	0	X
	Color Drum VT2000-LG	X	0	X	X	X	X
	Color Drum VT2000-S	X	X	0	X	X	X
	Color Drum VT3000-L	X	X	X	X	X	0
	Color Drum VT3000-S	X	X	X	X	X	0
Others	Cassette B4	X	X	X	0	0	X
	Cassette VT3000-L	X	X	X	X	X	0
	Cassette VT3000-S	X	X	X	X	X	0
	Tape Marker Type 20	0	0	0	0	0	0
	Priport Table	0	0	0	0	0	X
	Priport Table VT3000	X	X	X	X	X	0

## NOTES

1. The image density is lower than with a type 900 master; however, the ink set-off on the back side of the following pages is reduced.
2. The image density is lower than with a type 905 master; however, the ink set-off is reduced.
3. The image density is higher than with a type 905 master and the ink set-off is increased.
4. The image density is lower than with a type 900 master; however, the ink set-off is reduced and the image density in solid areas is more even.
5. When the 500 cc ink cartridge is installed, the ink holder spacer [A] (P/N C5264633) must be installed as shown.
6. The image density is slightly higher.
7. The drum cannot be used unless the black seal [B] (P/N C2074550) is affixed to the screen edge as shown. The drum lock function cannot be used.
8. The drum cannot be used unless the black seal [B] (P/N C2074550) is affixed to the screen edge as shown. The modified master clamber (P/N C2074948) must be installed. The drum lock function cannot be used.
9. The drum lock and the drum master detection functions cannot be used; however, the first few prints made when the Master Making key is pressed will be better than those made on a standard drum.
10. The modified master clamber (P/N C2074948) must be installed.
11. The drum lock and the drum master detection functions cannot be used; however, this drum produces better quality images than a standard drum.
12. The rear paper delivery side plate [C] (P/N C2136119) used on the VT series must be installed.

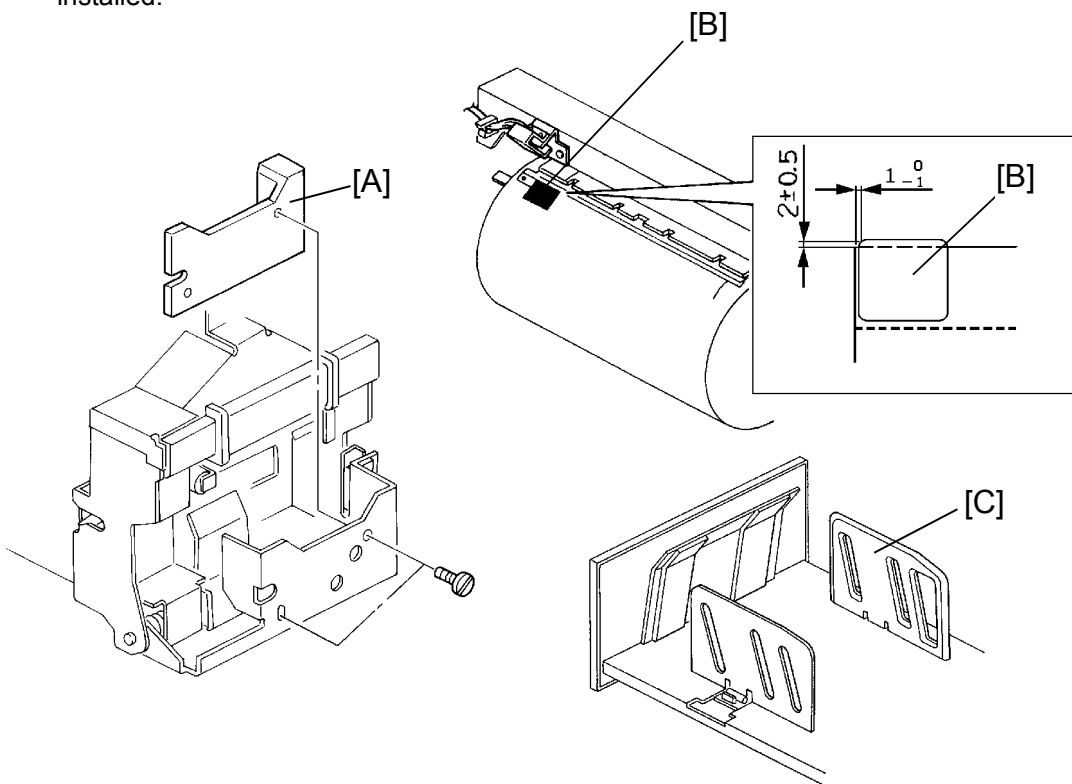

**SECTION 5**  
**REPLACEMENT**  
**AND**  
**ADJUSTMENT**

# 1. EXTERIOR

## 1.1 EXTERIOR COVER REPLACEMENT

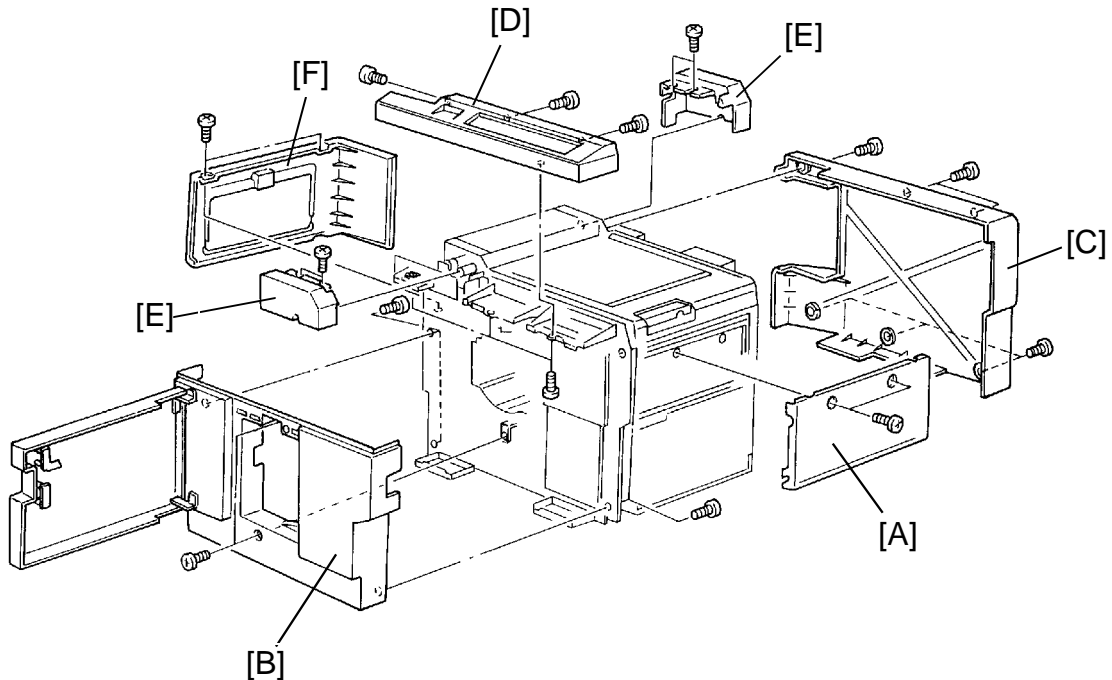

When adjusting or disassembling each sections, refer to the following procedure of how to remove the exterior covers.

[A] Master feed unit cover (2 screws). Slide the scanner unit to the left.

[B] Front cover (6 screws).

- Remove master feed unit cover [A] to remove upper right screw. Open the front door to remove the front screws.

[C] Rear cover (6 screws).

[D] Operation panel cover (6 screws).

- Remove front cover [B] to remove operation panel cover.

[E] Front and rear fluorescent lamp covers (2 screws each).

[F] Master eject cover (2 screws).

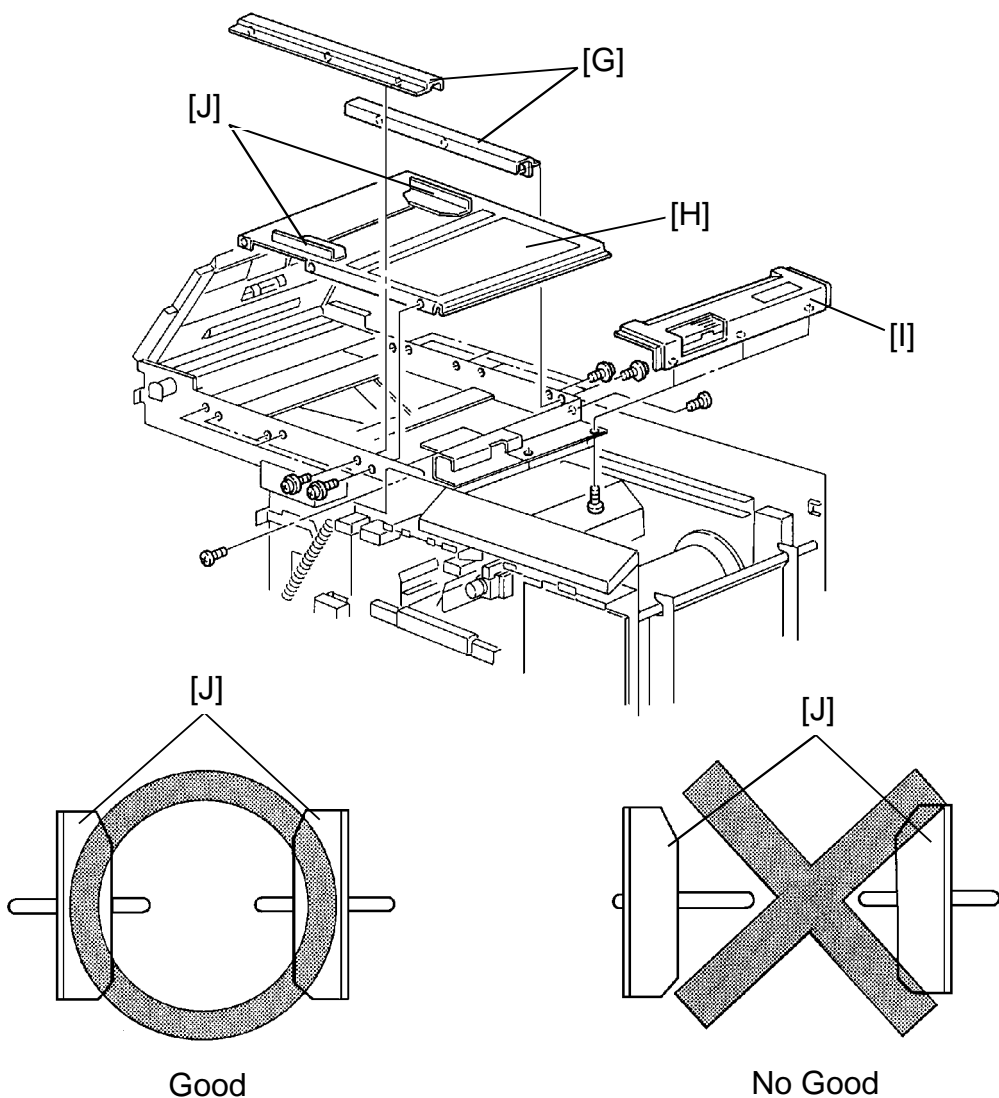

[G] Front and rear original table frames (3 screws each).

- Remove the operation panel cover [D] and rear cover [C] to remove the front and rear original table frames (See page 5-1).

[H] Original table (6 screws).

- Remove front and rear original table frames [G] to remove the original table.

**NOTE:** When installing the original table, make sure both original guides [J] are set in the same position in the grooves (See illustration).

[I] Original table cover (3 screws).

- Slide the scanner unit to the left.

## 2. ORIGINAL FEED SECTION

### 2.1 ORIGINAL FEED BELT TENSION ADJUSTMENT

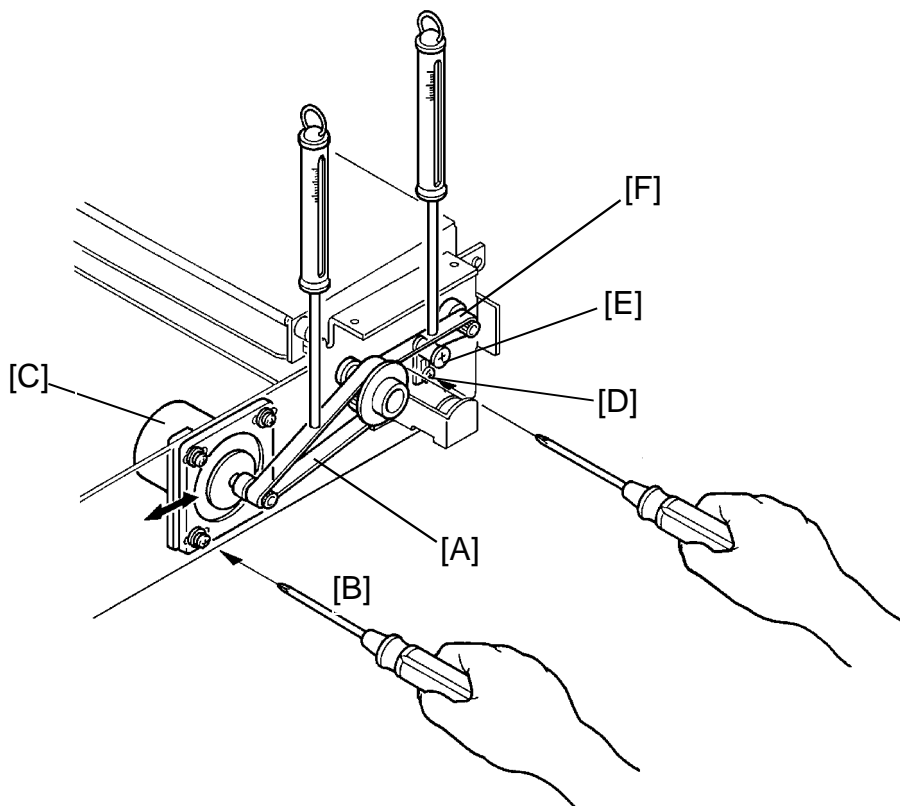

Purpose: To ensure proper original feed.

1. Remove the rear cover of the fluorescent lamp (2 screws).
2. Using a tension gauge, apply a 110-gram load at the center of the belt [A]. Make sure that the belt deflects 2 to 3 mm.
3. If not, loosen the mounting screws [B] of the original feed motor [C] and adjust belt tension by moving the original feed motor.
4. Using a tension gauge, apply a 110-gram load at the center of the belt [F]. Make sure that the belt deflects  $1.1 \pm 0.2$  mm.
5. If incorrect, loosen the mounting screw [D] and adjust belt tension by moving the belt tensioner [E].
6. After adjustment, retighten the mounting screws.



## 2.2 ORIGINAL PRESSURE SOLENOID ADJUSTMENT: VT2300/VT2500

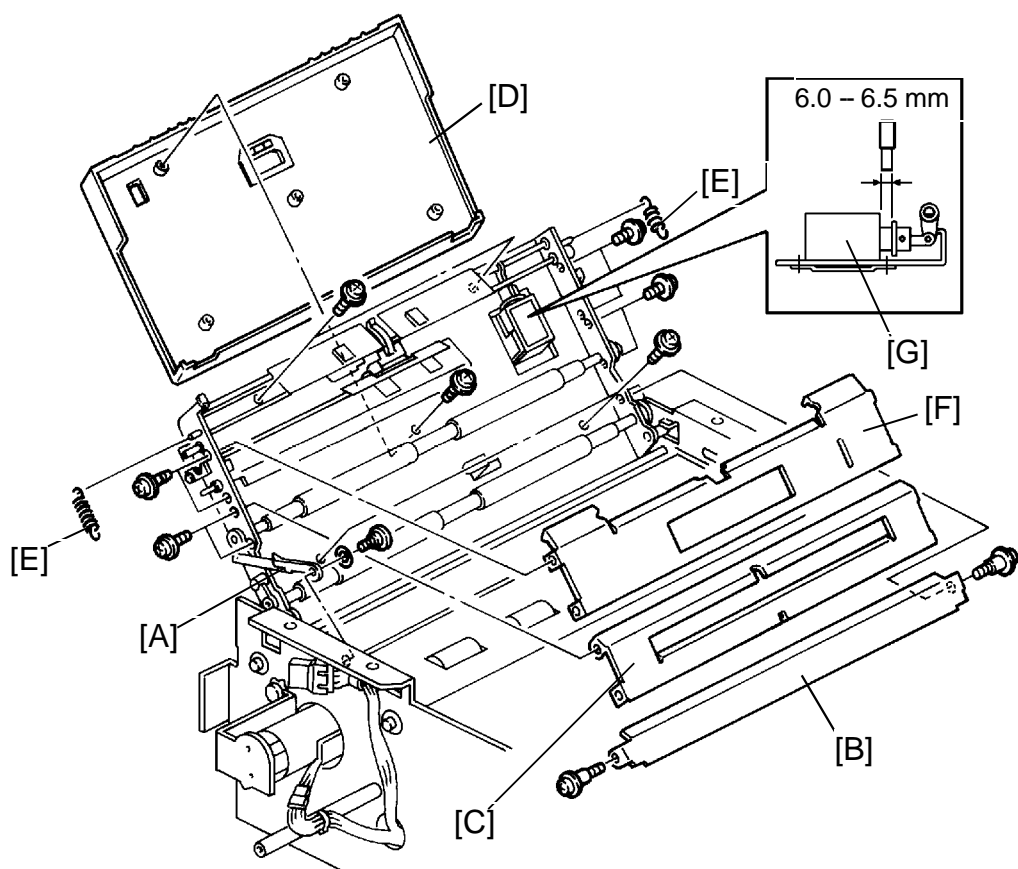

Purpose: To ensure that the originals are separated properly.

1. Remove the screw securing the stopper [A].
2. Remove the platen plate [B] (2 screws).
3. Remove the original guide [C] (4 screws).
4. Remove the ADF unit cover [D] (5 screws).
5. Unhook the both hook springs [E].
6. Remove the separation guide plate [F] (4 screws).
7. Adjust the original pressure solenoid [G] position so that the space between the E-ring and the rubber cushion is 6.0 to 6.5 mm when the solenoid is turned off.

## 2.3 TRANSPORT ROLLER PRESSURE ADJUSTMENT: VT2300/VT2500

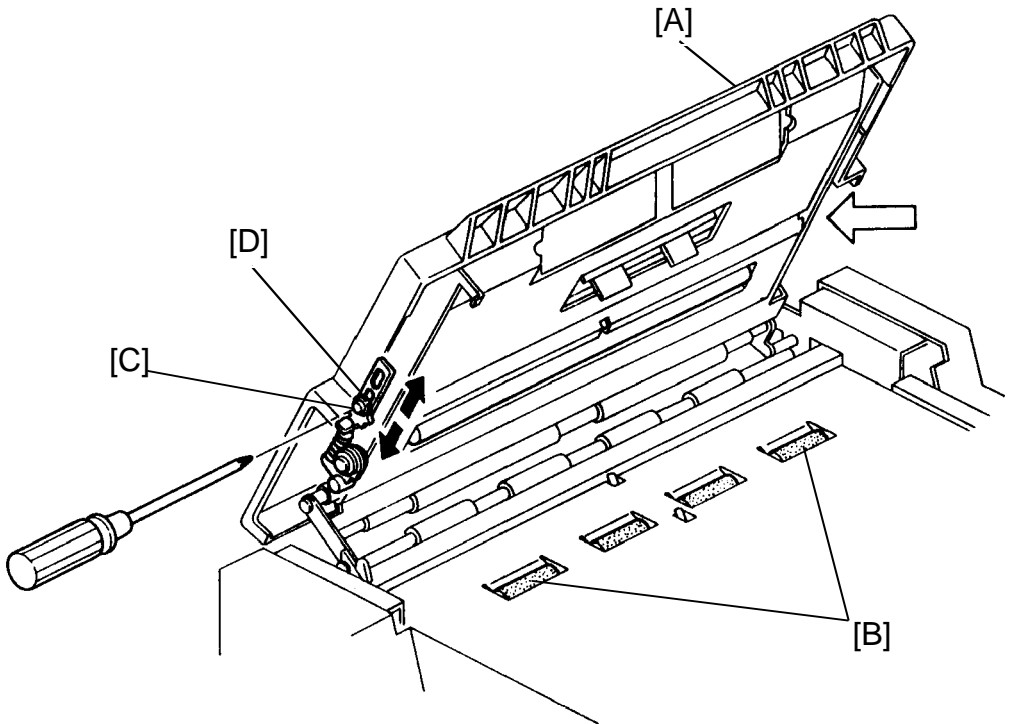

Purpose : To ensure that the original does not skew

1. Set the ADF ON/OFF switch to OFF.
2. Open the scanner unit [A] and place strips of paper (45 g/m<sup>2</sup>) over the front and rear ends of the transport roller [B].
3. Close the scanner unit.
4. Confirm that the strips of paper can be pulled out at both ends of the roller with the same amount of force.
5. If the pressure is not the same at both ends, loosen the mounting screw [C] and adjust the transport roller pressure by sliding the adjustment plate [D] up or down.
6. Tighten the mounting screw after adjusting the roller pressure.

## 2.4 EXPOSURE GLASS REPLACEMENT

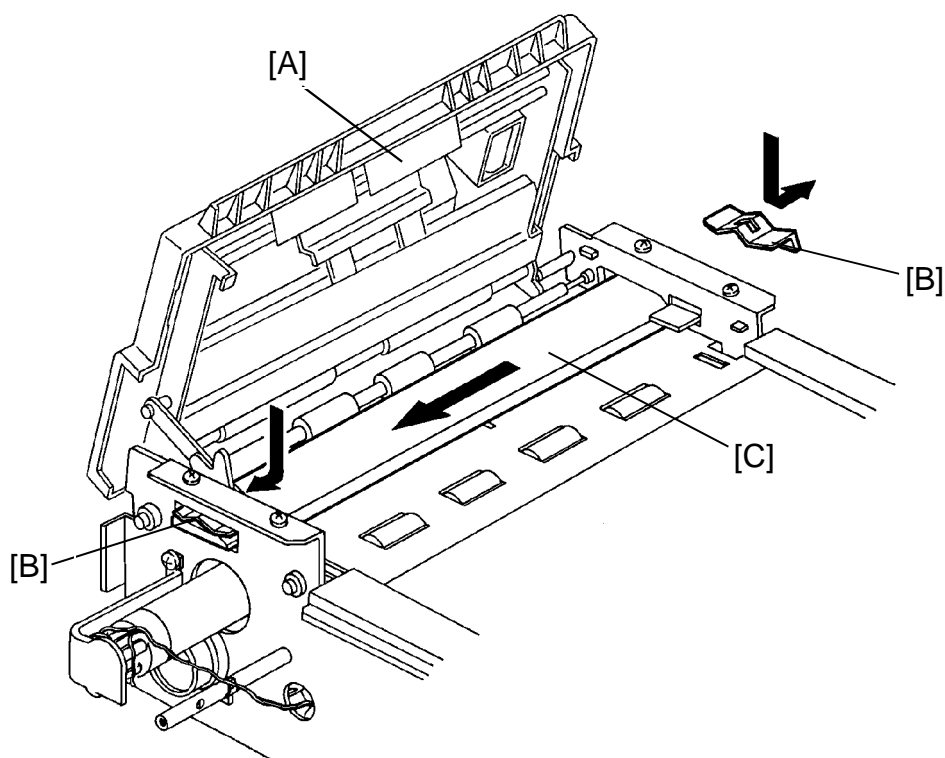

1. Slide the scanner unit to the left.
2. Open the ADF unit [A].
3. Remove the front and rear fluorescent lamp covers (2 screws each).
4. Remove both the exposure glass leaf springs [B].
5. Carefully remove the exposure glass [C].

## 2.5 EXPOSURE LAMP / HEATER REPLACEMENT

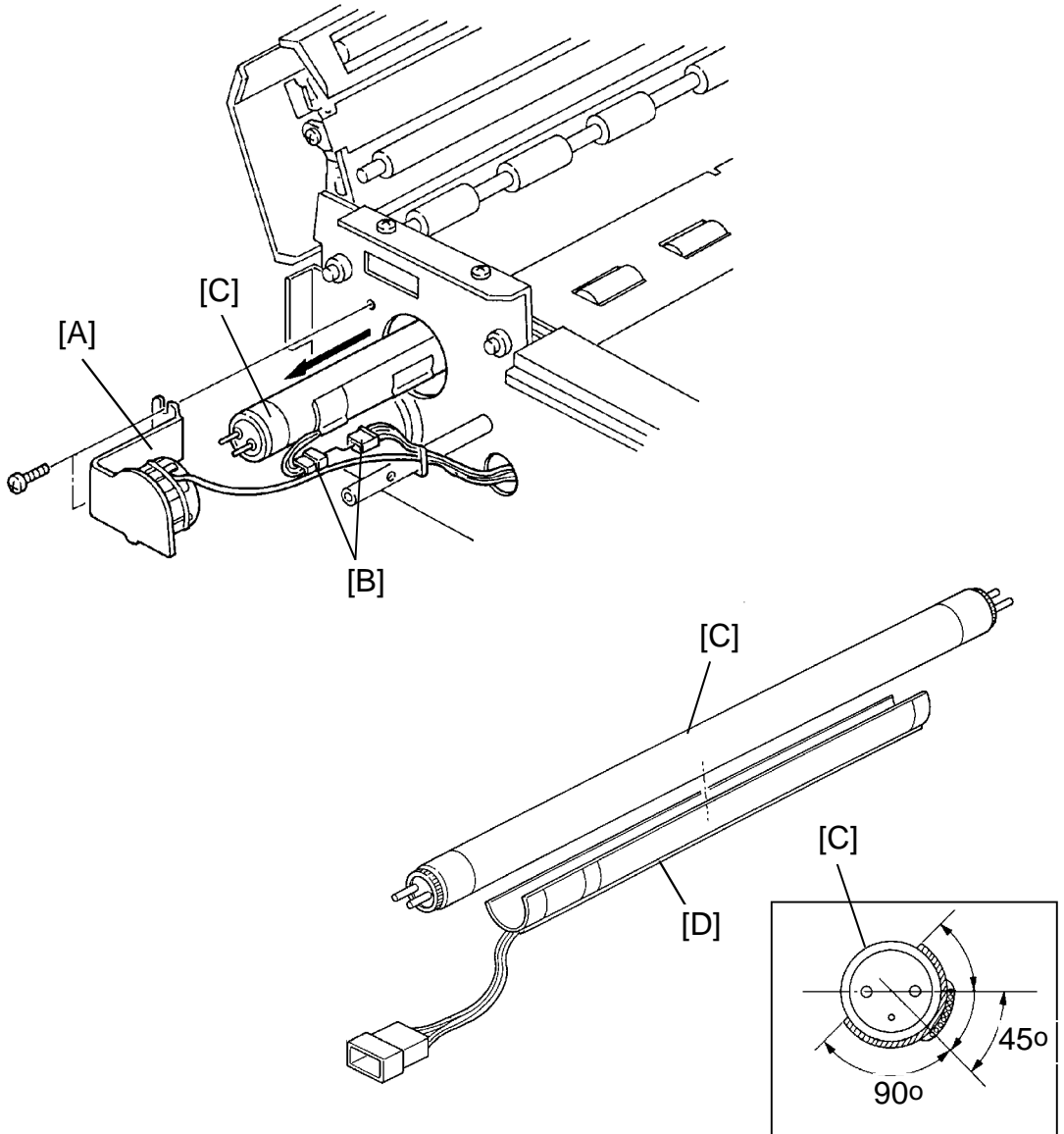

1. Slide the scanner unit to the left.
2. Remove the front fluorescent lamp cover (2 screws).
3. Remove the front fluorescent lamp holder [A] (2 screws).
4. Disconnect the 4P heater connector [B].
5. Carefully remove the fluorescent lamp [C] so that it does not contact the exposure glass.
6. Remove the heater [D] from the fluorescent lamp.

## 2.6 ORIGINAL REGISTRATION SENSOR / 2ND ORIGINAL SENSOR REPLACEMENT

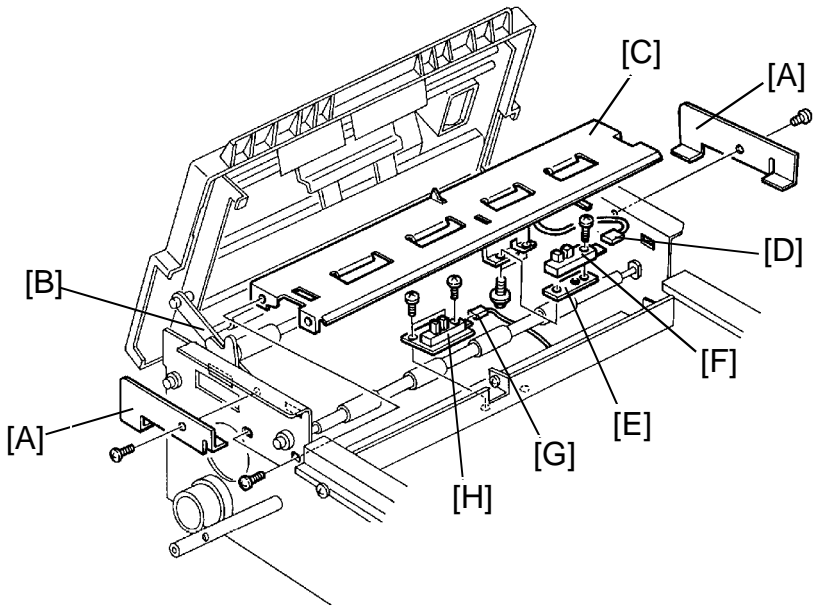

### Original Registration Sensor:

1. Remove the DF unit stoppers [A] (VT2100/VT2130/VT2150 only).
2. Remove the exposure glass. (See page 5-6.)
3. Remove the fluorescent lamp. (See page 5-6.)
4. Remove the screw securing the stopper [B] (VT2300/VT2500 only).
5. Remove the guide plate [C] (4 screws).
6. Disconnect the original registration sensor connector [D].
7. Remove the sensor with the securing plate [E] (2 screws).
8. Remove the original registration sensor [F] from the securing plate.

### 2nd Original Sensor:

1. ~ 5. procedures are the same as above.
6. Remove the original table. (see page 5-2.)
7. Remove the 2nd original sensor feeler.
8. Disconnect the 2nd original sensor connector [G].
9. Remove the 2nd original sensor [H] (2 screws).

## 2.7 1ST ORIGINAL SENSOR REPLACEMENT: VT2300/2500

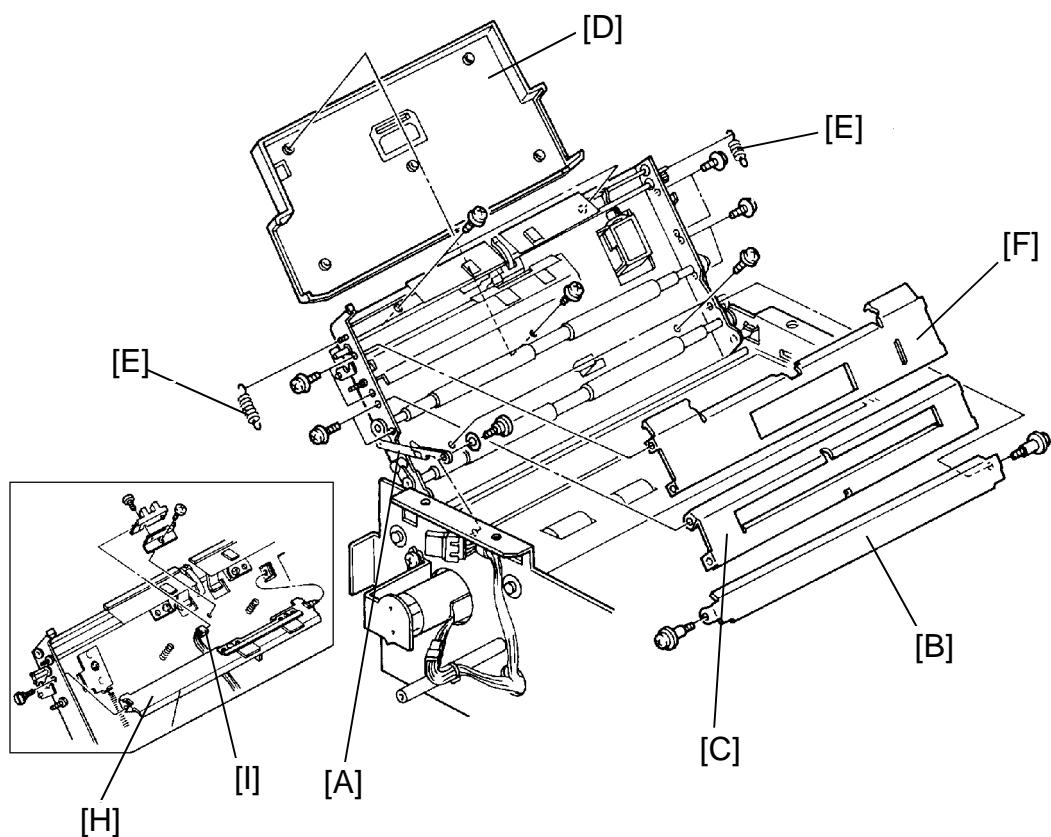

1. Remove the screw securing the stopper [A] (1 screw).
2. Remove the platen plate [B] (2 screws).
3. Remove the original guide [C] (4 screws).
4. Remove the ADF unit cover [D] (5 screws).
5. Unhook the both hook springs [E].
6. Remove the separation guide plate [F] (4 screws).
7. Remove the separation blade assembly [H] (1 screw).
8. Disconnect the 1st original sensor connector [I].
9. Remove the sensor from the sensor bracket.

## 2.8 ORIGINAL FEED ROLLERS / PULL-OUT ROLLERS REPLACEMENT: VT2300/2500

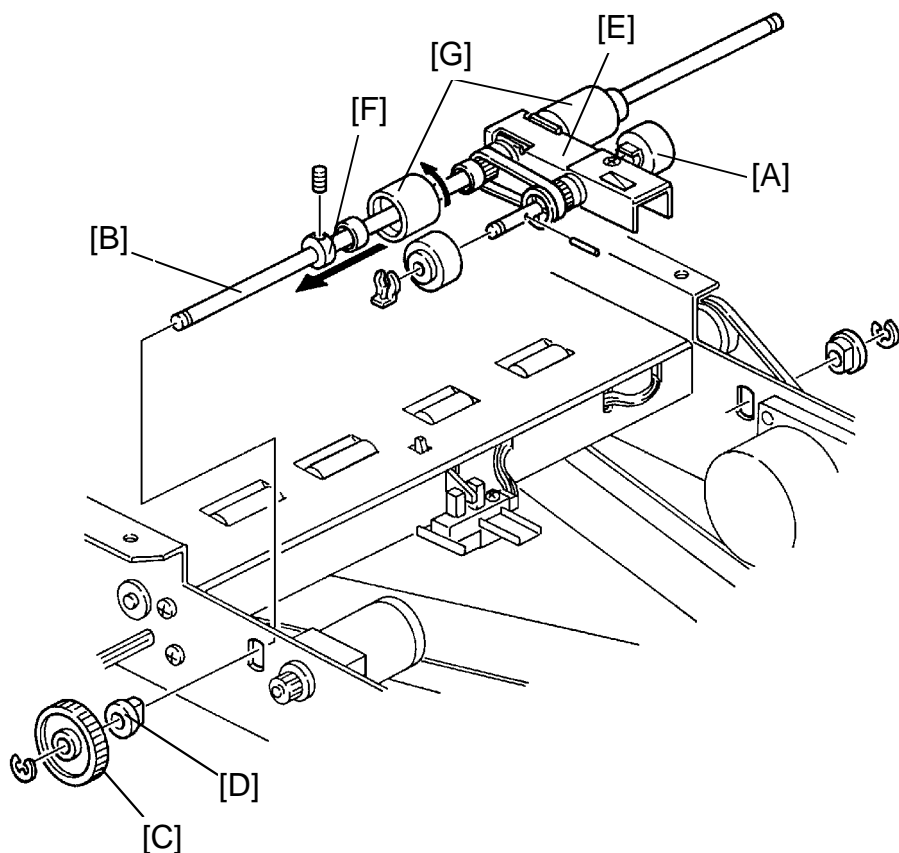

1. Remove the original table (See page 5-2).
2. Replace the pull-out rollers [A] (1 snap ring, 1 pin).
3. Remove the E-rings at the both end of the original feed roller shaft [B].
4. Remove the ADF drive gear [C] and bushing [D].
5. Remove the original feed roller assembly [E].
6. Remove the stopper [F] (Allen screw).
7. Replace the original feed rollers [G].

**NOTE:** A one-way clutch is installed in the feed roller. Confirm that the roller can rotate in the arrow direction as shown in the above illustration.

## 3. SCANNER SECTION

### 3.1 OPTICAL ADJUSTMENT

The only change in the optical adjustment procedure is that black level adjustment should be done first.

The following table shows the reciprocal relationship between adjustment procedures. When the items listed in the left column are adjusted, the items listed in the top row must also be adjusted.

Adjustment Items	Black Level (VT2300/ VT2500)	White Level	Shading	Scan Line Position	Reading Start Position of Main Scan	Focus (MTF)	Reduction Ratio (Moire)
Black Level (VT2300/VT2500)		○	○			○	○
White Level							
Shading	○	○					
Scan Line Position		○	○		○		
Reading Start Position of Main Scan		○	○	○			
Focus (MTF)							○
Reduction Ratio (Moire)	○	○	○	○	○	○	

The facsimile test chart R-21 (P/N 99992131) and an oscilloscope are required for this adjustment.



### 3.1.1 Preparation for Adjustment

1. Remove the original table cover.
2. Connect the terminals of the oscilloscope to the following test pins on the A/D Conversion PCB.

VT2100/VT2130/VT2150		VT2300/VT2500	
Terminal	Test Pin	Terminal	Test Pin
Channel 1	TP 600	Channel 1	TP 601
Channel 2	TP 603	Channel 2 (Black Level Standard Voltage)	TP 600
GND	TP 602	GND	TP 604

\* The trigger terminal is TP 603.

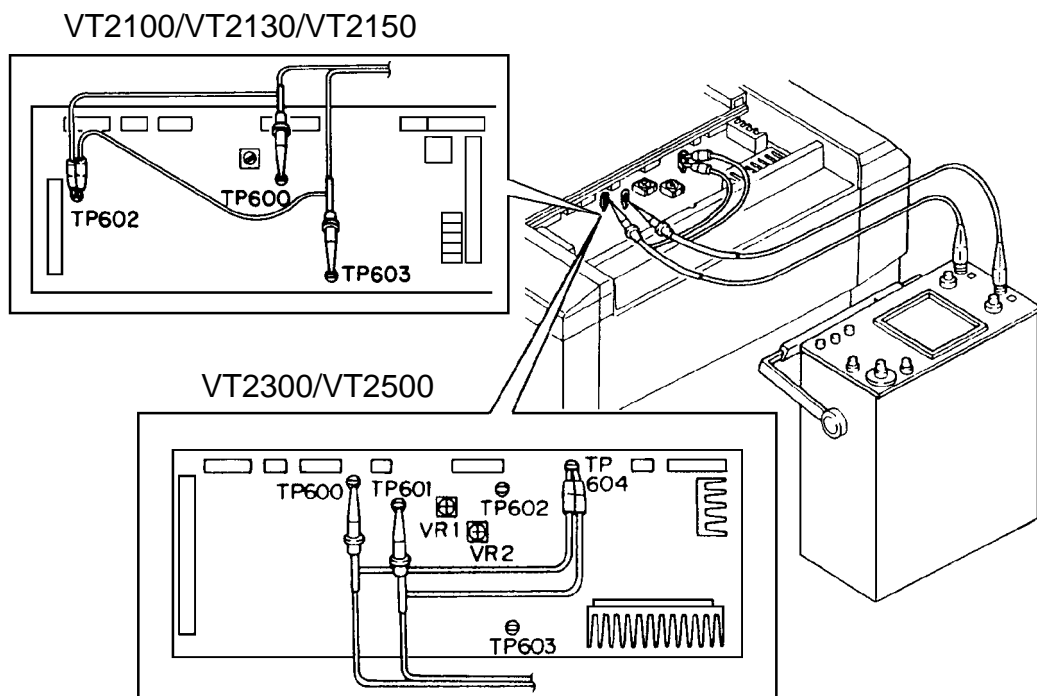

3. Turn on the power switch while holding down the Print Start key, Stop key and Clear key on the operation panel. --- **LT version only**  
Turn on the power switch while holding down the Print Start key, Stop key, Clear key and the Full Master Detecting switch. --- **A4 version only**
4. Set "15" in the copy counter and set "0" in the memory/class display to turn on only the fluorescent lamp.

### 3.1.2 Black Level Adjustment: VT2300/VT2500

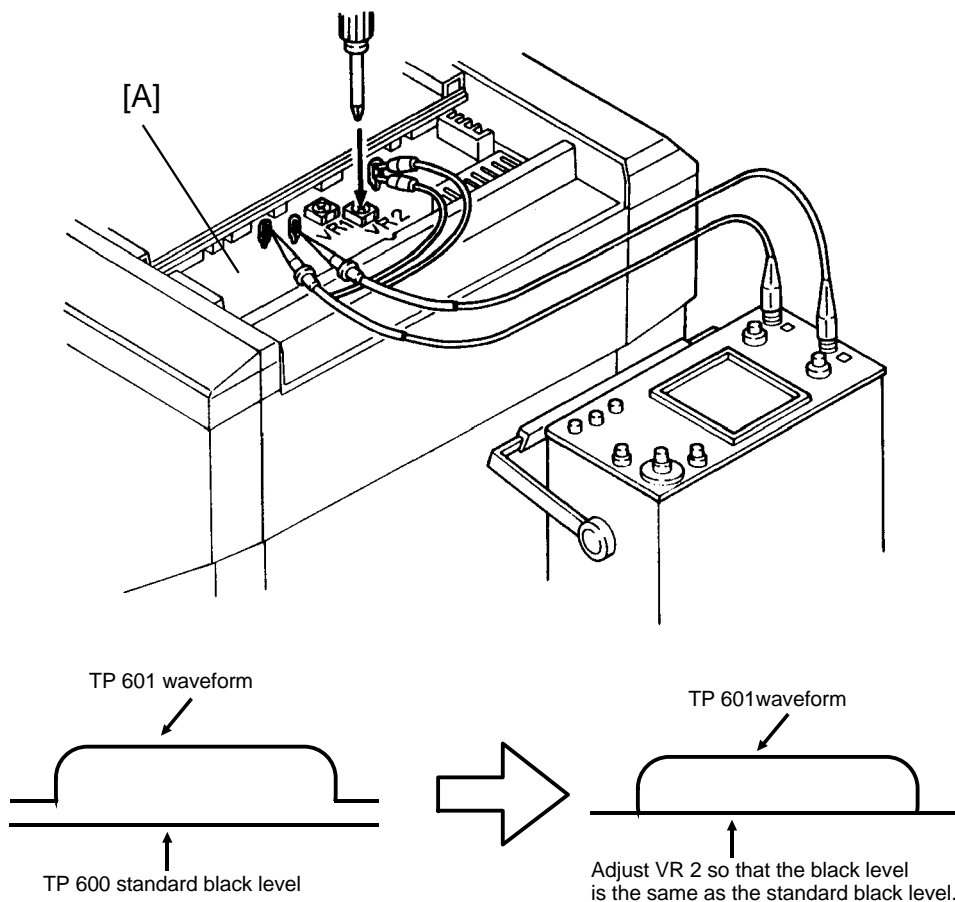

**Purpose:** To ensure that the black level from the CCD output conversion/amplification board is the same as the standard black level (1.4 V).

1. Close the scanner unit.
2. Press the Print Start key to turn on the fluorescent lamp.
3. Confirm that the black level at TP 601 is the same as the standard black level (1.4 V) at TP600 on the A/D conversion board [A].
4. If the black levels are not the same, adjust VR2 to set the black level at TP601 to the standard black level (1.4±0.03 V).

### 3.1.3 Shading Adjustment

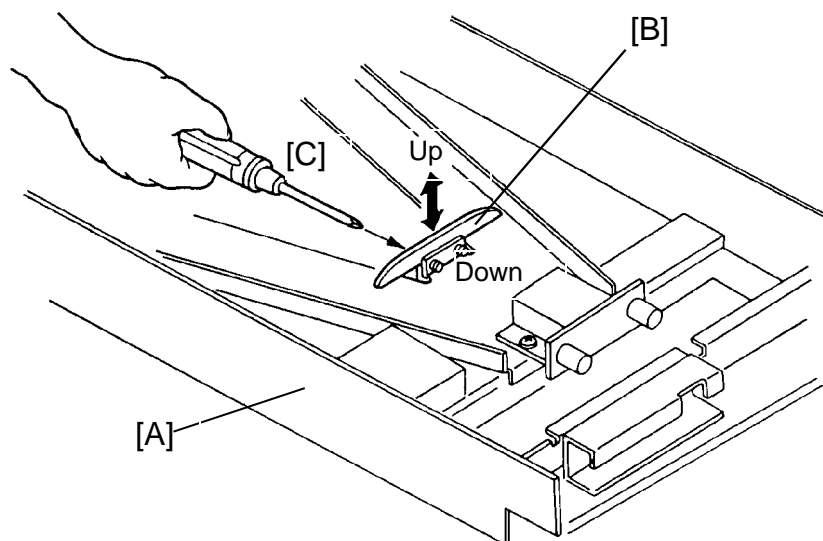

The middle of the waveform  
should be higher than the ends.

$$B \geq 0.6A$$

**Purpose:** To flatten the white level waveform. This also, corrects for distortion to the light intensity due to the output characteristics at both lamp ends and aberrations within the lens section.

1. Close the scanner unit [A].
2. Press the Print Start key to turn on the fluorescent lamp.
3. Confirm that the above white level waveform is displayed.
4. If incorrect, move the shading plate [B] position vertically (up or down), so that the waveform is similar to the one above.
5. After adjustment, retighten the mounting screws [C] of the shading plate [B].

### 3.1.4 Scan Line Position Adjustment

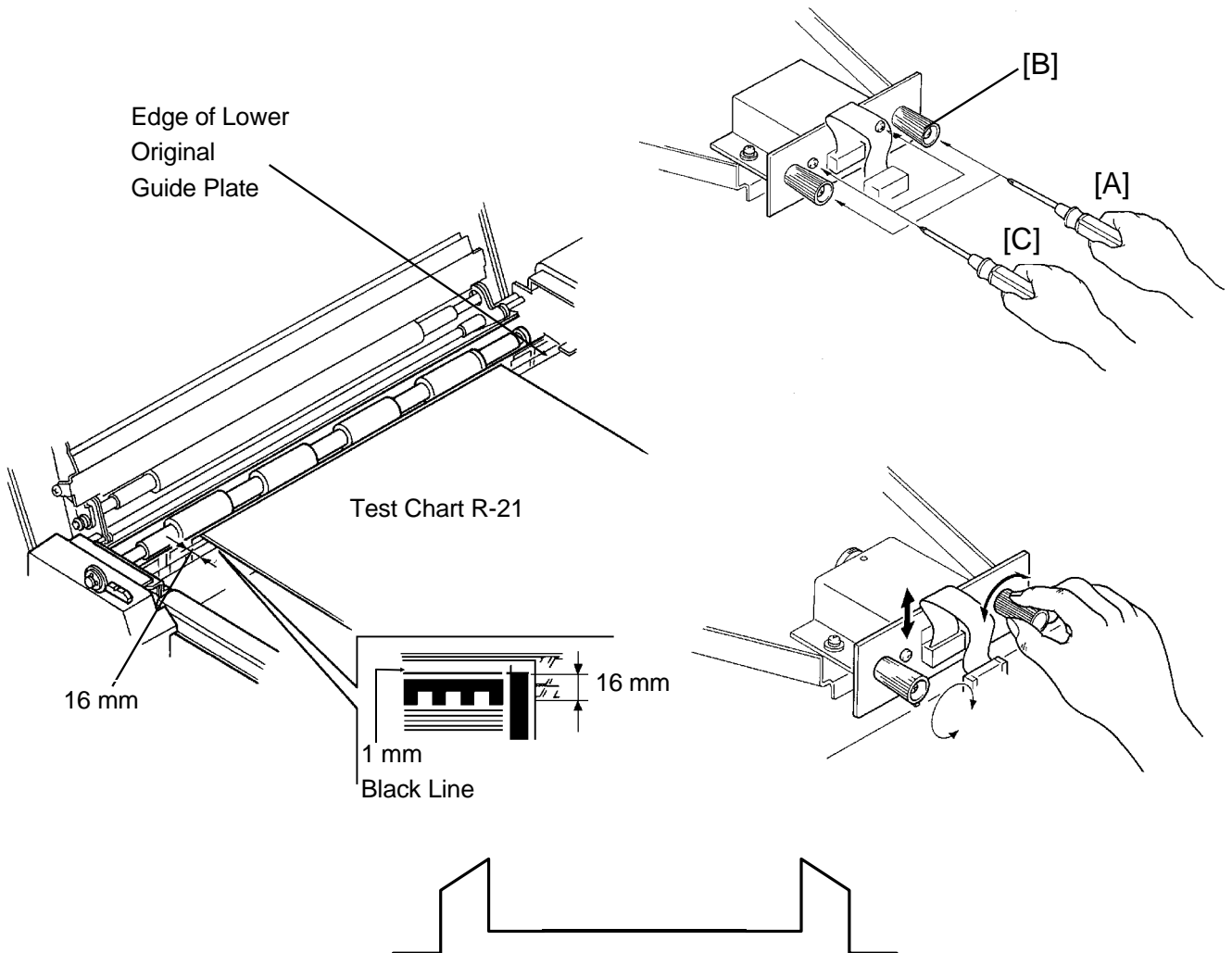

Purpose: To ensure that CCD alignment is perpendicular to the original feed direction.

1. Set the test chart so that the black line is positioned 16 mm away from the edge of the lower original guide plate as shown.
2. Press the Print Start key to turn on the fluorescent lamp and confirm that the waveform is similar to the above illustration.
3. If incorrect, loosen the mounting screws [A] fixing adjusting knob [B] and the mounting screws [C] of the CCD board and adjust the CCD position by turning the adjusting knob.
4. Tighten the mounting screws [B] and [C]. Then reconfirm the waveform.

### 3.1.5 Reading Start Position Adjustment (In The Main Scan Direction)

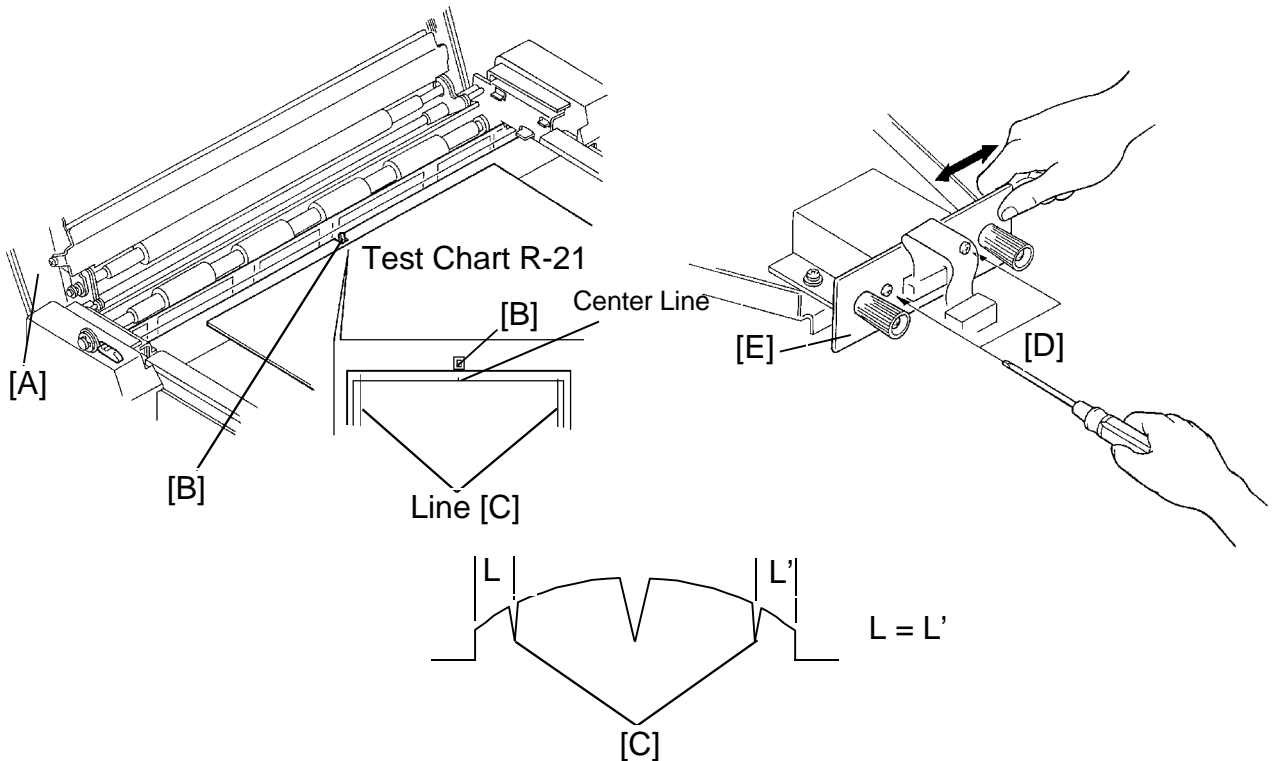

Purpose: To align the center of the original with the center of the CCD so that the center of original image is positioned in the center on the master.

1. Open the scanner unit [A].
2. Set the test chart so that the center line, located at the leading edge of the test chart, is positioned above the original leading edge sensor actuator [B].
3. Close the scanner unit [B].
4. Press the Print Start key to turn on the fluorescent lamp and feed the test chart.
5. Stop feeding the test chart when it is possible to read both lines [C], and confirm that the above waveform is displayed (The distance "L" is the same as "L'").
6. If incorrect, loosen the mounting screws [D] of the CCD board [E] and adjust the CCD horizontal position.
7. After adjustment, retighten the mounting screws.

### 3.1.6 Focus Adjustment (MTF Adjustment)

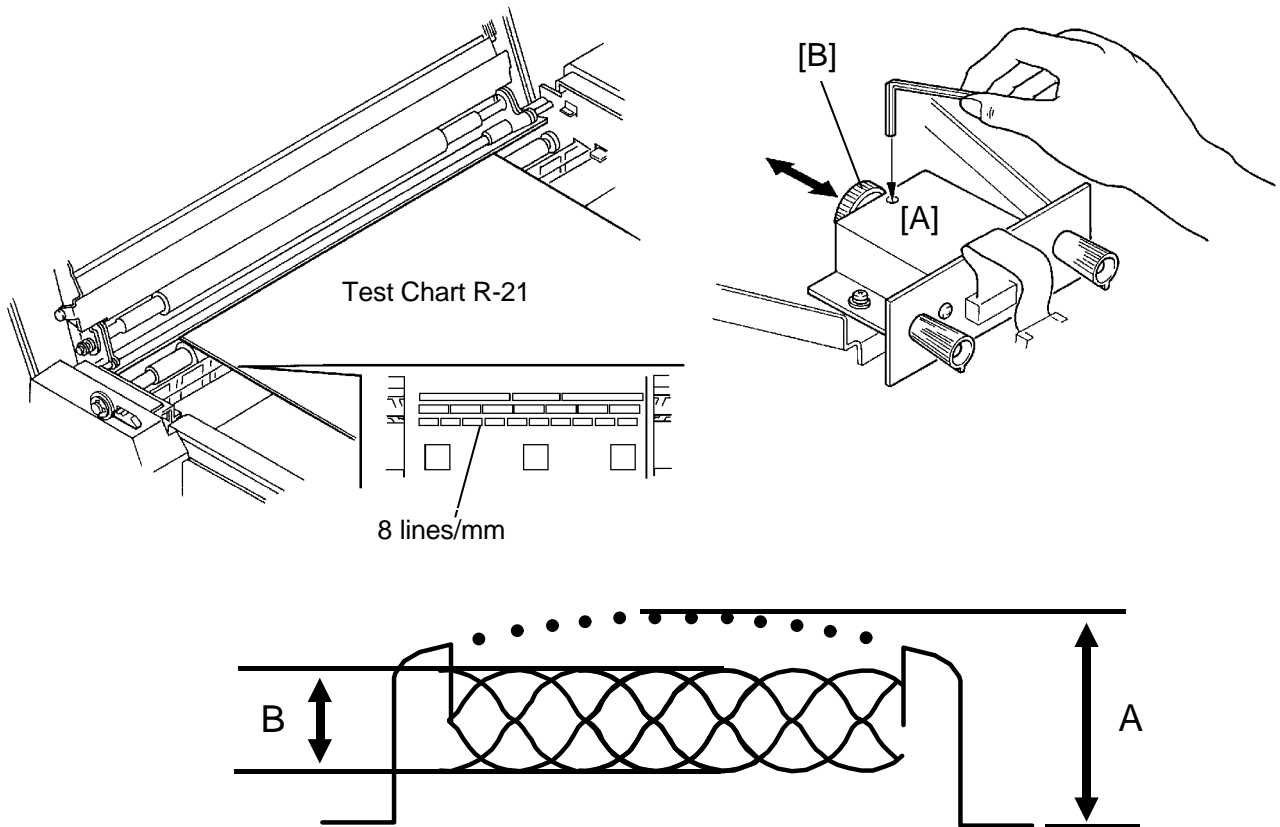

- $\frac{B}{A} \times 100 \geq 48\%$
- Amplitude "B" (difference between white and black levels) must be a maximum

Purpose: To focus the lens (focus distance between the CCD and the lens).

1. Position the test chart so that the 8 lines/mm section on the test chart can be read.
2. Press the Print Start key to turn on the fluorescent lamp.
3. Confirm that the wave form is similar to the above illustration.
4. If incorrect, loosen the allen screw [A] and adjust the lens position [B] by moving it as shown by the arrow.
5. After adjustment, retighten the allen screw.

### 3.1.7 Reduction Ratio Adjustment (Moire Adjustment)

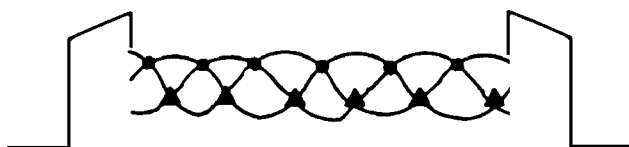
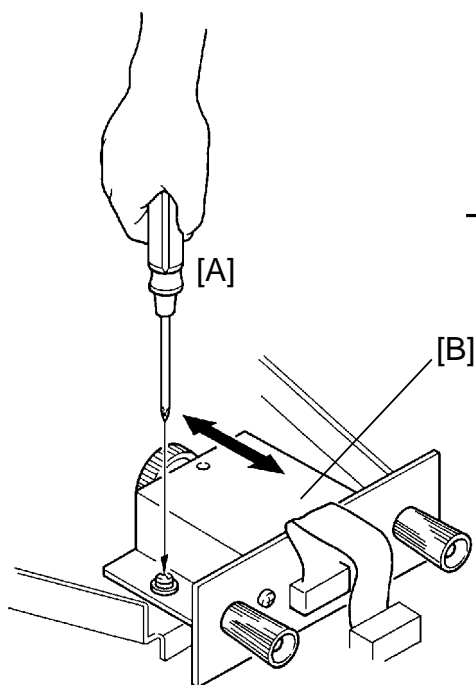

Cross points must be less than 6.

- : Upper cross points  $\leq 6$
- ▲ : Lower cross points  $\leq 6$

Purpose: To adjust the focus (to set distance between the lens and the original)

1. Position the test chart so that the area containing 8 lines/mm on the test chart can be read (See page 5-17).
2. Press the Print Start key to turn on the fluorescent lamp.
3. At the same time, confirm that the waveform is similar to the above illustration.
4. If incorrect, loosen the mounting screws [A] and adjust the lens block [B] position as indicated by the arrows.
5. After adjustment, retighten the mounting screw [A].

### 3.1.8 White Level Adjustment

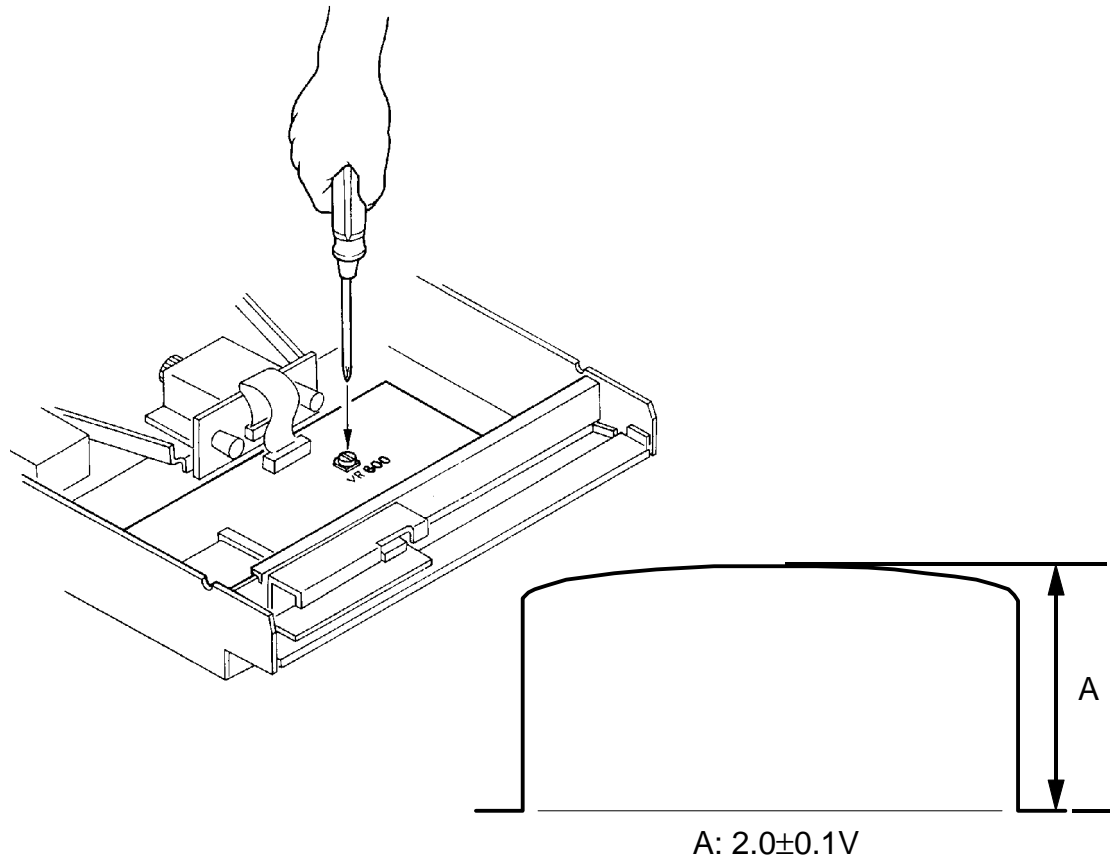

**Purpose:** To set the white level so that the background of the test chart is not copied.

1. Position the test chart so that the background area (white area) of the test chart can be read.
2. Press the Print Start key to turn on the fluorescent lamp.
3. Adjust VR 600 for VT2100/VT2130/VT2150 (VR-1 for VT2300/VT2500) on the A/D conversion PCB so that the maximum level is  $2.0 \pm 0.1$  V.



## 3.2 IMAGE MAGNIFICATION ADJUSTMENT (In The Sub-scan Direction)

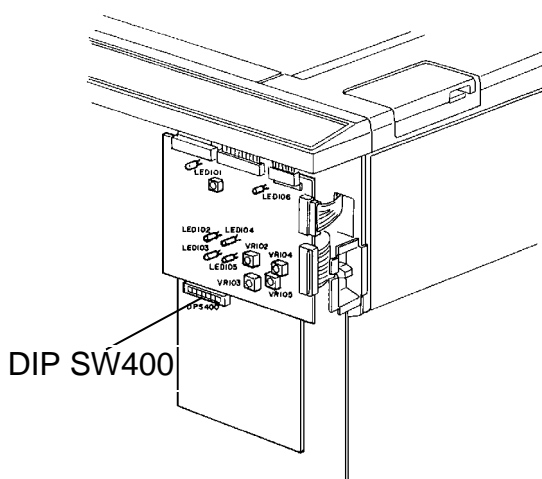

Purpose: To ensure that the image magnification lengthwise is  $100\% \pm 0.5\%$  when using the full size mode.

1. Press the Full Size (100 %) key.
2. Make prints of the test chart.
3. Make sure that the image length is  $100\% \pm 0.5\%$  by comparing the prints with the test chart.
4. If the prints are not within specification, open the front cover of the machine and adjust the magnification ratio using DIP SW400 on the image processing board.

<DIP SW / Correction Ratio>

	DIP 400-1	DIP 400-2	DIP 400-3	$\text{Zoom Ratio} = \frac{(\text{Length of Test Chart})}{(\text{Length of Print Image})} \times 100$
Red:	OFF	OFF	OFF	100 %
	OFF	ON	OFF	99.25 %
	OFF	OFF	ON	98.77 %
	OFF	ON	ON	98.25 %
Enl:	ON	OFF	OFF	100 %
	ON	ON	OFF	100.75 %
	ON	OFF	ON	101.23 %
	ON	ON	ON	101.75 %

## 4. IMAGE SHIFTING SECTION

### 4.1 ENCODER MOUNTING POSITION ADJUSTMENT

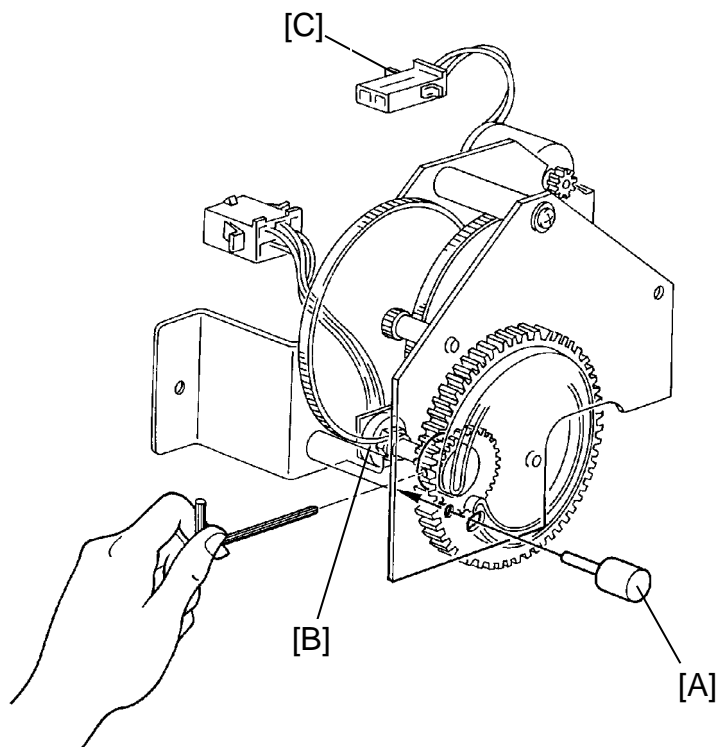

Purpose: To ensure that the image is positioned in the middle when the Image Shifting key is set at the center "0".

1. Remove the rear cover of the machine.
2. Turn on the power switch and press the "--" Image Shifting key to shift the position to the maximum backward position ("–2" position ). After that, press "+" Image Shifting key to shift the position to the center (when the "0" position LED lights).
3. Make sure that it is possible to insert the image shifting position gauge [A] to confirm gear alignment and, therefore, the image shifting position.
4. If incorrect, adjust the gear alignment as follows after removing the encoder [B]:

**CAUTION: Adjust the encoder position after removing the connector [C] of the image shift motor.**

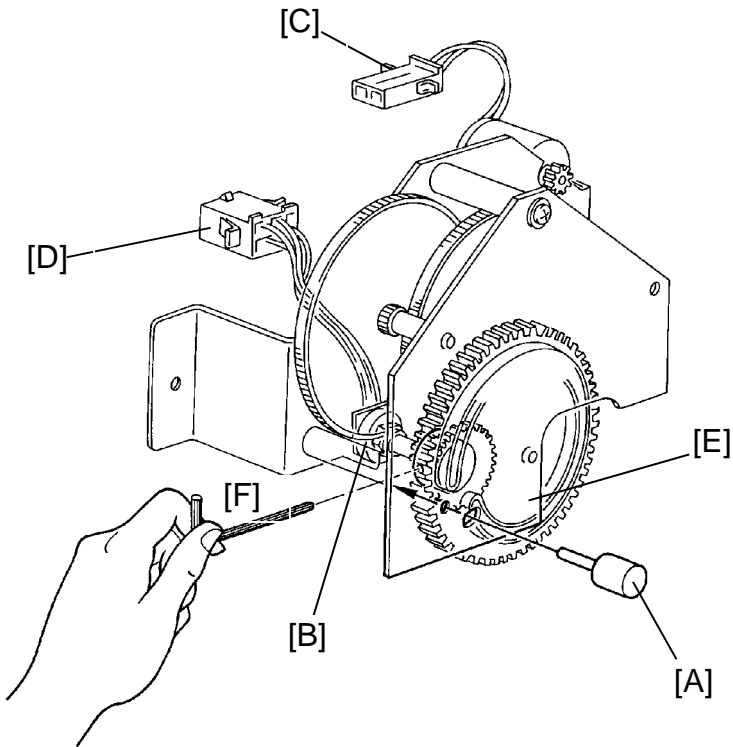

5. Disconnect the connector [D] of the encoder.
6. Insert the gauge [A] into the hole of the gear [E].
7. Turn on the LED "--2" of the Image shift indicator on the operation panel. Then gradually turn the shaft of the encoder [B] in the "0" position direction and stop it as soon as the "0" position LED lights.
8. In the above condition, set the encoder and tighten the allen screw [F] to mount the shaft of the encoder with the gear [E]. Then remove the gauge [A] and connect the connector [C] of the image shift motor.
9. After adjustment, make prints to confirm the image position.

## 5. MASTER FEED SECTION

### 5.1 THERMAL HEAD VOLTAGE ADJUSTMENT

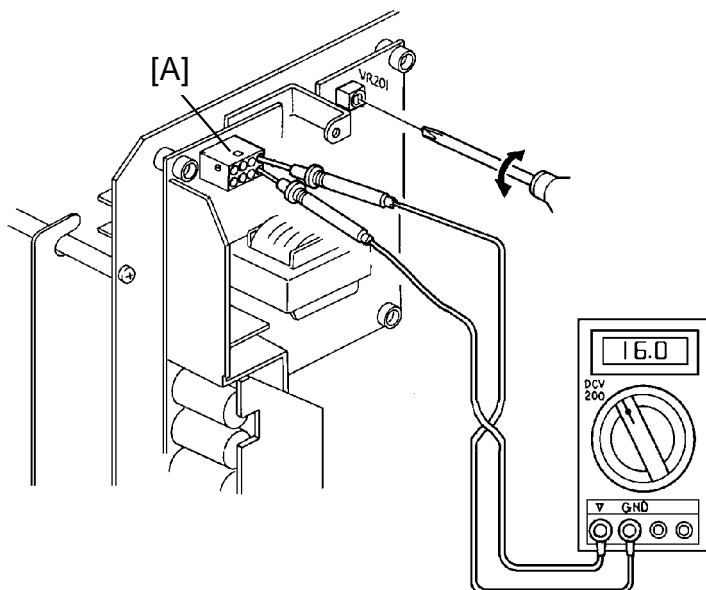

**Purpose:** To maintain master making quality and extend the lifetime of the thermal head.

**NOTE:** This adjustment is always required when the thermal head or power supply PCB is replaced.

1. Remove the rear cover of the machine.
2. Check the voltage noted on the decal, located on the thermal head. (The voltage varies according to the individual thermal head.)
3. Disconnect CN-504 [A] of the power supply PCB.
4. Place the master between the platen roller and the thermal head to protect the thermal head.
5. Access I/O check mode. (See page 4-11.)
  - Enter "0" in the memory display and "35" in the copy counter  
---- VT2300/VT2500 only
  - Enter "0" in the memory display and "34" in the copy counter  
---- VT2100/VT2130/VT2150 only
6. Press the Print Start key to apply the thermal head voltage.
7. While holding down the Print Start key, Confirm that the voltage between pins 3 and 6 on CN504 is at the level specified on the decal (Within +0V, -0.1V).
8. If it is not, adjust VR201 on the power supply board.

## 5.2 BELT TENSION ADJUSTMENT

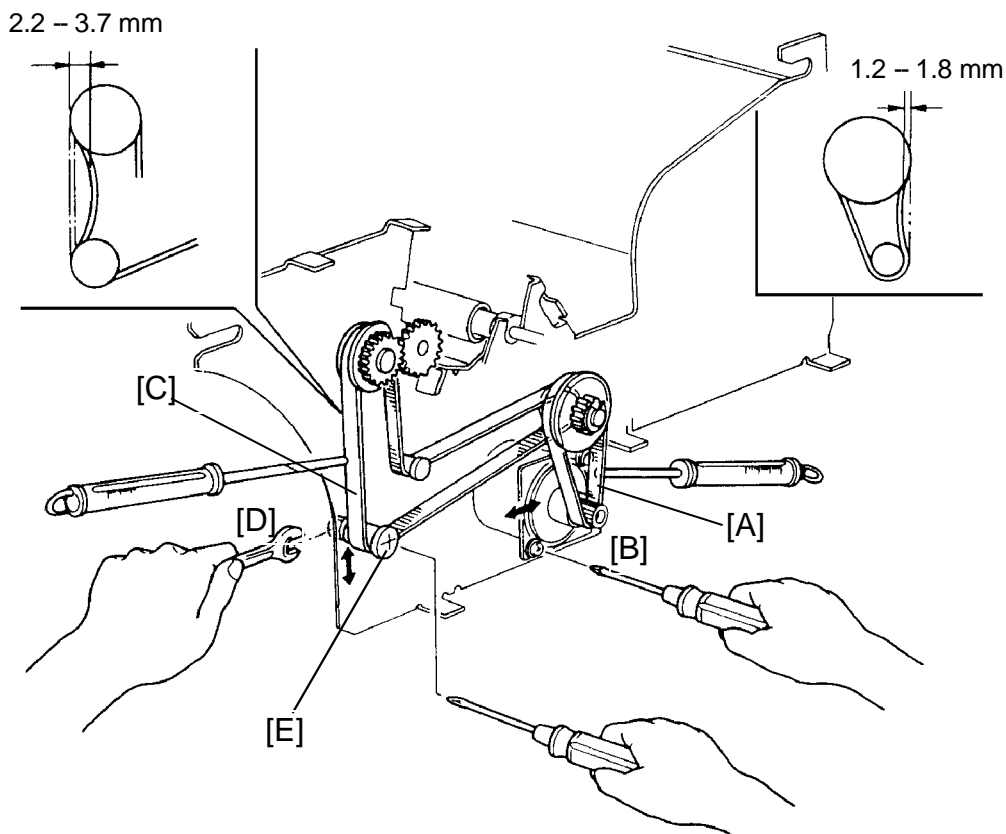

**Purpose:** To ensure that correct master feed motor rotation is transmitted to each roller.

### **Platen Roller Drive Belt:**

1. Turn off the main switch.
2. Remove the master feed unit from the machine.
3. Using a tension gauge, apply a 110-gram load to the center of the belt [A]. Make sure that the belt deflects 1.2 to 1.8 mm.
4. If incorrect, adjust the belt tension by raising or lowering the master feed motor [B].

### **Feed Roller Drive Belt:**

5. Using a tension gauge, apply a 110-gram load to the center of the belt [C]. Make sure that the belt deflects 2.2 to 3.7 mm.
6. If incorrect, loosen the nut [D] and adjust the belt tension by raising or lowering the tensioner [E].

## 5.3 RIGHT AND LEFT CUTTER SWITCH ADJUSTMENT

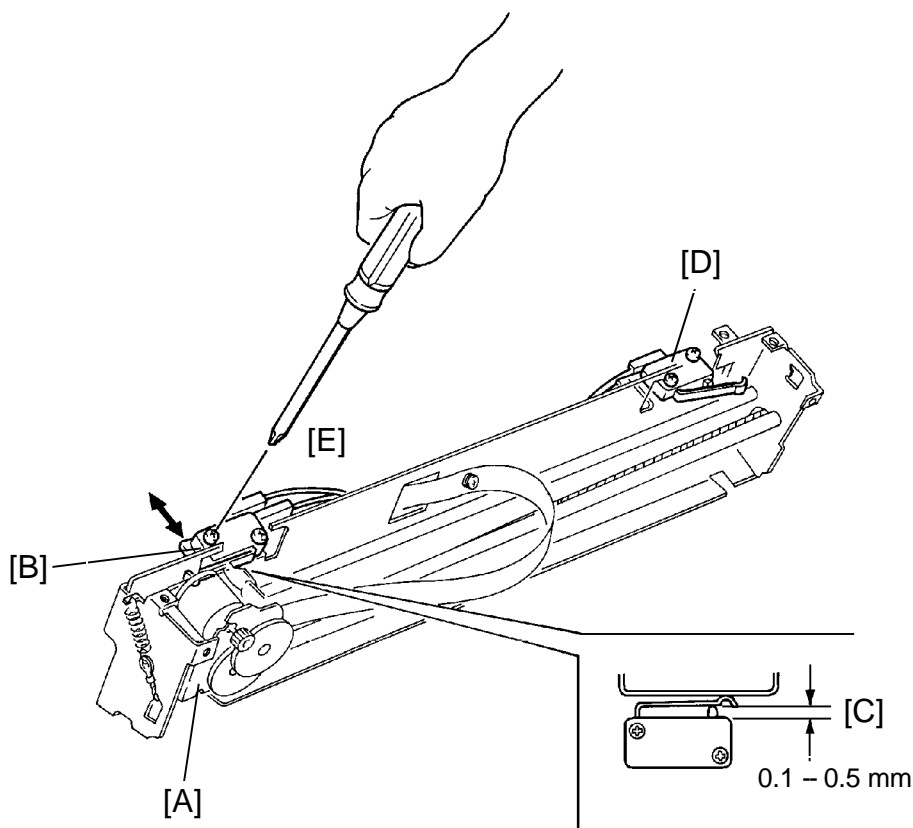

Purpose: To ensure that the cutter slider stops properly.

1. Turn off the main switch.
2. Remove the cutter unit (2 screws).
2. Remove the cutter unit cover (4 screws).
4. After moving the cutter slider [A] fully to the left, make sure that the left cutter switch [B] is turned on and that the switch stroke [C] is 0.1 to 0.5 mm. Also, make sure that the right cutter switch [D] is actuated in the same fashion.
5. If incorrect, loosen the mounting screws [E] and adjust the switch position.

## 5.4 REVERSE ROLLER SOLENOID ADJUSTMENT

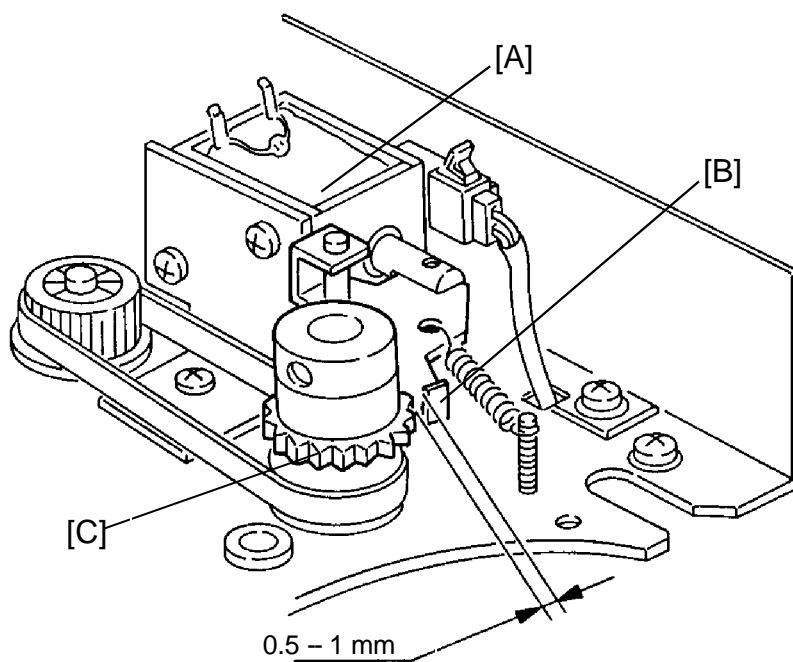

Purpose: To ensure proper operation of the reverse roller clutch.

1. Turn off the main switch.
2. Remove the master feed unit.
3. Adjust the solenoid [A] position so that there is 0.5 to 1 mm clearance between the stopper [B] and the gear [C] when the solenoid is energized.

## 5.5 CUTTER REPLACEMENT

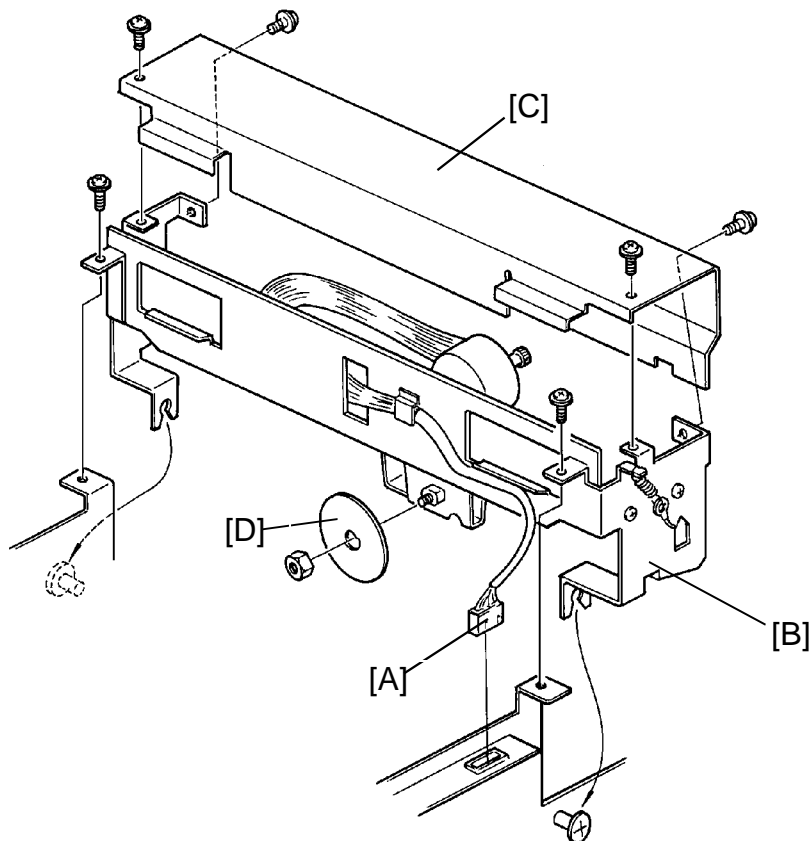

1. Turn off the main switch.
2. Slide the scanner unit to the left.
3. Disconnect the 6P connector [A].
4. Remove the cutter unit [B] (2 screws).
5. Remove the cutter unit cover [C] (4 screws).
6. Remove the lower cutter cover (2 screws).
7. Remove the cutter [D] (1 nut).

**NOTE:** When reassembling, move the cutter motor to the home position (operation side end) before the lower cutter cover is installed.

**CAUTION:** The edge of the cutter is very sharp.



## 5.6 MASTER BUCKLE SENSOR REPLACEMENT

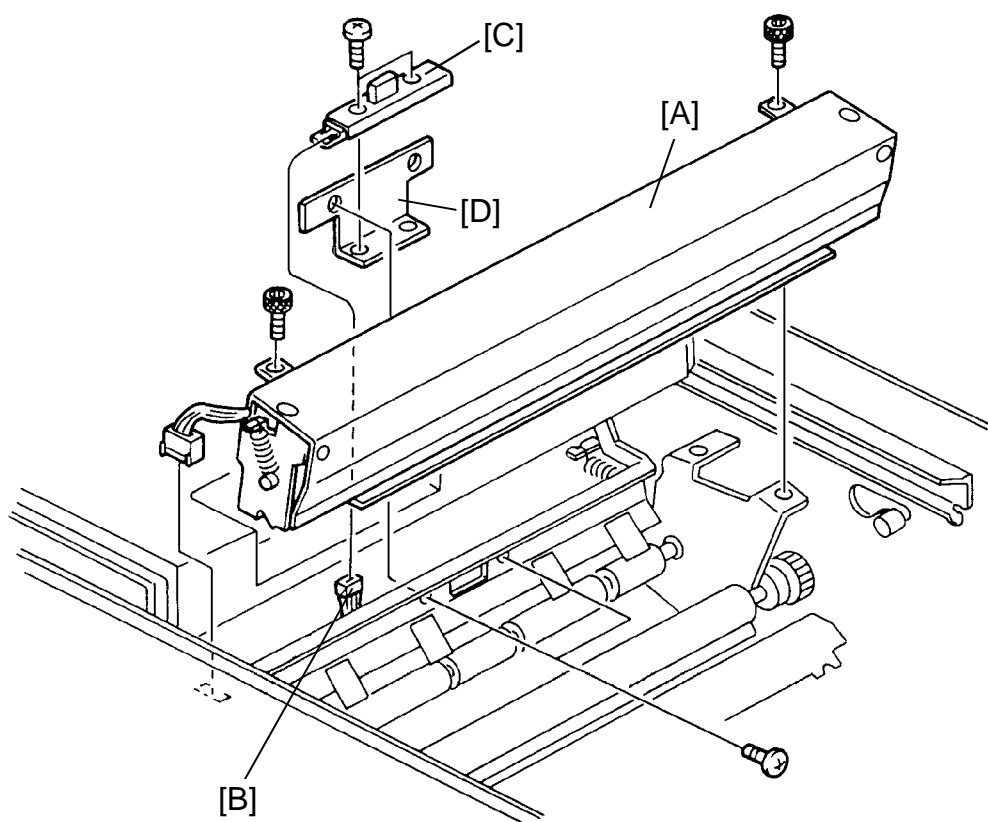

1. Turn off the main switch.
2. Slide the scanner unit to the left.
3. Remove the master roll.
4. Remove the cutter unit [A] (2 screws).
5. Disconnect the buckle sensor connector [B].
6. Remove the buckle sensor [C] together with the bracket [D] (2 screws).
7. Remove the buckle sensor from the bracket (2 screws).

## 5.7 THERMAL HEAD REPLACEMENT:

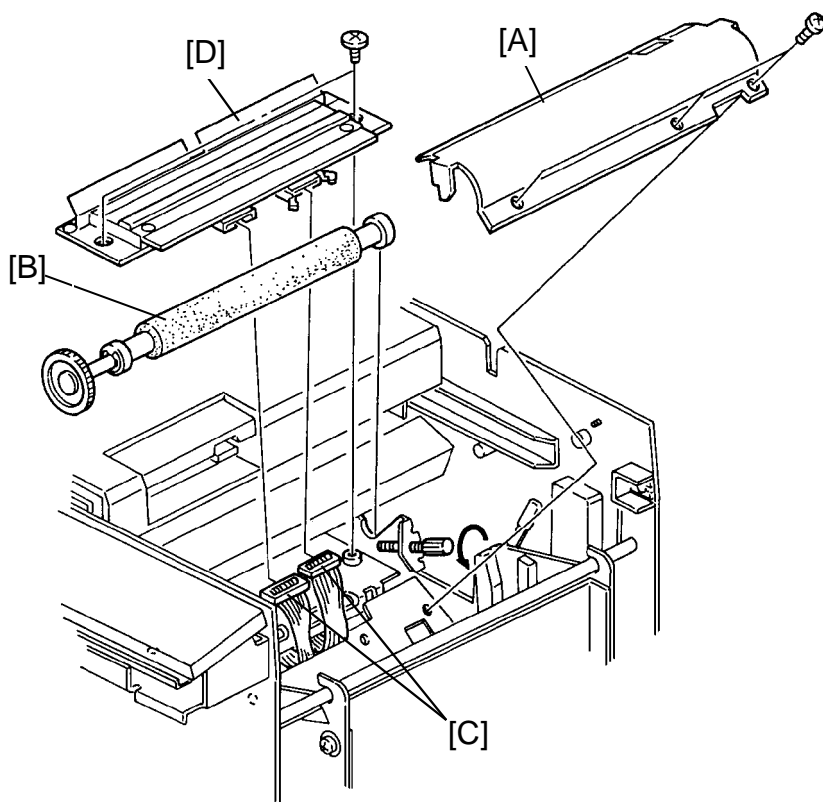

1. Turn off the main switch.
2. Slide the scanner unit to the left.
3. Remove the master roll.
4. Remove the thermal head cover [A] (3 screws).
5. Remove the platen roller [B] (2 knob screws).
6. Disconnect the thermal head connectors [C].
7. Remove the thermal head [D] (2 screws).
8. After installing the thermal head, adjust the thermal head voltage. (See page 5-23.)

- NOTE:**
- The thermal head type being used on the VT2000 series is different from those of SS900 series.
  - The VT2100/VT2300/VT2500 use the B4 size (256 mm width) thermal head (P/N C2138100)
  - The VT2130/VT2150 use the A4/LG size (216 mm width) thermal head (P/N C2118100)

## 5.8 THERMAL HEAD DRIVE BOARD REPLACEMENT

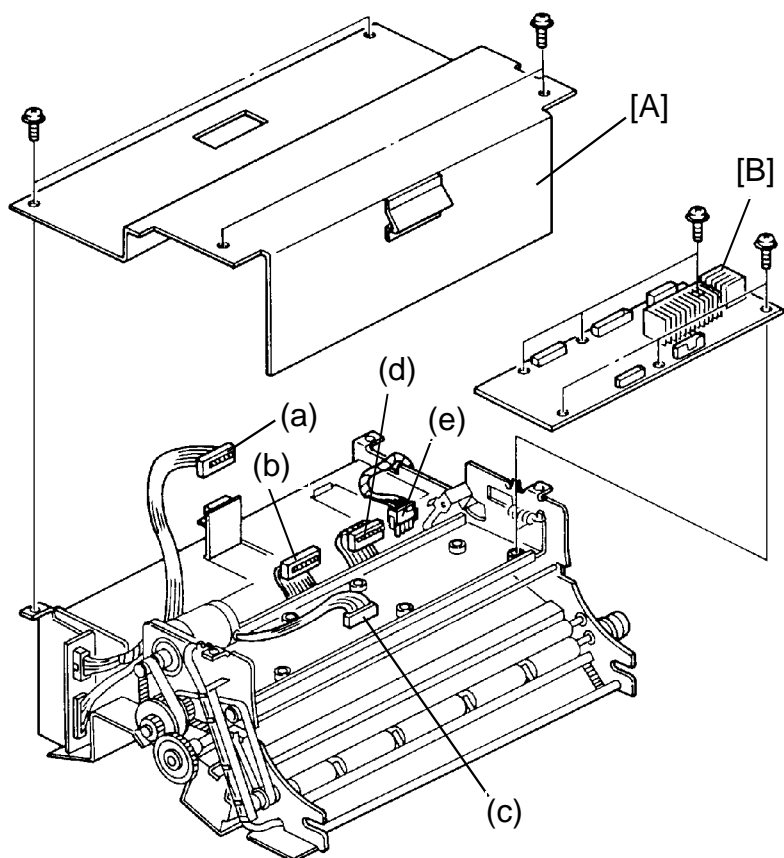

1. Turn off the main switch.
2. Remove the master feed unit from the machine.
3. Remove the bottom plate [A] of the master feed unit.
4. Disconnect the 5 connectors (a to e).
5. Remove the thermal head drive board [B] (6 screws).

## 6. MASTER EJECT SECTION

### 6.1 MASTER EJECT SOLENOID ADJUSTMENT

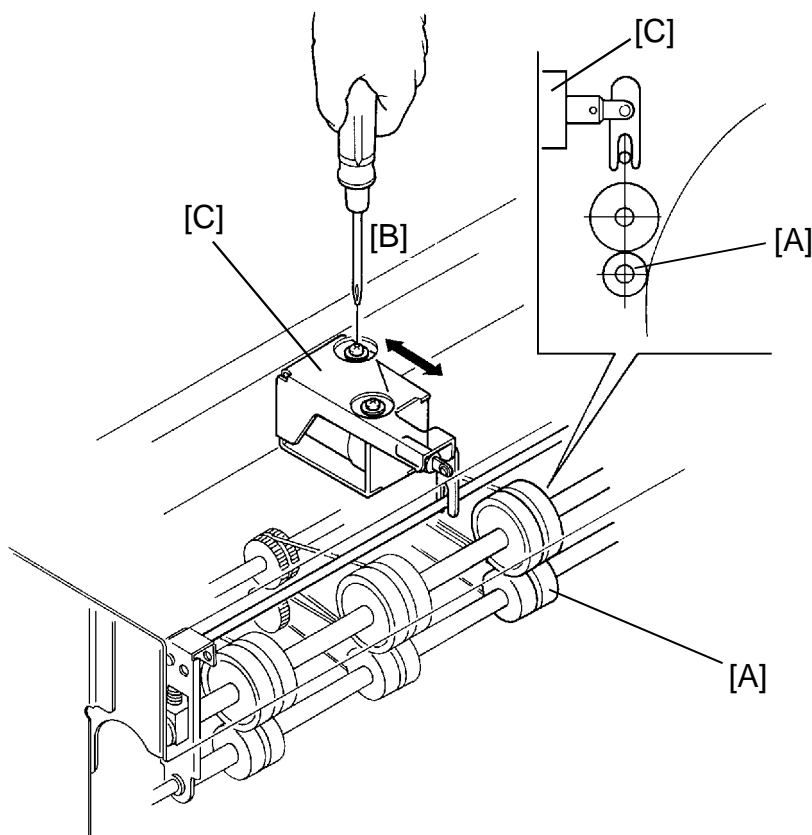

**Purpose:** To ensure that master is ejected.

1. Open the master eject unit and remove the upper cover of the master eject unit (4 screws).
2. Access I/O check mode (See page 4-11), and eEnter "0" in the memory display and "7" in the copy counter.
3. Press the Print Start key to turn on the master eject solenoid.
4. Confirm that the lower first eject rollers [A] are touched to the drum surface and also confirm that they are separated from the drum when the master eject solenoid turns off.
5. If it is out of adjustment, loosen the screws [B] and adjust the mounting position of the master eject solenoid [C].
6. After adjustment, retighten the screws [B].

**NOTE:** To easily confirm whether the lower roller touches to the drum surface. Wrap the drum with the blank paper. Check the paper for roller marks.

## 6.2 PRESSURE PLATE POSITION SWITCH ADJUSTMENT

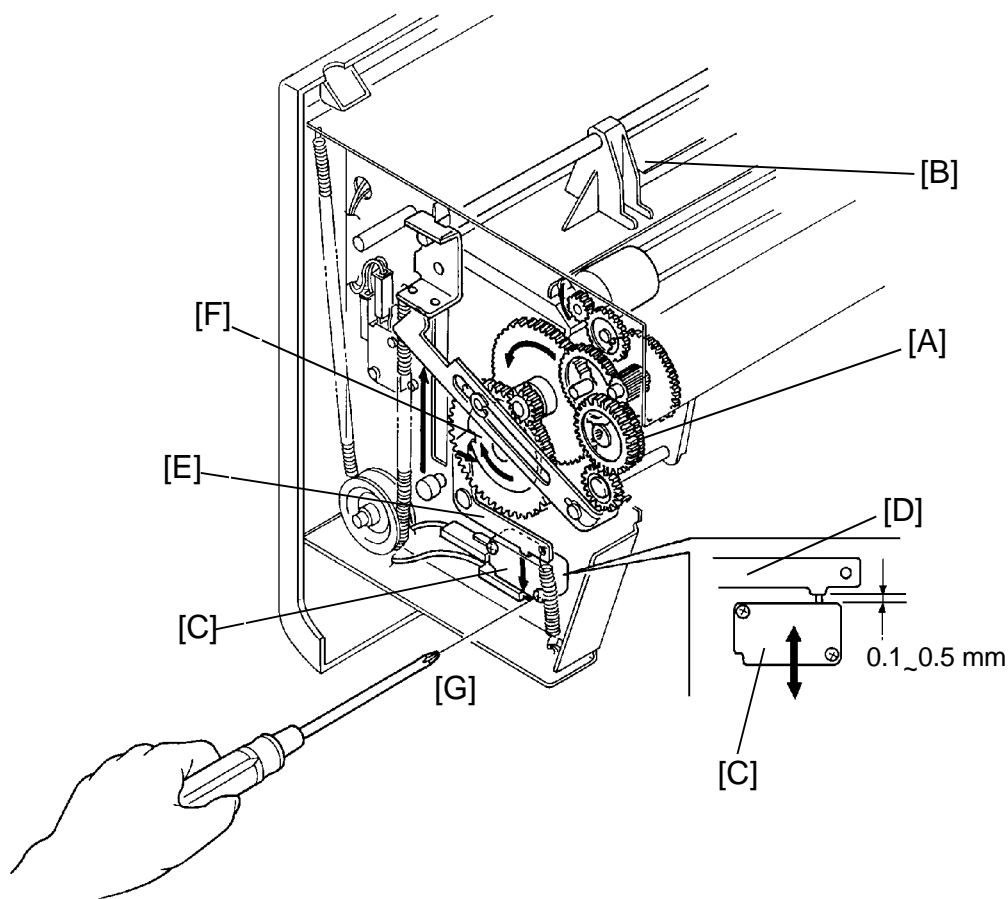

Purpose: To ensure that the pressure plate stops at the proper position.

1. Open the master eject unit and remove the front cover of the master eject unit (3 screws).
2. Turn the gear [A] and position the pressure plate [B] at the maximum height.
3. Confirm that the distance between the switch [C] and lever [D] is 0.1 to 0.5 mm when the lever edge [E] is positioned in the ditch on the cam [F] bottom.  
Also, confirm that the switch turns off when the lever edge [E] is not positioned in the ditch on the cam [F] bottom.
4. If it is out of adjustment, loosen the screws [G] and adjust the mounting position of the pressure plate position switch.

## 6.3 FULL MASTER SWITCH ADJUSTMENT

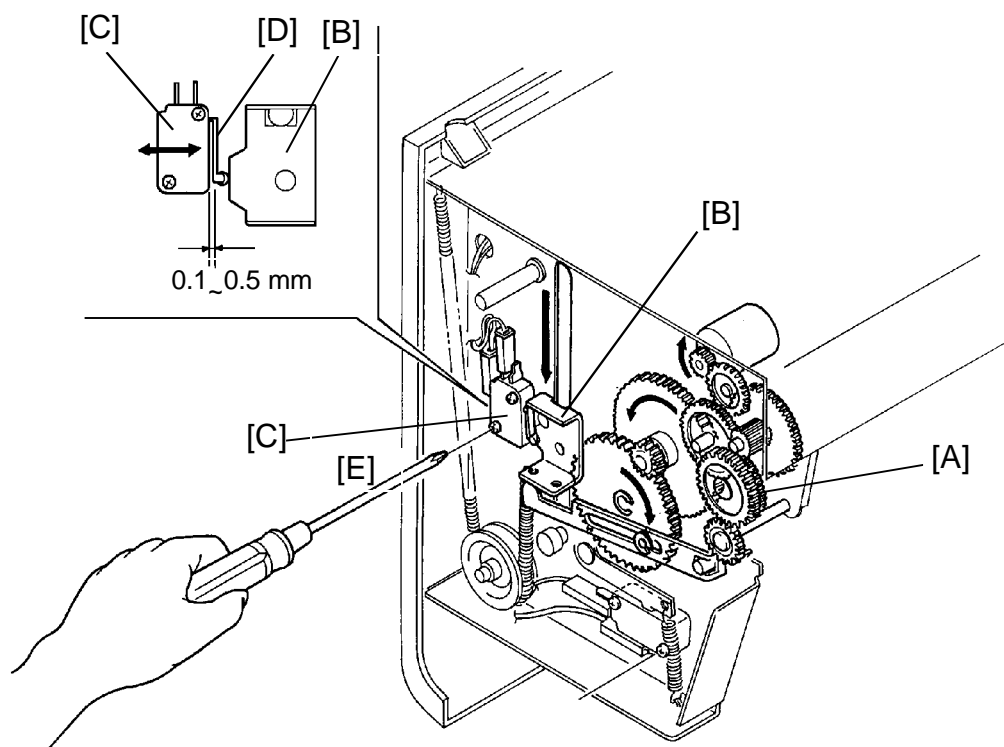

**Purpose:** To ensure that the full master detecting switch turns on when the master eject box is filled to capacity with ejected masters.

1. Open the master eject unit and remove the front cover of the master eject unit (3 screws).
2. Turn the gear [A] and position the pressure plate at its lowest position. Then, turn the gear further so that the arm [B] turns on the full master detecting switch [C].
3. Confirm that the distance between the full master detecting switch and the switch actuator [D] is 0.1 to 0.5 mm when the full master detecting switch turns on.
4. If it is out of adjustment, loosen the screws [E] and adjust the position of the full master detecting switch.
5. Tighten the mounting screws [E].

## 6.4 MASTER EJECT SENSOR ADJUSTMENT: VT2300/VT2500

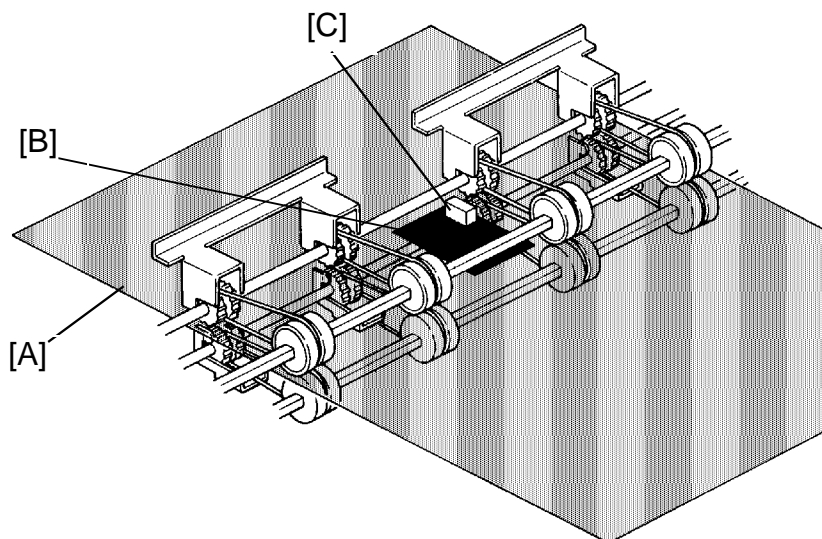

**Purpose :** To ensure that the sensor detects the ejected master.

1. Make a master that has a solid black area. The solid black area should be approx. A7 size (74 x 105 mm/3" x 4")
  - a. Set the original with the solid black area on the original table.
  - b. Press the Master Making key to make copies.
  - c. Stop printing when the image density of the solid black area on the copies stabilizes.
  - d. Remove the master from the drum.

**NOTE:** To prevent the thermal head from overheating, do not use a large solid black original.

2. Insert the above master [A] between the upper and the lower rollers with the master film side up and position the solid lack area under the sensor.
3. Confirm that the voltage between TP104 (MDLV) and the GND line (CN103-5) on the main control board [D] (see next page) is correct (4.0 V  $\pm$  0.5 V.)
4. If the voltage is outside the acceptable range, adjust it by turning VR104 on the main control board.

**NOTE:** Light reflected from an unused master has the highest intensity. Light reflected from that part of a used solid black master where the film layer has been burned away has the lowest intensity. Therefore, use a used solid black master for this adjustment so that the sensor can detect the ejected master under the worst conditions.

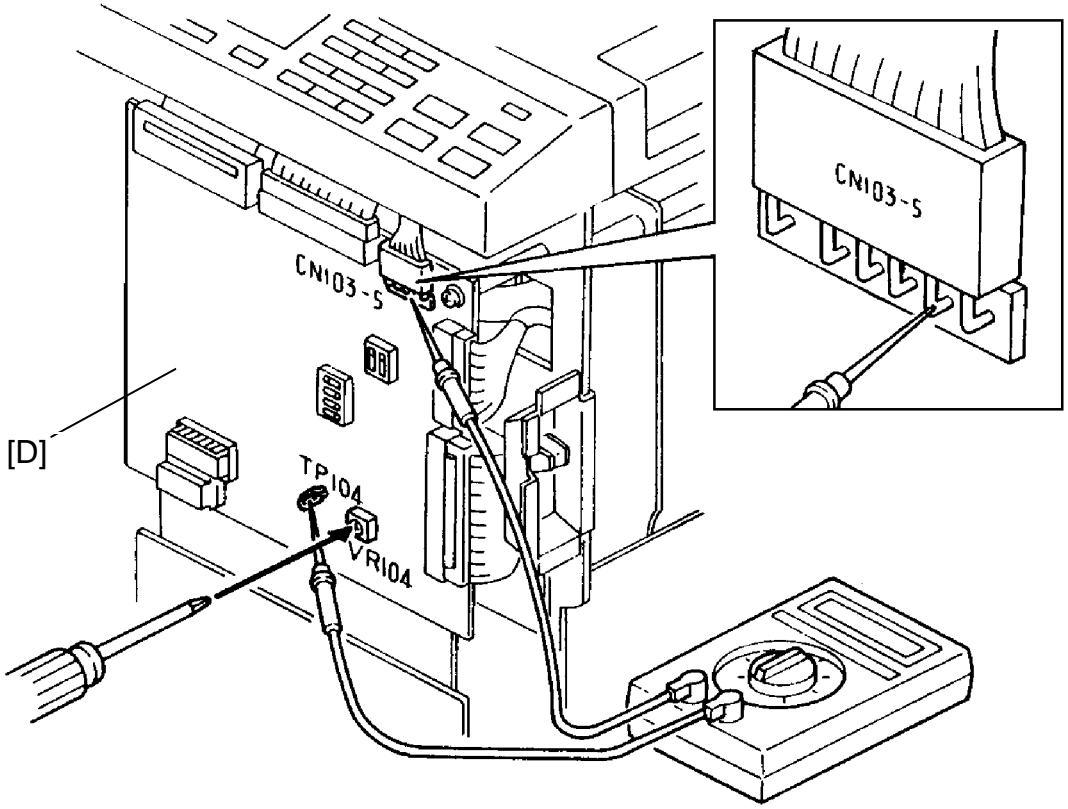



## 6.5 MASTER EJECT UNIT REPLACEMENT

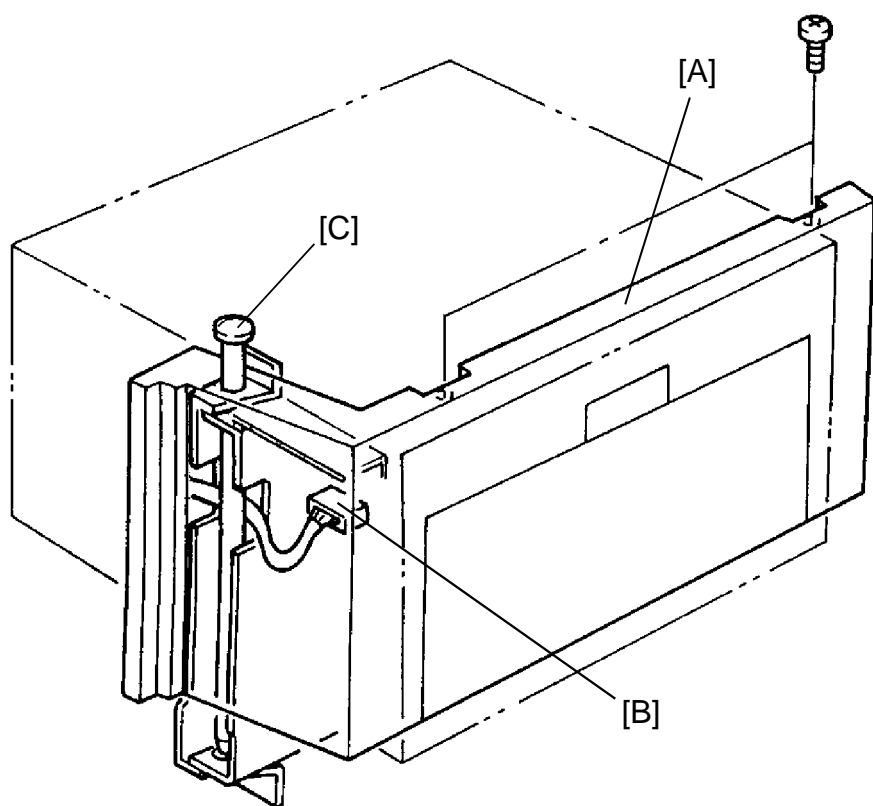

1. Turn off the main switch.
2. Remove the master eject unit cover [A] (2 screws).
3. Disconnect the connector [B].
4. Pull out the shaft [C].
5. Carefully remove the master eject unit.

## 6.6 MASTER EJECT BELT/ROLLER REPLACEMENT

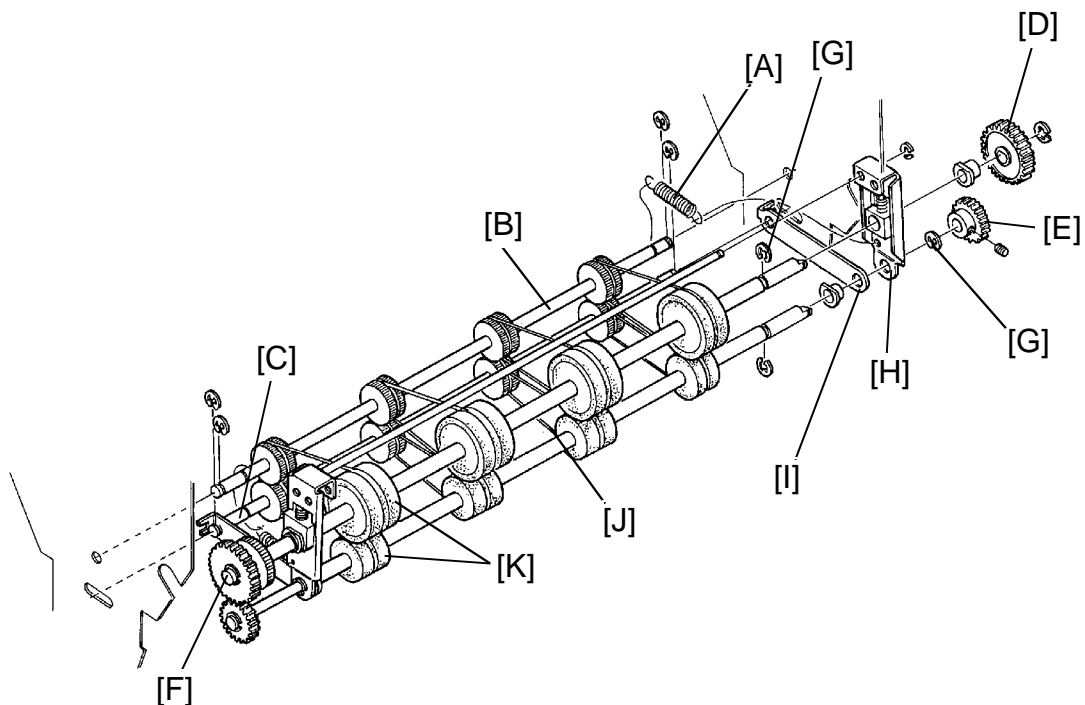

1. Remove the master eject unit. (See page 5-36.)
2. Remove the 2 springs [A] on both sides.
3. Remove the upper shaft [B] (2 E-rings).
4. Remove the lower shaft [C] (2 E-rings).
5. Remove the gear [D] (1 E-ring).
6. Remove the gear [E] (1 Allen Screw).
7. Remove the gear [F] (1 E-ring).
8. Remove the E-rings [G] to pull out both upper (30φ) and lower rollers (20φ) as a set.
9. Remove the Angle [H].
10. Remove the Plate [I].
11. Remove the Belts [J].
12. Remove the Rubber Rollers (30φ, 20φ) [K].

## 7. PAPER FEED SECTION

### 7.1 PAPER TABLE SAFETY SWITCH ADJUSTMENT

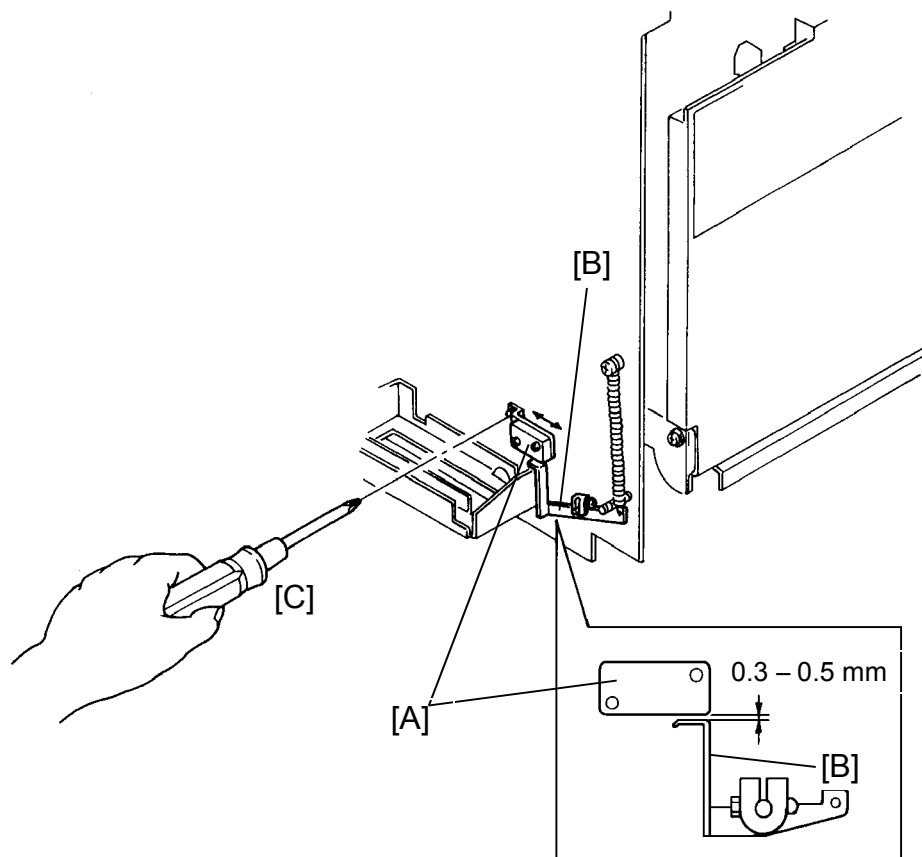

Purpose: To ensure that the paper table safety switch turns on to prevent the paper table from going up when the paper table is closed.

1. Make sure that the safety switch [A] turns off when the paper table is opened and that the safety switch turns on when the paper table is closed. Also, make sure that the distance between the actuator [B] and the safety switch [A] is 0.3 mm to 0.5 mm when the switch turns on.
2. If incorrect, loosen the screw [C] and adjust the switch bracket position.
3. After adjustment, repeat step 1 again.
4. Also, make sure that the safety switch does not turn on when 1,000 sheets of standard weight paper are placed on the paper table.

## 7.2 PAPER TABLE HEIGHT ADJUSTMENT

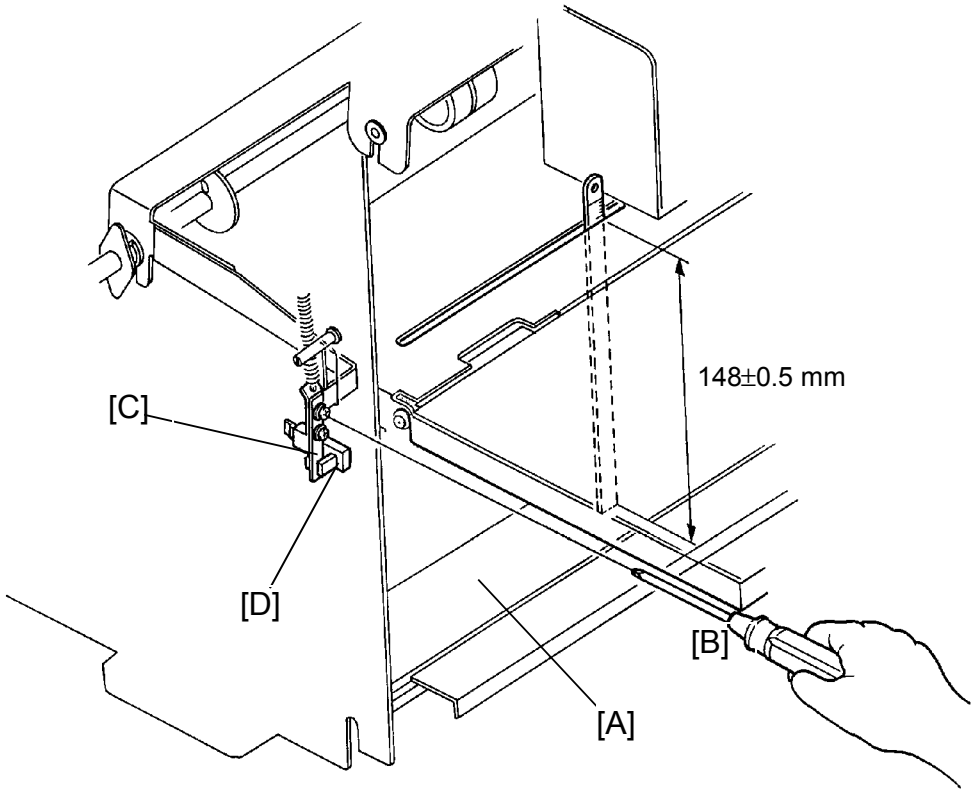

Purpose: To ensure smooth paper feed.

1. Set the paper feed pressure adjusting lever to the upper position.
2. Remove the front cover of the machine.
3. Access I/O check mode (See page 4-11).
  - Enter "0" in the memory display and "4" in the copy counter.
4. Press the Print Start key to raise the paper table.
5. After the paper table stops, insert a scale into the slot at the end of the paper table. Make sure that the distance between the lower stay [A] and the upper face of the table is 147.5 to 148.5 mm.
6. If not, loosen the screw [B] and adjust the position of the actuator [C].
7. After adjustment, repeat step 5 again by lowering and raising the paper table several times.

NOTE: When mounting the actuator, make sure that the actuator does not contact the paper table height sensor [D].

## 7.3 PAPER FEED ROLLER PRESSURE ADJUSTMENT

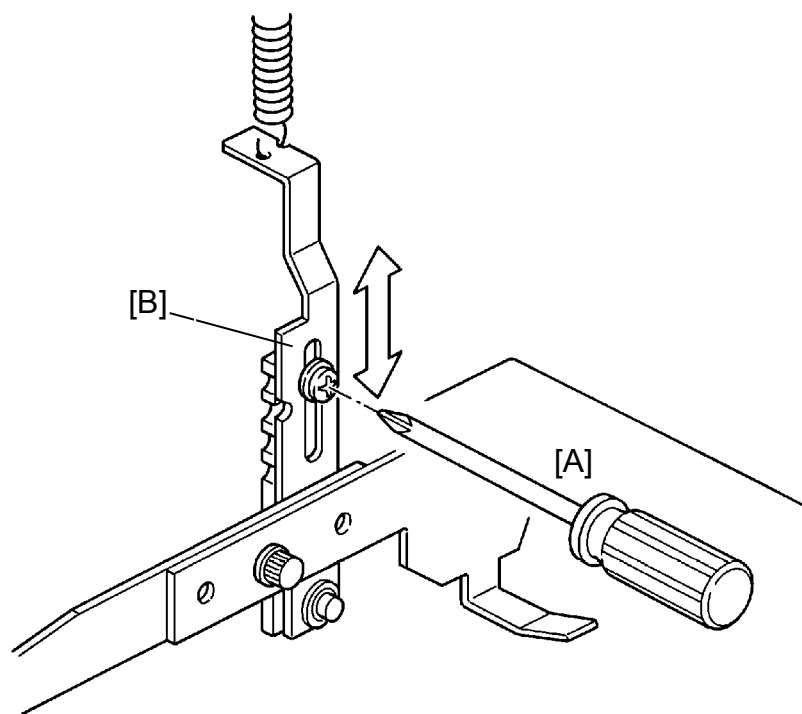

Purpose: To ensure that the paper feed roller exerts sufficient pressure for smooth printing paper feed (weight range 50 g/m<sup>2</sup> to 215 g/m<sup>2</sup>).

### <Step 1>

1. Loosen the screw [A] securing the lower adjusting plate [B].

NOTE: When loosening the screw, hold the lower adjusting plate in the original position for fine adjustment.

2. Adjust the paper feed roller pressure by moving the lower adjusting plate [B] up/down.
  - Up : Increase the pressure
  - Down : Reduce the pressure

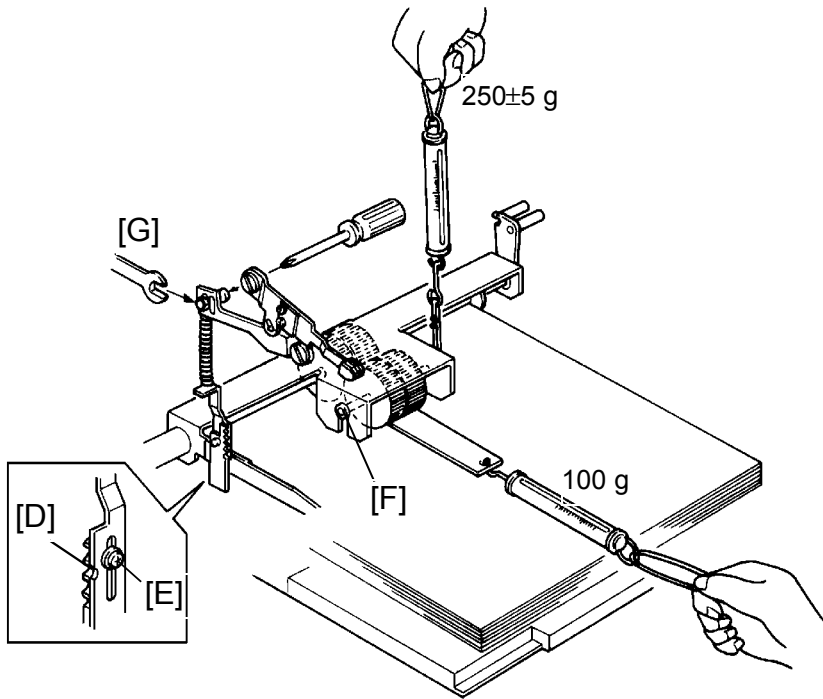

### <Step 2>

This procedure should only be used when the proper pressure cannot be achieved in step 1.

1. Stack about 100 sheets of 65 g/m<sup>2</sup> paper on the paper table. Lift up the paper table until it stops automatically.
2. Set the paper feed roller pressure adjusting lever to the upper position.
3. Remove the front cover, the main board, the image processing board.
4. Remove the master feed unit.
5. Align the lower adjusting plate notch with the center notch of the link [D] and tighten the screw [E].
6. Hook a tension gauge (500-gram range) to the paper feed roller shaft [F] and insert a test sheet between the paper feed roller and the sheets of paper. Then hook a tension gauge (100-gram range) to the test sheet and apply a 100-gram load. In the above condition, gradually pull up the tension gauge hooked to the shaft and make sure that the test sheet can be pulled out when the tension gauge shows 250 ± 5 grams.
7. If not, adjust the pressure by moving the mounting position of the shaft [G].

## 7.4 SEPARATION PLATE PRESSURE ADJUSTMENT: VT2300/VT2500

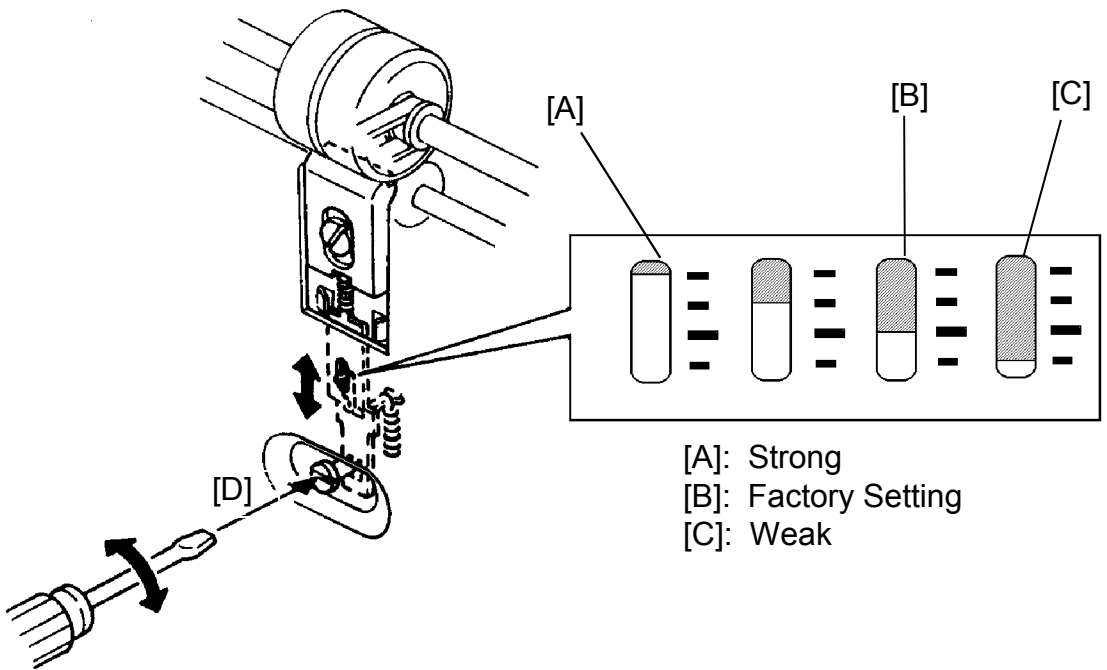

Purpose : To adjust the separation plate pressure for the type of paper being used by the customer

1. Adjust the separation plate pressure by turning the adjusting screw [D].

NOTE: Position the minus groove on the screw head vertically  $\ominus$  or horizontally  $\omin�$ . Otherwise, vibration may cause the screw to turn.

2. After adjustment, make copies to confirm that the paper feeds smoothly without jamming, folding, or wrinkling Use all the types of paper that the customer uses.

## 7.5 LOWER GUIDE PLATE ADJUSTMENT

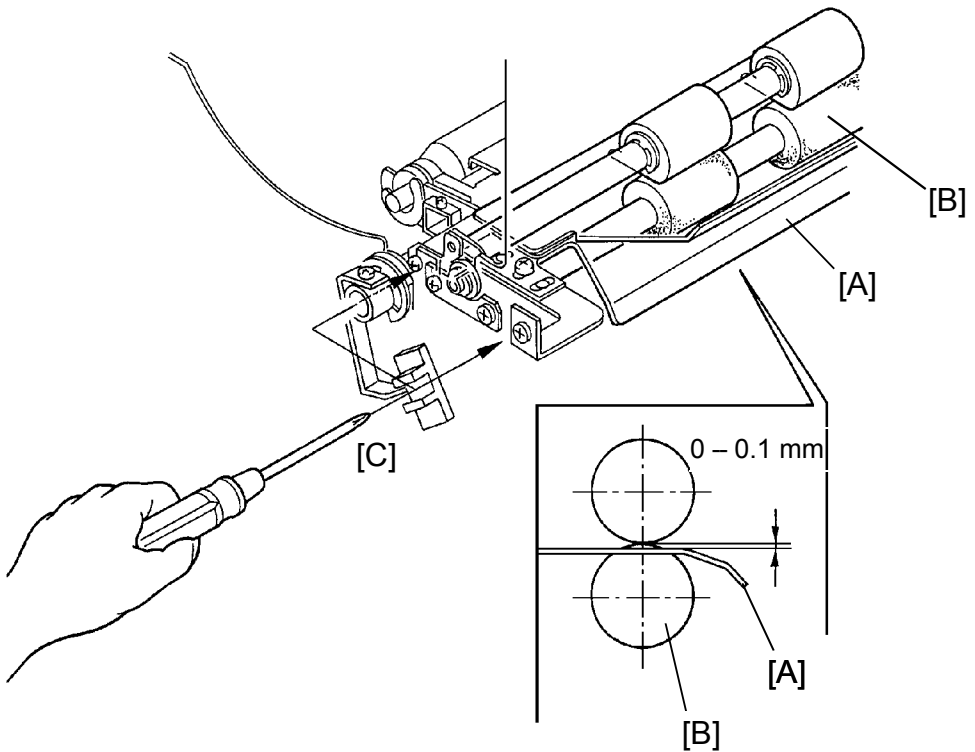

**Purpose:** To ensure a smooth paper feed excluding paper jams, folds, or wrinkles.

1. Make sure that the distance between the lower guide plate [A] and the lower second feed roller [B] is 0 to 0.1 mm as shown.
2. If incorrect, remove both front and rear covers and loosen the screws [C] on both sides. Then, adjust the distance by lowering and raising the lower guide plate.
3. After adjustment, retighten the screws [C].



## 7.6 UPPER SECOND FEED ROLLER ADJUSTING

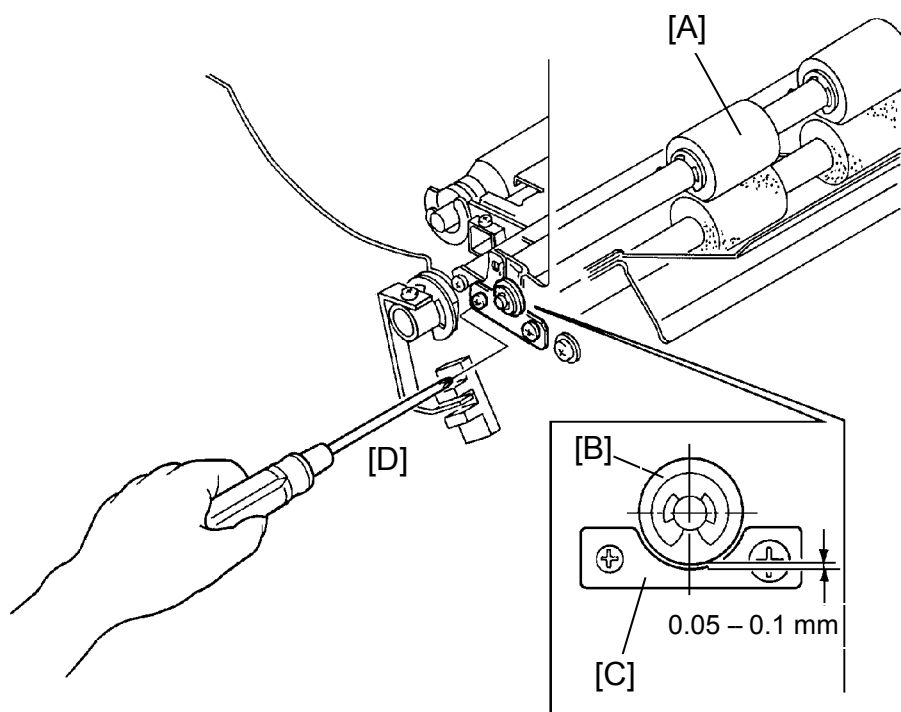

**Purpose:** To ensure that paper is fed between the drum and the pressure roller without skewing.

1. Remove both front and rear covers.
2. Move the second feed roller sector gear fully clockwise, so that the upper second feed roller [A] contacts the lower second feed roller.
3. Make sure that the clearance between the bushing [B] and the bushing supporter [C] is 0.05 to 0.1 mm as shown.
4. If incorrect, loosen the screw [D] and adjust the clearance by moving the bushing supporter.
5. After adjustment, make sure that the feed length of the second feed roller is correct. (The feed length varies with the position of the bushing supporter.)

## 7.7 PAPER FEED ROLLER FEED-LENGTH ADJUSTMENT

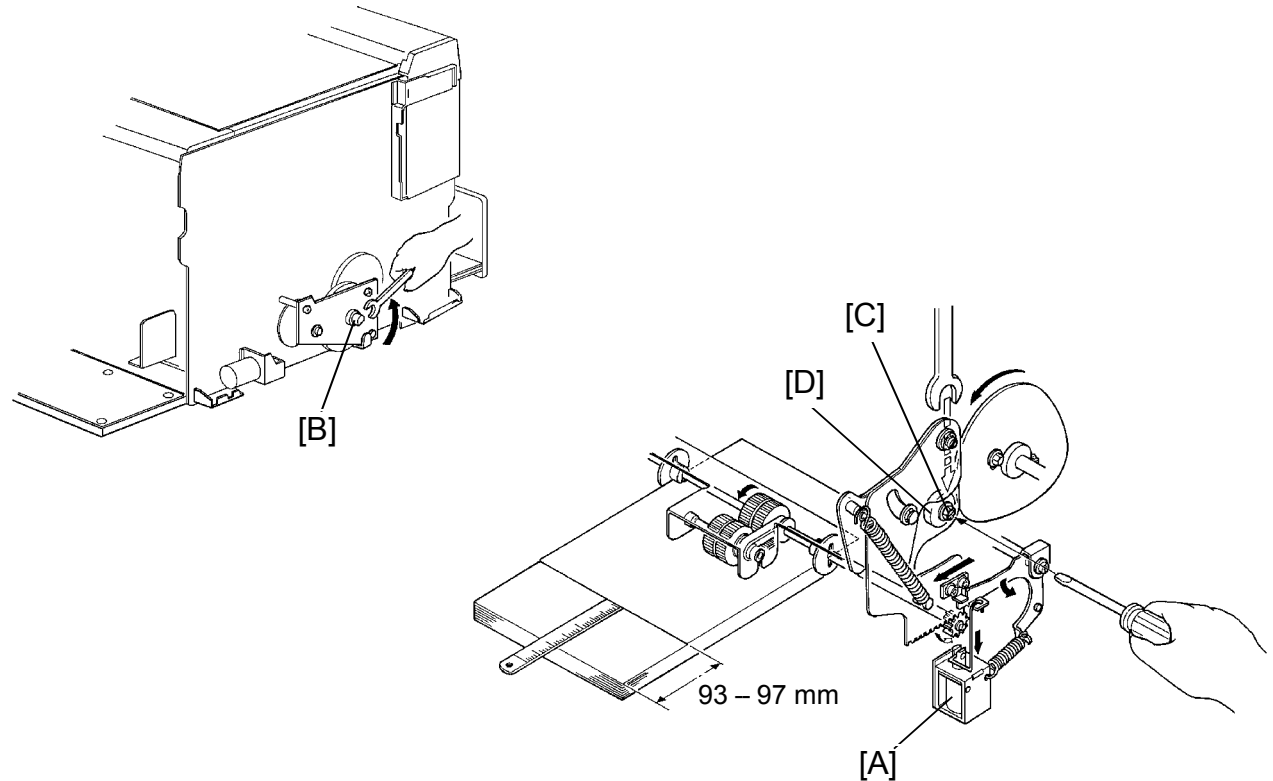

Purpose: To ensure paper feed to the second paper feed roller.

1. Stack about 100 sheets of 65 g/m<sup>2</sup> paper on the paper table.
2. Set the paper feed roller pressure adjusting lever in the upper position.
3. Remove both front and rear covers.
4. Access I/O check mode (See page 4-11).
  - Enter "0" in the memory display and "4" in the copy counter.
5. Press the Print Start key to raise the paper table to the correct position.
6. Turn on the paper feed solenoid [A] manually. Then, turn the rollers counterclockwise by rotating the shaft [B] with a spanner (10 mm).
7. Measure the length of paper fed from the time the paper feed roller starts rotating until it stops rotating. This feed-length should be 93 to 97 mm.
8. If the feed-length is incorrect, adjust the feed-length by loosening the hexagon nut [C] mounted on the sector gear. Then, shift the bearing [D] up or down.
9. After adjustment, repeat steps 5 and 6 again.

## 7.8 PAPER FEED SECTOR GEAR STOPPER CLEARANCE ADJUSTMENT

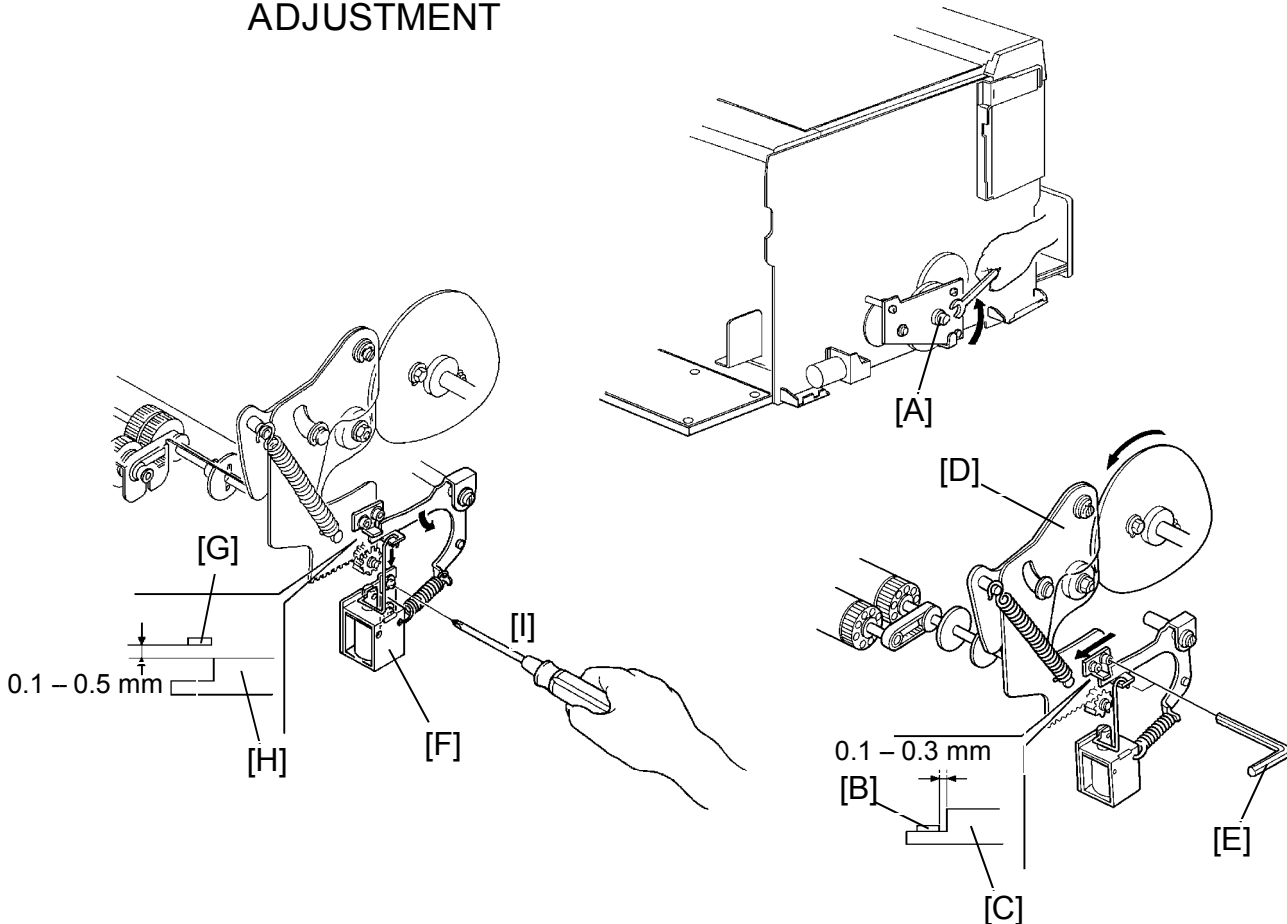

**Purpose:** To ensure that the paper feed roller starts rotating when the paper feed solenoid turns on and stops rotating when the paper feed solenoid turns off.

1. Remove the rear cover.
2. With a spanner (10 mm), gradually turn the shaft [A] counterclockwise.
3. Make sure that the clearance between the sector pin [B] and the sector stopper [C] is 0.1 to 0.3 mm after turning the sector gear [D] fully clockwise.
4. If the clearance is incorrect, loosen the Allen screws [E] and adjust the clearance by shifting the sector pin [B].
5. Manually depress the plunger of the paper feed solenoid [F], and make sure that the clearance between the sector pin [G] and the sector stopper [H] is 0.1 to 0.5 mm.
6. If the clearance is incorrect, loosen the screws [I] and adjust it by shifting the paper feed solenoid bracket up or down.

## 7.9 SECOND FEED ROLLER SECTOR STOPPER CLEARANCE ADJUSTMENT

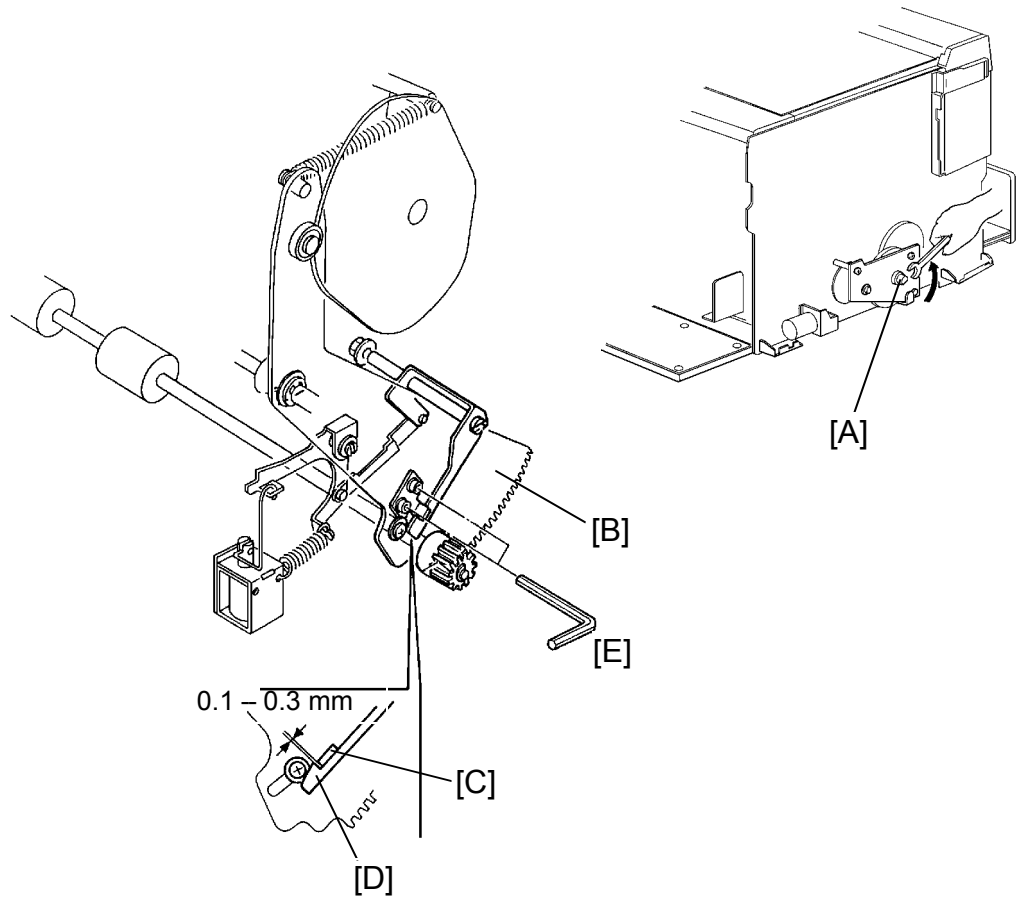

**Purpose:** To ensure that the second feed roller starts rotating when the paper feed solenoid turns on and stops rotating when the paper feed solenoid turns off.

1. Remove the rear cover of the machine.
2. Gradually turn the drum rotating shaft [A] counterclockwise with a spanner (10 mm).
3. After turning the sector gear [B] fully counterclockwise, make sure that the clearance between the sector pin [C] and the sector stopper [D] is 0.1 to 0.3 mm.
4. If the clearance is incorrect, loosen the Allen screws [E] and adjust the clearance between the sector pin and the sector stopper.

## 7.10 SECOND FEED ROLLER FEED LENGTH ADJUSTMENT

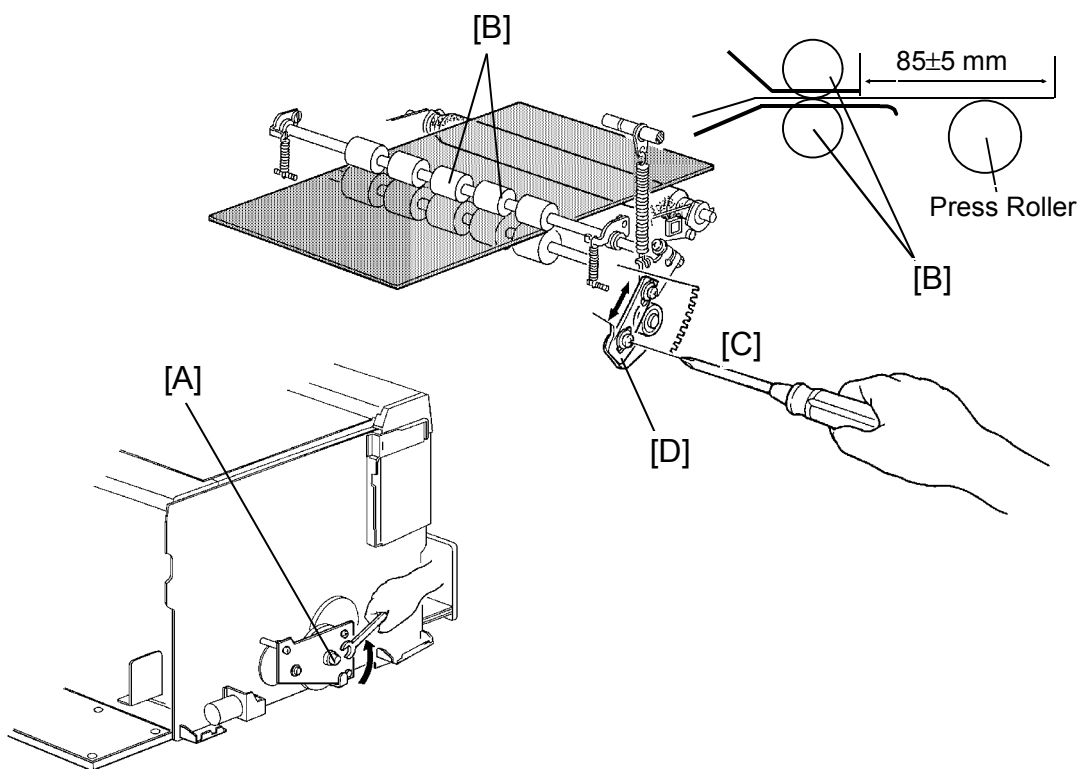

Purpose: To ensure paper feed between the drum and the pressure roller.

1. Remove the drum unit and the rear cover from the machine.
2. Stack about 100 sheets of 65 g/m<sup>2</sup> paper on the paper table.
3. Access I/O check mode (See page 4-11).
  - Enter "0" in the memory display and "4" in the copy counter.
4. Press the Print Start key to raise the paper table to the correct position.
5. Turn on the paper feed solenoid and gradually turn the drum rotation shaft to feed paper by rotating the drum rotation shaft [A] with a spanner (10 mm).
6. Measure the paper feed length from the time the second feed roller [B] starts rotating until it stops rotating. This feed length should be  $85 \pm 5$  mm.
7. If it is not, loosen the screws [C] and adjust the feed length by shifting the second feed roller cam [D] up or down.
8. Check adjustment by repeating steps 5 and 6.
9. After adjustment, retighten the screws [C].

## 7.11 SECOND FEED ROLLER FEED TIMING ADJUSTMENT

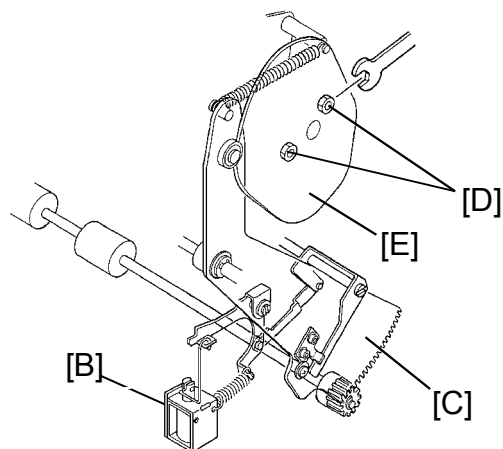
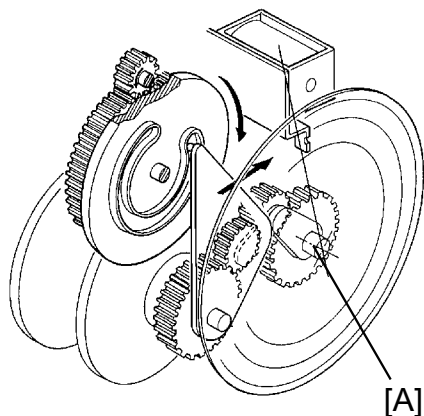

**Purpose:** To ensure paper feed by regulating the start timing of the second feed roller.

1. Stack about 100 sheets of 65 g/m<sup>2</sup> paper on the table.
2. Set the paper feed roller pressure lever in the upper position.
3. Remove both front and rear covers of the machine.
4. Access I/O check mode (See page 4-11).
  - Enter "0" in the memory display and "4" in the copy counter.
5. Press the Print Start key to raise the paper table to the correct position.
6. Set the Image Shifting indicator at "0" position, and turn the drum to the home position for drum replacement.
7. Set a protractor on the image shifting shaft [A].
  - Position the origin of the protractor at the bracket of the master feed clamper solenoid.
8. Turn on the paper feed solenoid [B] and, using a spanner (10 mm), gradually turn the drum rotation shaft to feed the paper.
9. Measure the degrees turned when the second feed roller sector gear [C] starts returning counterclockwise.  
This should be 157°.
10. If incorrect, loosen the 2 hexagon bolts [D] located behind the second feed roller cam [E] and adjust by turning the cam.

## 7.12 PAPER FEED ROLLER REPLACEMENT

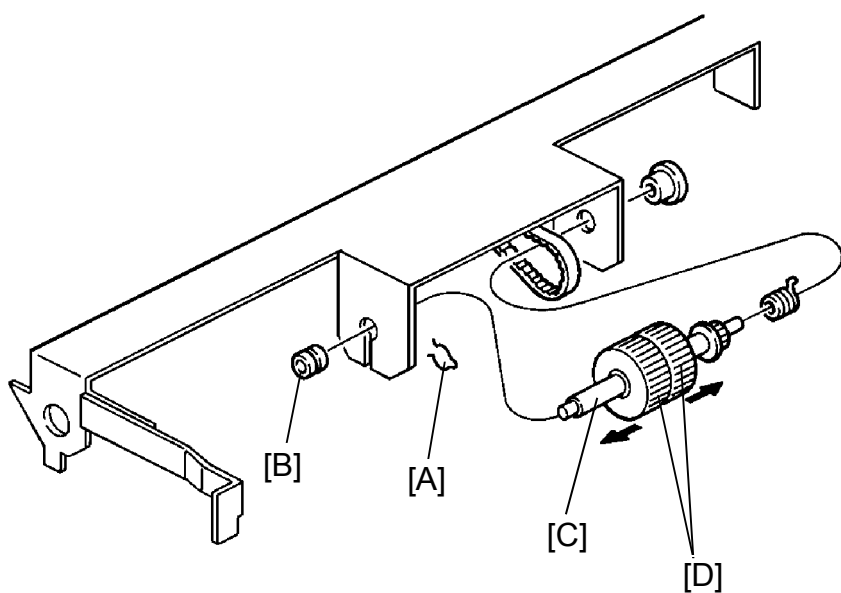

1. Remove the left clamber [A].
2. Remove the left bushing [B].
3. Remove the paper feed roller shaft [C].
4. Remove the 2 paper feed rollers [D].

## 7.13 PAPER FEED ROLLER UNIT REPLACEMENT

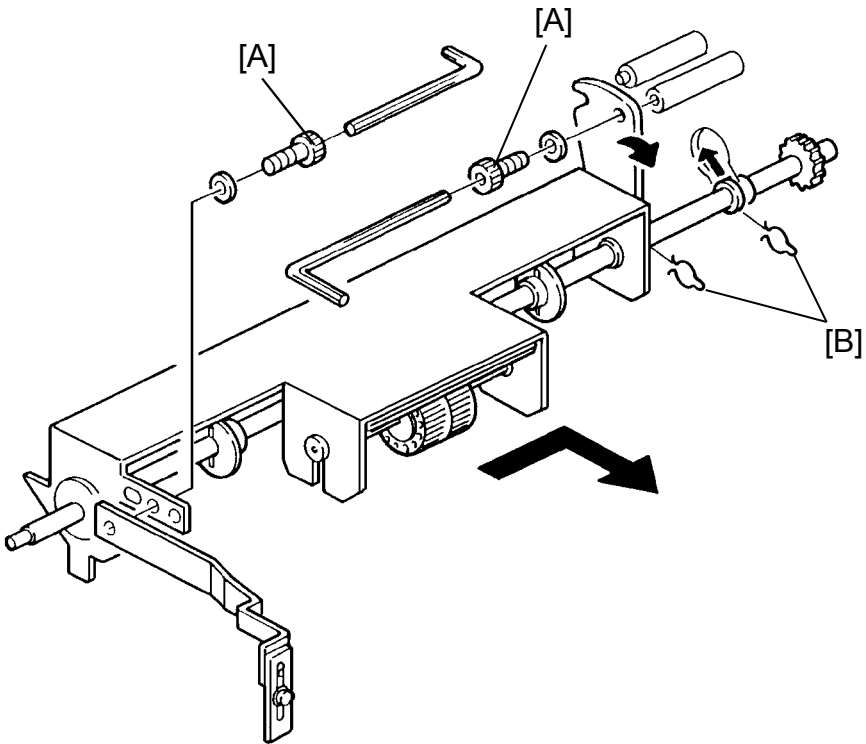

1. Remove 2 hexagon screws [A].
2. Remove the clampers [B].
3. Remove the upper paper feed roller unit from the machine by sliding the shaft to rear.



## 7.14 UPPER SEPARATION ROLLER REPLACEMENT

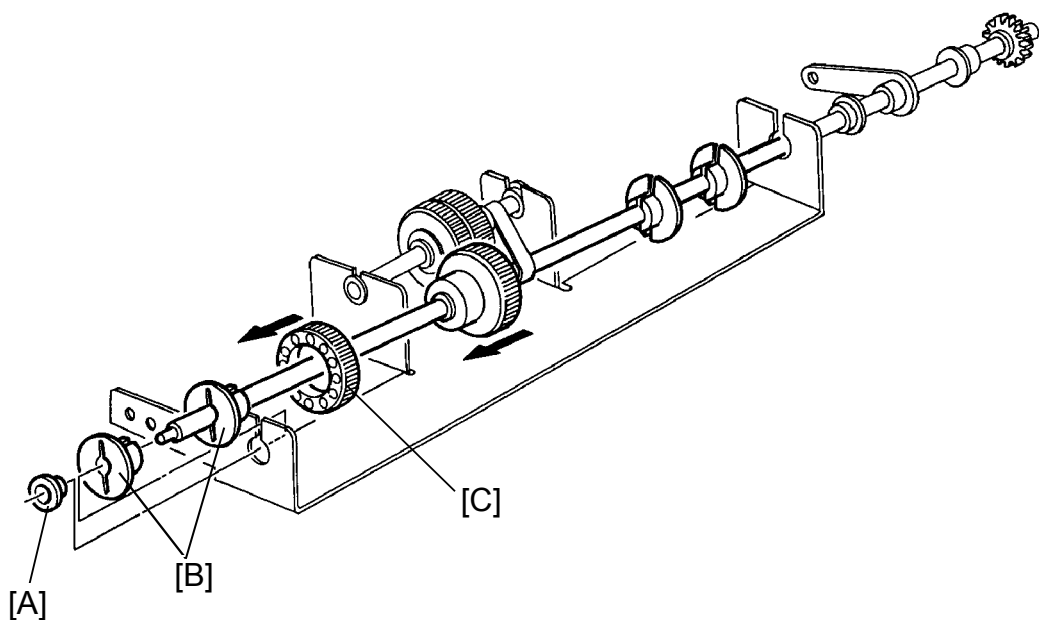

1. Remove the paper feed roller unit from the machine (See page 5-51).
2. Remove the bushing [A].
3. Remove the paper guide disks [B].
4. Remove the upper separation roller [C].

## 7.15 SEPARATION PLATE / LOWER SEPARATION ROLLER REPLACEMENT

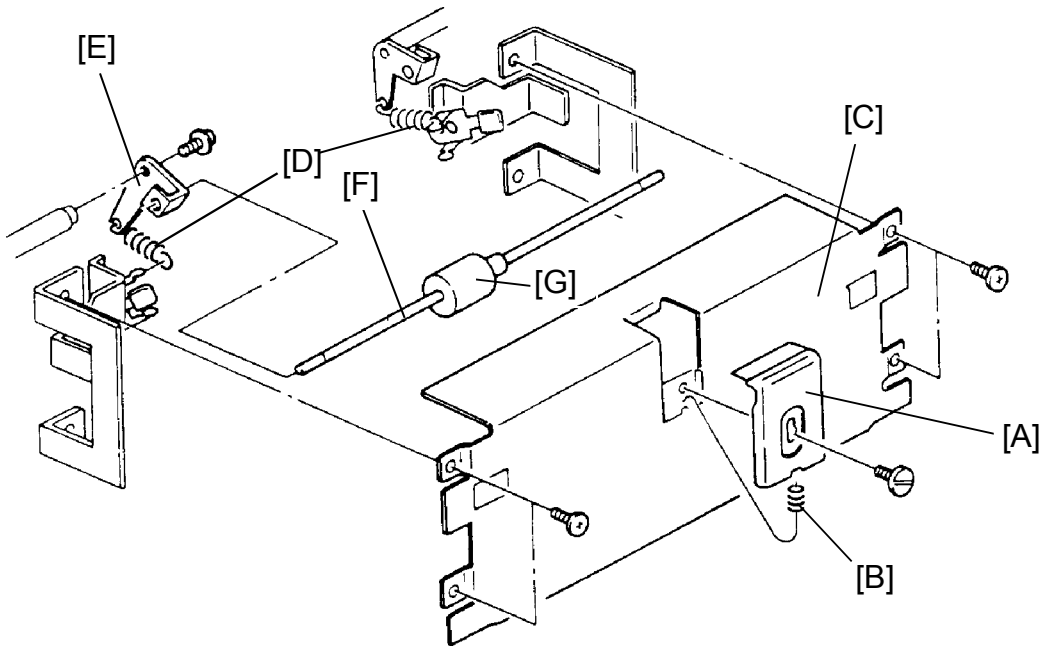

### Separation Plate:

1. Remove the separation plate [A] with the spring [B] located under the separation plate (1 screw).

### Lower Separation Roller:

1. Remove the paper feed roller unit from the machine (See page 5-51).
2. Remove the front plate [C] of the paper feed section (4 screws).  
Lift up then pull out horizontally.
3. Remove the springs [D] on both sides.
4. Remove the separation levers [E] on both sides (1 screw each).
5. Remove the lower separation roller shaft [F].
6. Remove the lower separation roller [G] (Allen screw).

## 8. PRINTING SECTION

### 8.1 PAPER DETECTING ARM CLEARANCE ADJUSTMENT

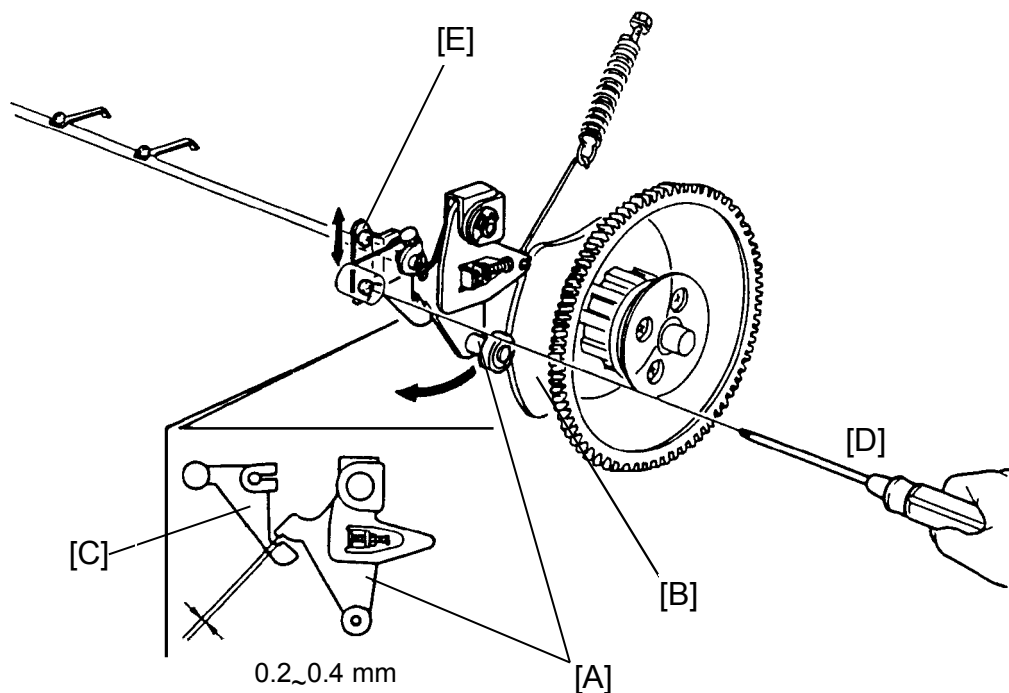

Purpose: To ensure that printing pressure is applied during paper feed, and is released correctly afterwards.

1. Remove the rear cover of the machine.
2. Using a spanner (10 mm), gradually turn the drum rotation shaft counterclockwise to position the bearing of the pressure release arm [A] on the top of the pressure cam [B].
3. Make sure that the clearance between the paper detecting arm [C] and the pressure release arm is 0.2 to 0.4 mm.
4. If incorrect, loosen the screws [D] and adjust the clearance by shifting the paper detecting bracket [E] up or down.
5. After adjustment, confirm the printing pressure ON/OFF mechanism by monitoring a print run.

## 8.2 PRESSURE ROLLER POSITION ADJUSTMENT

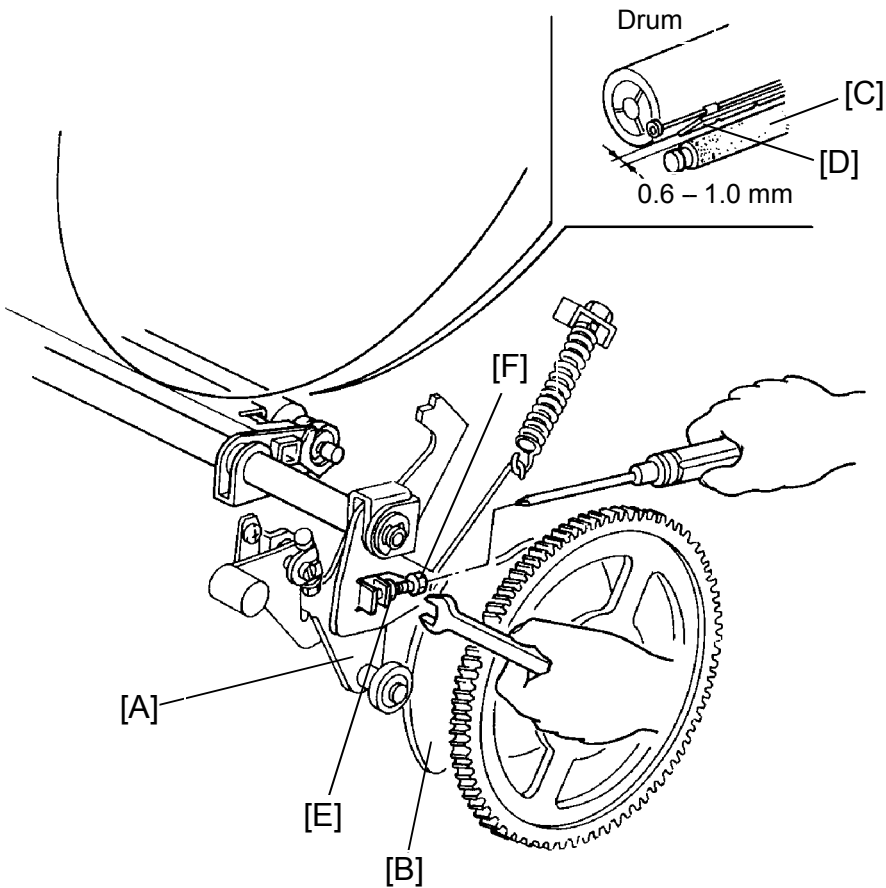

Purpose: To ensure that the pressure roller does not contact the clamber section of the drum.

1. Remove the rear cover of the machine.
2. Using a spanner (10 mm), turn the drum rotation shaft counterclockwise and position the bearing of the pressure release arm [A] on top of the pressure cam [B].
3. While holding this condition, make sure that the distance between the pressure roller [C] and the tip of the clamber [D] is 0.6 to 1.0 mm.
4. If incorrect, loosen the hexagon nut [E] and adjust the clearance by turning the screw [F].

## 8.3 PRESSURE TIMING ADJUSTMENT

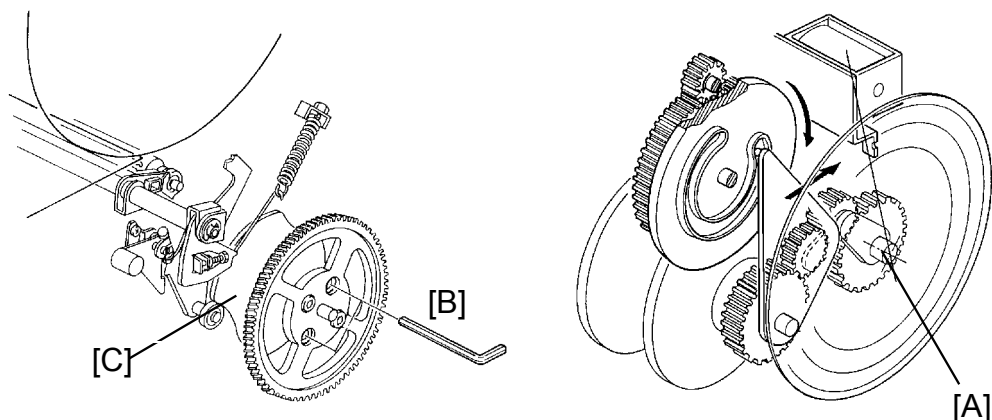

**Purpose:** To ensure that the maximum printing area is within specifications, and that the ink does not stain the trailing edge.

1. Stack about 100 sheets of 65 g/m<sup>2</sup> paper on the table.
2. Set the paper feed roller pressure lever to the upper position.
3. Remove both front and rear covers of the machine.
4. Access I/O check mode (See page 4-11).
  - Enter "0" in the memory display and "4" in the copy counter.
5. Press the Print Start key to raise the paper table to the correct position.
6. Set the Image Shifting indicator at "0" position, and turn the drum to the home position for drum replacement.
7. Set a protractor on the image shifting shaft [A].
  - Position the origin of the protractor at the bracket of the master feed clamper solenoid.
8. Using a spanner (10 mm), turn the drum rotation shaft counterclockwise while pressing in the plunger of the paper feed solenoid and the printing pressure solenoid.
9. Turn the drum rotation shaft a little further, and stop it when the pressure roller begins to contact the drum surface.
10. In the above condition, measure the degrees turned, this should be 225±1 degrees.
11. If incorrect, loosen the screws [B] of the pressure cam [C] and adjust by turning the pressure cam.

## 8.4 PRINTING PRESSURE ADJUSTMENT

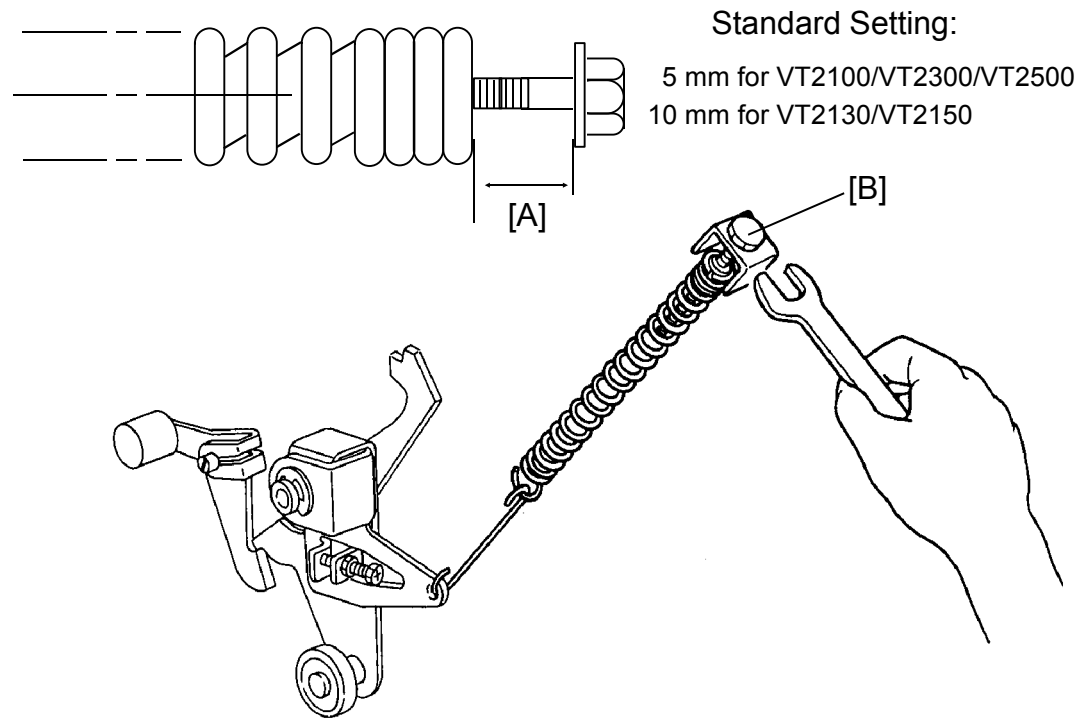

Purpose: To make better print results without decreasing the run length.

1. Remove the rear cover of the machine.
2. Adjust the clearance [A] to be 5 mm for VT2100/VT2300/VT2500 (10 mm for VT2130/VT2150) by turning the adjusting bolt [B].

## 8.5 PRINTING PRESSURE STOPPER CLEARANCE ADJUSTMENT

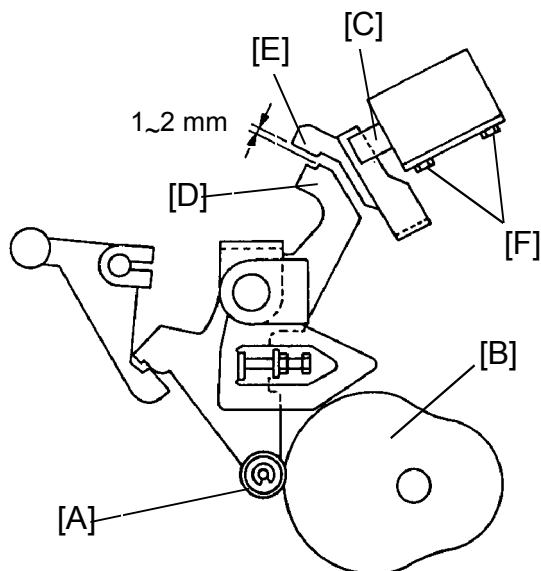

**Purpose:** To ensure that printing pressure stopper is released when paper feed start, and is locked within one drum rotation when a paper jam occurs.

**NOTE:** Perform this adjustment after adjusting the clearance of the paper detecting arm.

1. Using a spanner (10 mm), gradually turn the drum rotation shaft counter-clockwise to position the bearing [A] of the pressure release arm on the top of the pressure cam [B].
2. Manually press in the plunger [C] of the printing pressure solenoid and confirm that the clearance between the printing pressure ON/OFF lever [D] and the printing pressure stopper [E] is 1 to 2 mm.
3. If incorrect, loosen the hexagon head screws [F] and adjust the clearance by moving the printing pressure solenoid.

## 8.6 PRESSURE ROLLER REPLACEMENT

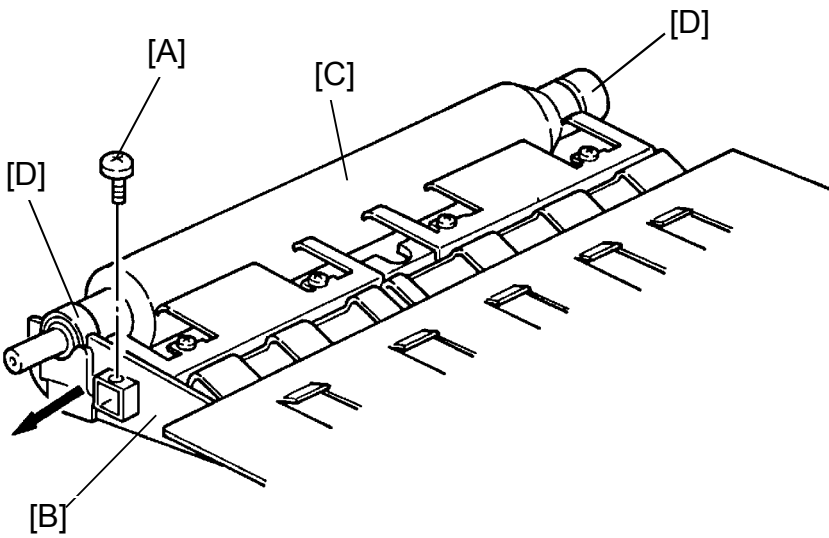

1. Remove a screw [A].
2. Remove the holding plate [B].
3. Remove the pressure roller [C].
4. Remove both right and left bearings [D] (2 E-rings).



## 9. DRUM SECTION

### 9.1 MAIN DRIVE BELT TENSION ADJUSTMENT

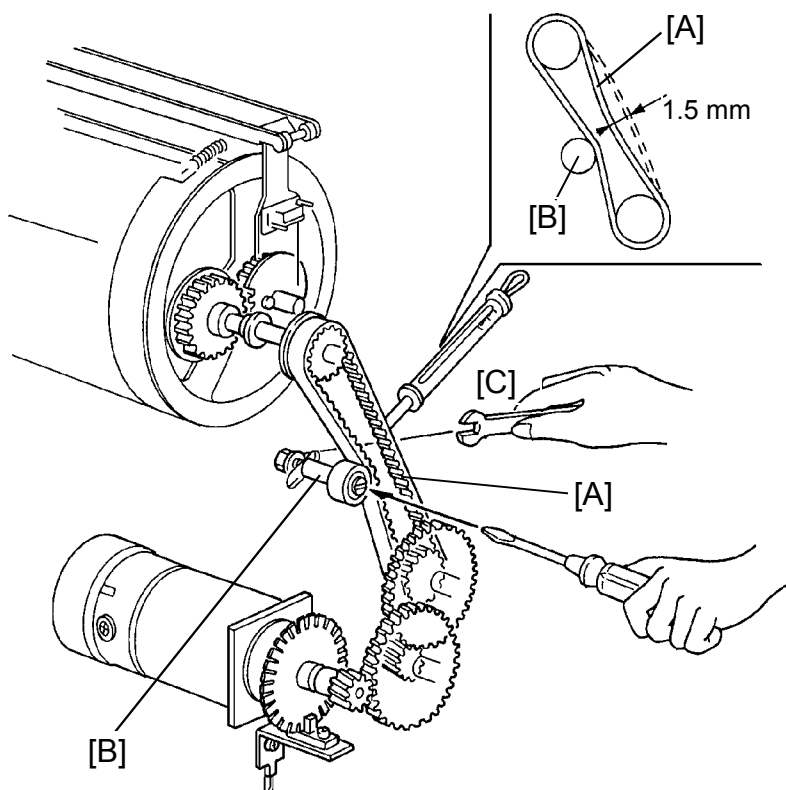

Purpose: To ensure that correct main motor rotation is transmitted to the drum.

1. Remove the rear cover of the machine.
2. Apply a 1000-gram load using a tension gauge to the center of the main drive belt [A]. Make sure that the belt deflects 1.5 mm.
3. If incorrect, remove the drum unit and adjust the belt tension by moving the tensioner shaft [B] after loosening the nut [C].
4. After adjustment, tighten the nut completely.

## 9.2 DRUM ROTATION SENSOR ADJUSTMENT

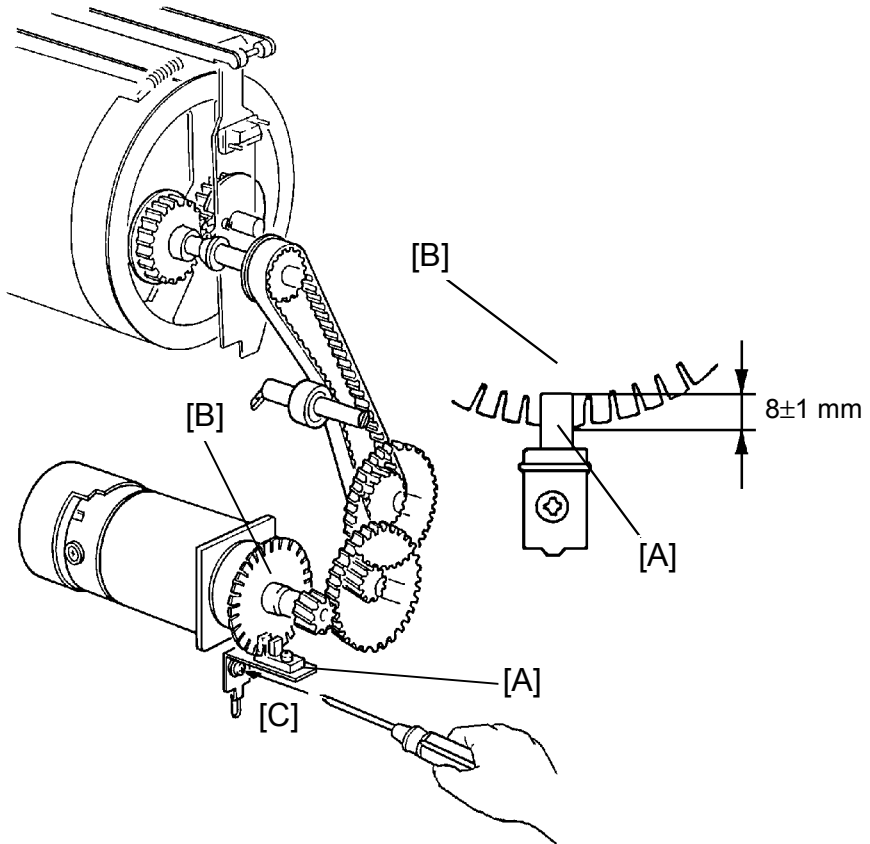

Purpose: To ensure correct main motor speed detection.

1. Remove the rear cover of the machine.
2. Make sure that the drum rotation sensor [A] is positioned so that the pulse disk [B] is inserted into the sensor by  $8 \pm 1$  mm as shown above.
3. If not, loosen the screw [C] securing the sensor bracket and adjust the sensor bracket position.
4. After adjustment, set a spanner (10 mm) into the drum shaft and rotate the drum to make sure that the pulse disk does not contact the sensor during a rotation.

### 9.3 PRINTING SPEED ADJUSTMENT:

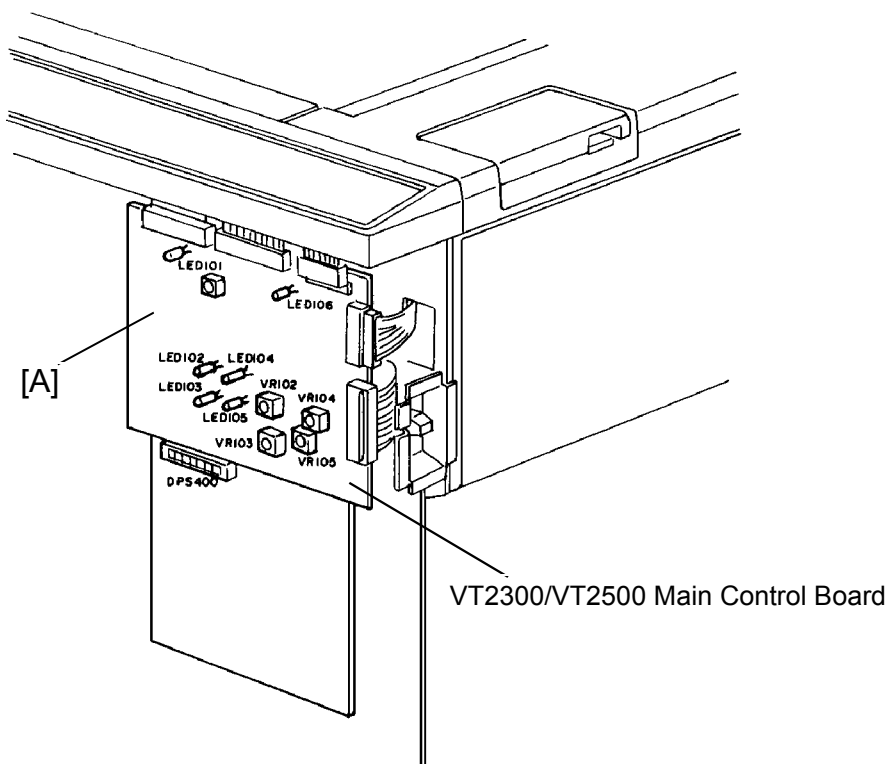

Purpose: To set the maximum speed at  $120 \pm 10$  rotations/minute.

1. Press the Speed Change key to set the speed at the maximum level.
2. Press the reset key while pressing the "0" key and make sure that the drum rotation speed is  $120 \pm 10$  rotations/minute.

VT2100/VT2130/VT2150 Only:

3. If not, remove the front cover of the machine and turn on DIP SW 100-6 on the Main Control PCB [A]. Then adjust the speed by turning VR100.

VT2300/VT2500 Only:

3. If not, remove the front cover of the machine and then adjust the speed by turning VR101 on the Main Control PCB [A].

## 9.4 DRUM STOPPER ADJUSTMENT

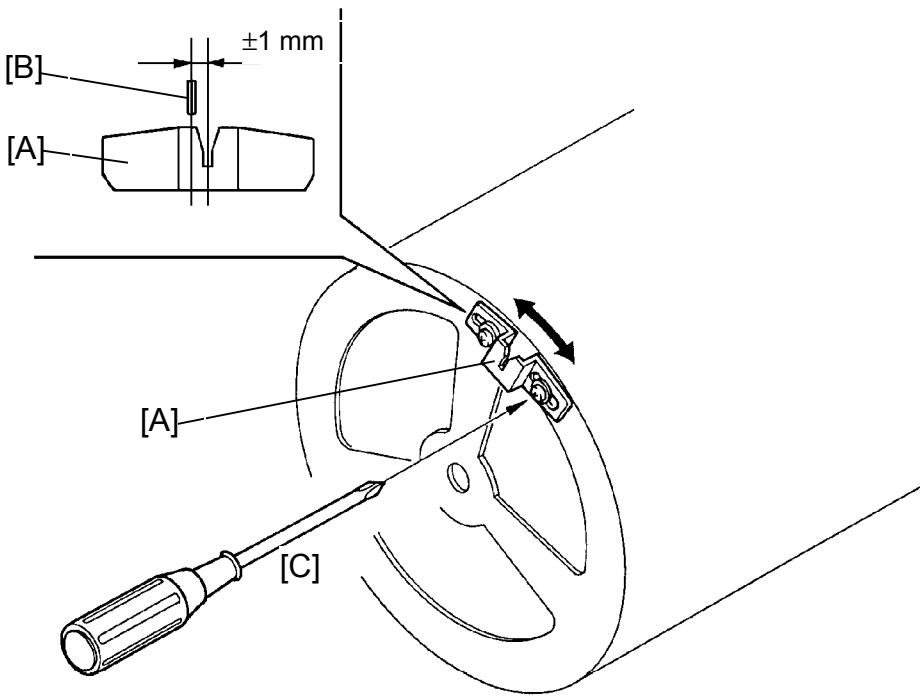

Purpose: To ensure that the drum is securely locked when the drum unit is pulled out.

1. Press the Drum Rotation button to stop the drum at the home position for drum replacement.
2. Make sure that the distance between the center of the drum lock [A] and the center of the drum stopper [B] is less than  $\pm 1$  mm.
3. If incorrect, loosen the screws [C] and adjust by moving the drum lock [A].

## 9.5 MASTER FEED CLAMPER CAM ADJUSTMENT

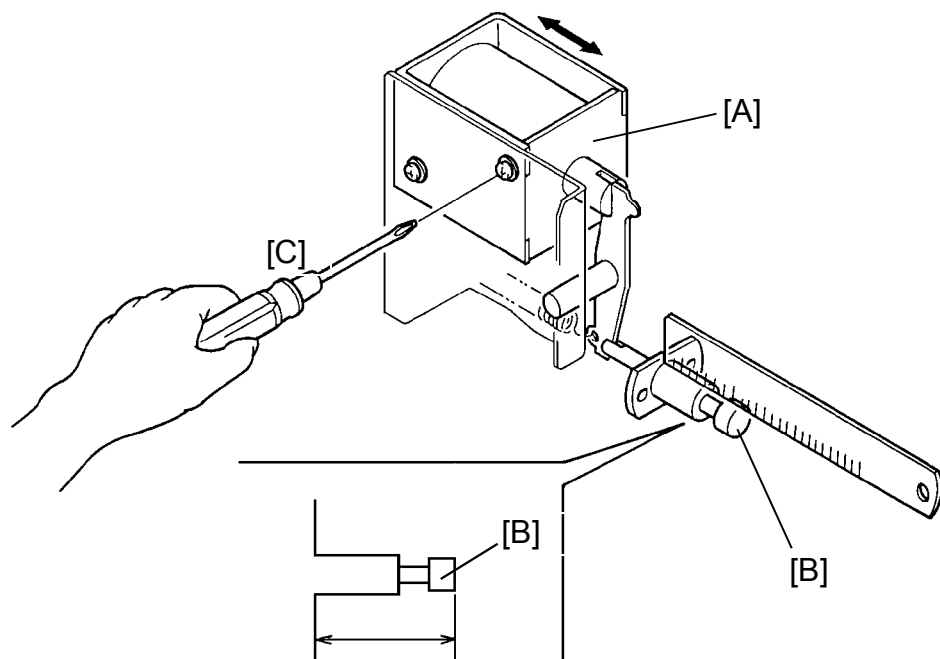

ON=  $29 \pm 0.5$  mm      OFF= less than 25 mm

**Purpose:** To ensure that the master feed clasper is opened during the master feed process and is closed during other processes.

1. Remove the drum unit from the machine and open the master eject unit.
2. Remove the rear cover of the machine
3. Access I/O check mode (See page 4-11).
  - Enter "0" in the memory display and "9" in the copy counter.
4. Press the Print Start key to turn on the master feed clasper solenoid [A].
5. Make sure that the distance between the solenoid and the edge of the opening cam [B] is  $29 \pm 0.5$  mm when the master feed clasper solenoid turns on.
6. If not, loosen the mounting screws [C] and adjust the solenoid position.

**CAUTION:** Do not turn on the solenoid any longer than 10 seconds.

7. After adjustment, retighten the mounting screws.

## 9.6 MASTER EJECT CLAMPER CAM ADJUSTMENT

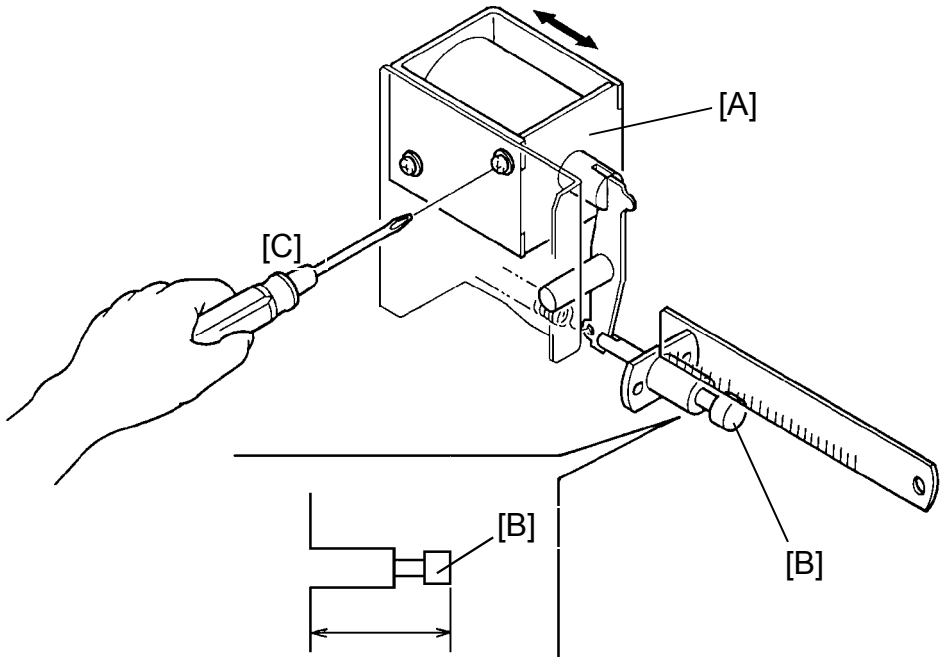

ON=  $29 \pm 0.5$  mm      OFF= less than 25 mm

**Purpose:** To position the master eject clamber cam so that the master clamber opens correctly during the master eject process and closes correctly for all other processes.

1. Remove the drum unit from the machine and open the master eject unit.
2. Remove the rear cover of the machine.
3. Access I/O check mode (See page 4-11).
  - Enter "0" in the memory display and "8" in the copy counter.
4. Press the Print Start key to turn on the master eject clamber solenoid [A].
5. Make sure that the distance between the bushing and the edge of the opening cam [B] is  $29 \pm 0.5$  mm when the master eject clamber solenoid turns on.
6. If not, loosen the mounting screws [C] and adjust the position of the master eject clamber solenoid.

**CAUTION:** Do not turn on the solenoid any longer than 10 seconds.

5. After adjustment, retighten the mounting screws.

## 9.7 INK DETECTING PIN POSITION ADJUSTMENT

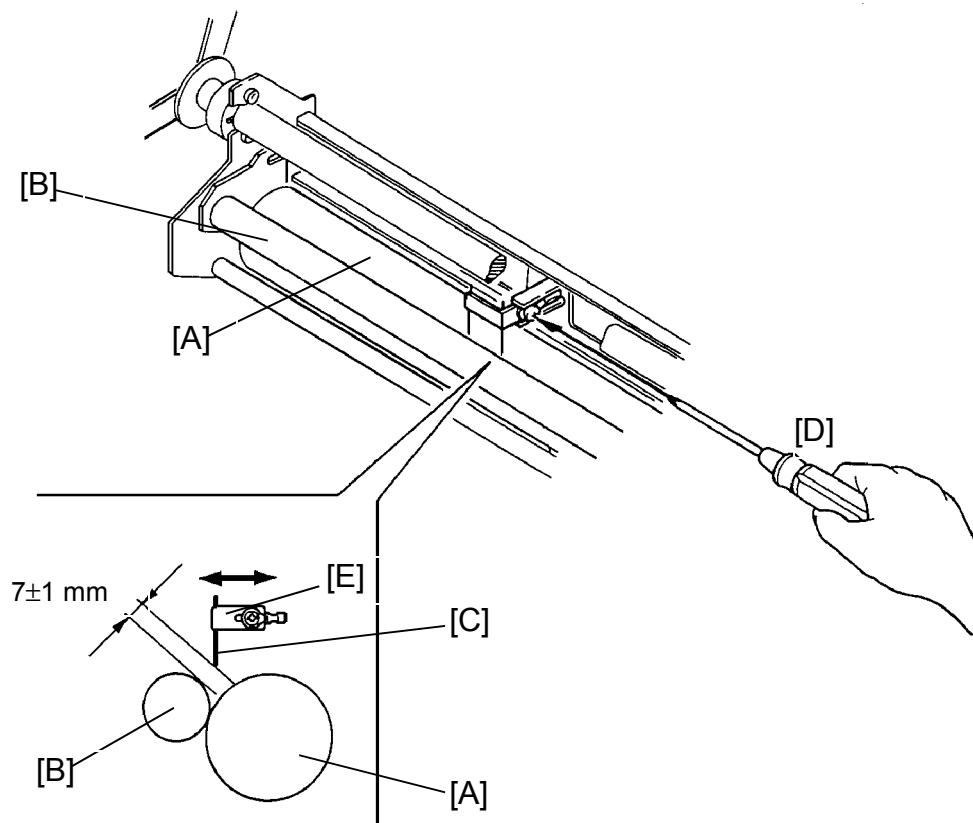

Purpose: To ensure detection of ink built-up between the ink roller and the doctor roller.

1. Remove the drum unit.
2. Remove the master clasper.
3. Remove the tetron screen and the metal screens from the drum unit.
4. Remove the ink around the ink roller [A] and the doctor roller [B].
5. Make sure that the distance between the end of detecting pin [C] and the doctor roller surface is  $7 \pm 1$  mm.
6. If incorrect, loosen the screw [D] and adjust the distance by moving the ink detecting pin bracket [E].
7. After adjustment, retighten the screw [D].

## 9.8 DOCTOR ROLLER CLEARANCE ADJUSTMENT

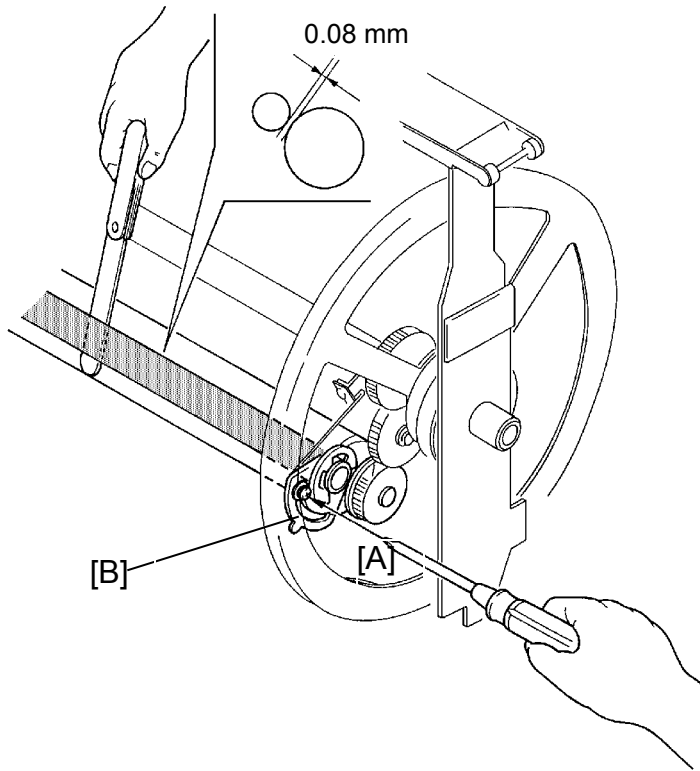

**Purpose:** To equalize the ink thickness around the ink roller and prevent uneven image.

1. Remove the drum unit.
2. Remove the master clamper.
3. Remove tetron screen and the metal screens from the drum unit.
4. Wipe off the ink around the ink roller and the doctor roller.
5. Insert a 0.08-mm gap gauge between the doctor roller and the ink roller. Then make sure that a 0.1-mm gauge can not penetrate the gap.

**NOTE:** Check the gap at the right, center, and left positions.

6. If the gap is not within specifications, loosen the screws [A] on both sides and adjust the gap by turning the eccentric bushings [B] on both sides.

**NOTE:** Before adjustment, remove the drive gear located on the operation side of the doctor roller as the drive gear restricts the adjustment.



## 9.9 INK ROLLER UNIT POSITION ADJUSTMENT

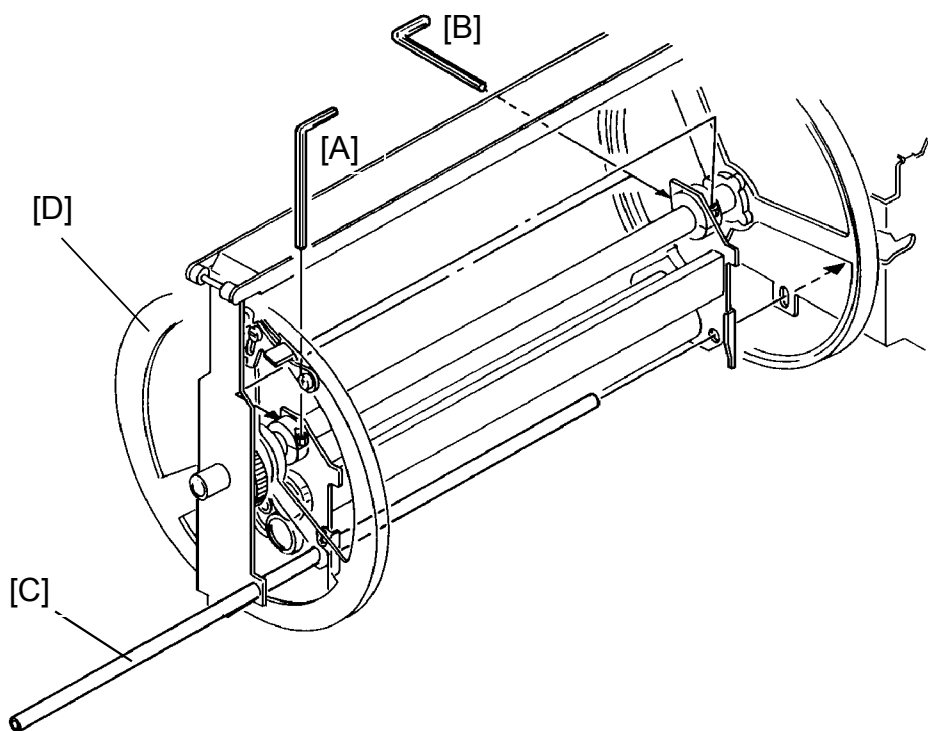

**Purpose:** To ensure that the pressure of the pressure roller is applied evenly to the ink roller (the difference in distance from the center to either end should be less  $\pm 0.5$  mm).

1. Remove the drum unit from the machine.
2. Remove the tetron and the metal screens from the drum unit.
3. Loosen the bolts [A] and the screws [B] that secure the ink roller unit to the drum shaft.
4. Insert the drum gauge [C] in the holes in both side plates of the drum unit and the ink roller unit.

**NOTE:** The part number of the drum gauge is C2009001.

5. In the above condition, tighten the bolts [A] and the screws [B] so that the thrust play of the flange [D] is 0.05 to 0.2 mm.

## 9.10 INK SUPPLY SOLENOID POSITION ADJUSTMENT

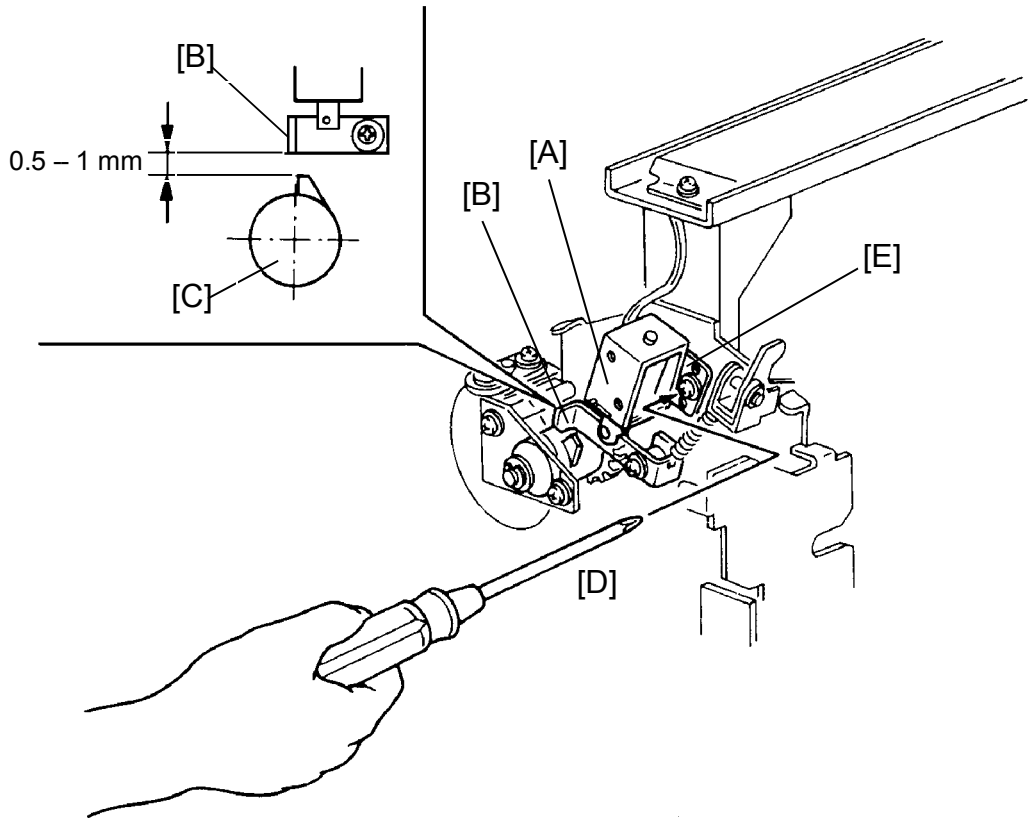

Purpose: To ensure that the clutch sleeve is released by the stopper when the ink supply solenoid [A] turns on.

1. Remove the drum unit from the machine.
2. Remove the front cover of the drum unit.
3. Press in the solenoid plunger by hand and make sure that the distance between the stopper [B] and the clutch sleeve [C] is 0.5 mm to 1.0 mm as shown.
4. If incorrect, loosen the screw [D] and adjust the distance by moving the solenoid bracket [E].
5. After adjustment, retighten the screw [D].

## 9.11 DRUM LOCK SOLENOID ADJUSTMENT: VT2300/VT2500

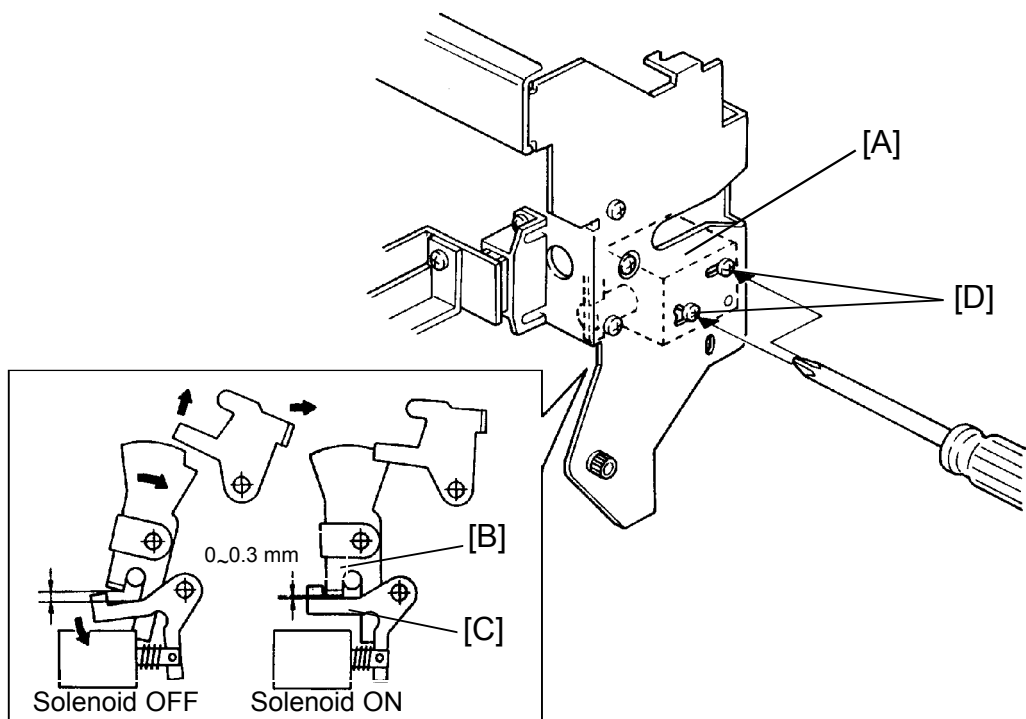

Purpose : To prevent the drum unit from being removed when it is not at the original drum position.

1. Install the drum unit in the machine.
2. Access I/O check mode (See page 4-11).
  - Enter "0" in the memory display and "34" in the copy counter.
3. Press the Print Start key to turn on the drum lock solenoid [A].
4. Make sure that the drum lock arm [B] and the stopper [C] are no further than 0.3 mm apart when the solenoid turns on.
5. If the drum and the stopper are too far apart, loosen the 2 screws [D] and adjust the drum lock solenoid position.

## 9.12 MASTER DETECTING SENSOR ADJUSTMENT: VT2300/VT2500

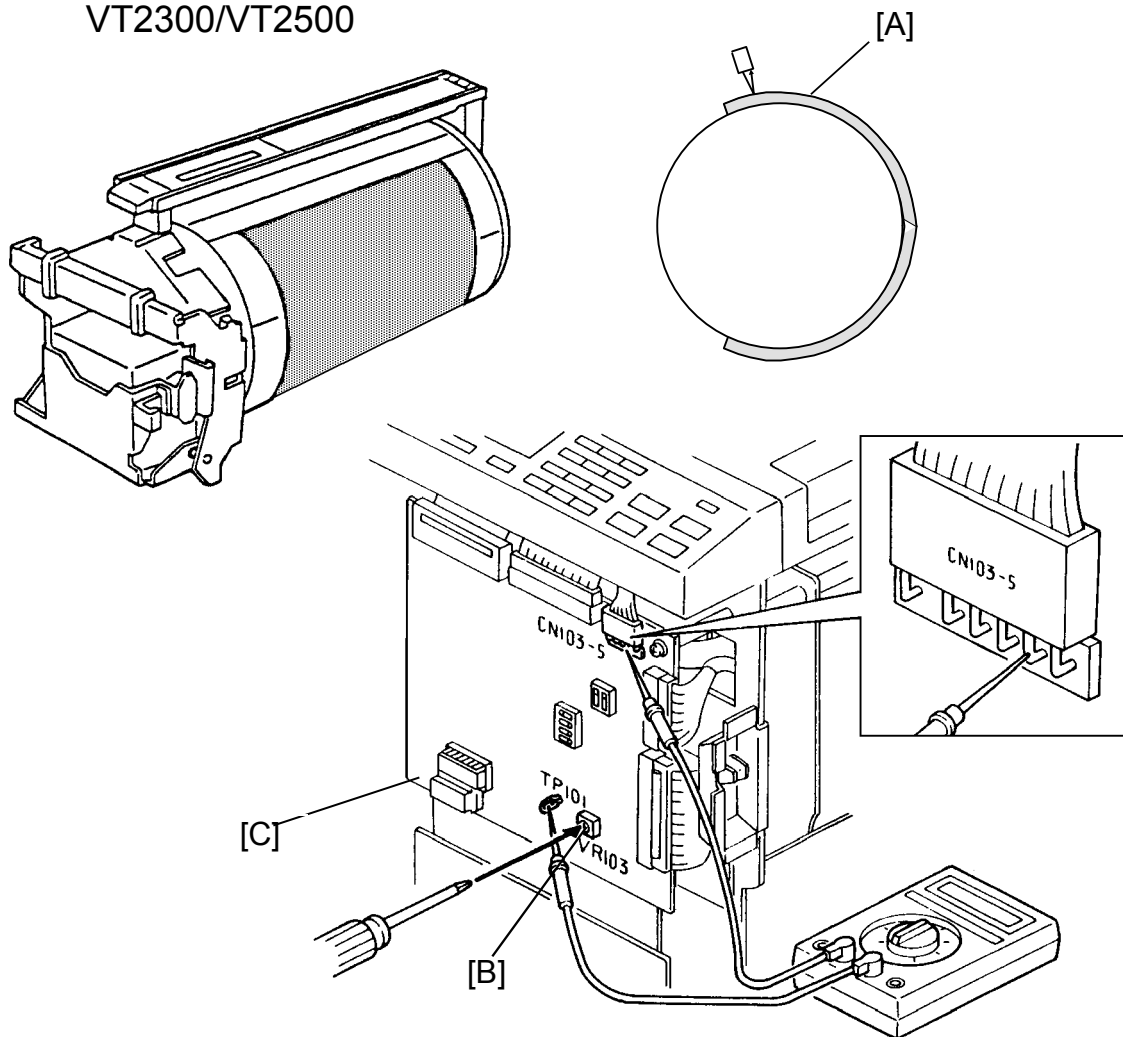

1. Remove the front cover.
2. Remove the master [A] from the drum. Then, confirm that the voltage between TP101 and GND (CN103-5) is  $0.9 \pm 0.1V$  when no master is on the drum.
3. If the voltage is outside the specified range, adjust VR103 [B] on the main control board [C].
4. Place a master on the drum.

NOTE: Make sure the master leading edge is clamped to the drum clamber and that the master [A] is wrapped correctly on the drum.

5. Make sure that the voltage between TP101 and GND (CN103-5) on the main control board is 3.0V or higher.

## 9.13 INK DETECTION ADJUSTMENT

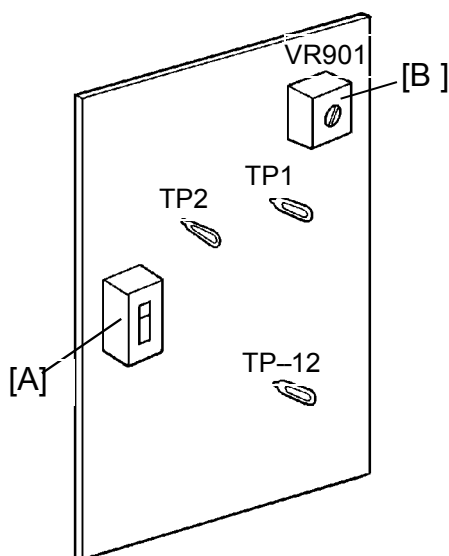
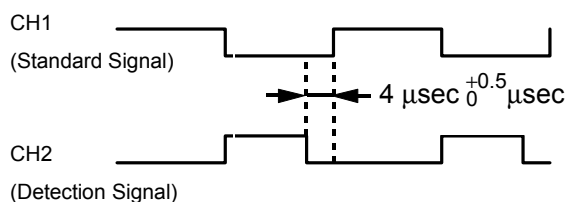

**Purpose:** To ensure correct detection of a no ink condition when all the ink has been consumed.

1. Remove the rear cover of the machine.
2. Position SW901 [A] on the ink detecting board to the oil type (upper) position.
3. Connect the CH1 probe of an oscilloscope to TP1, the CH2 probe to TP2 and the GND lead to TP-12V. Select the 5 microsecond range.
4. Install a drum with no ink or remove the ink cartridge and make prints until the Add Ink is displayed (the ink detecting pin is not in contact with the ink).
5. Make sure that the waveform is as shown above when the ink detecting pin is not in contact with the ink.
  - This adjustment should be made under normal conditions (20°C/65% RH).

**NOTE:** The period of the waveform varies inversely with temperature.  
(High temp. → reduced period. Low temp. → increased period)

6. If incorrect, adjust the ON timing of the detection signal using VR901 [B] on the ink detecting board.

## 9.14 SCREEN REPLACEMENT

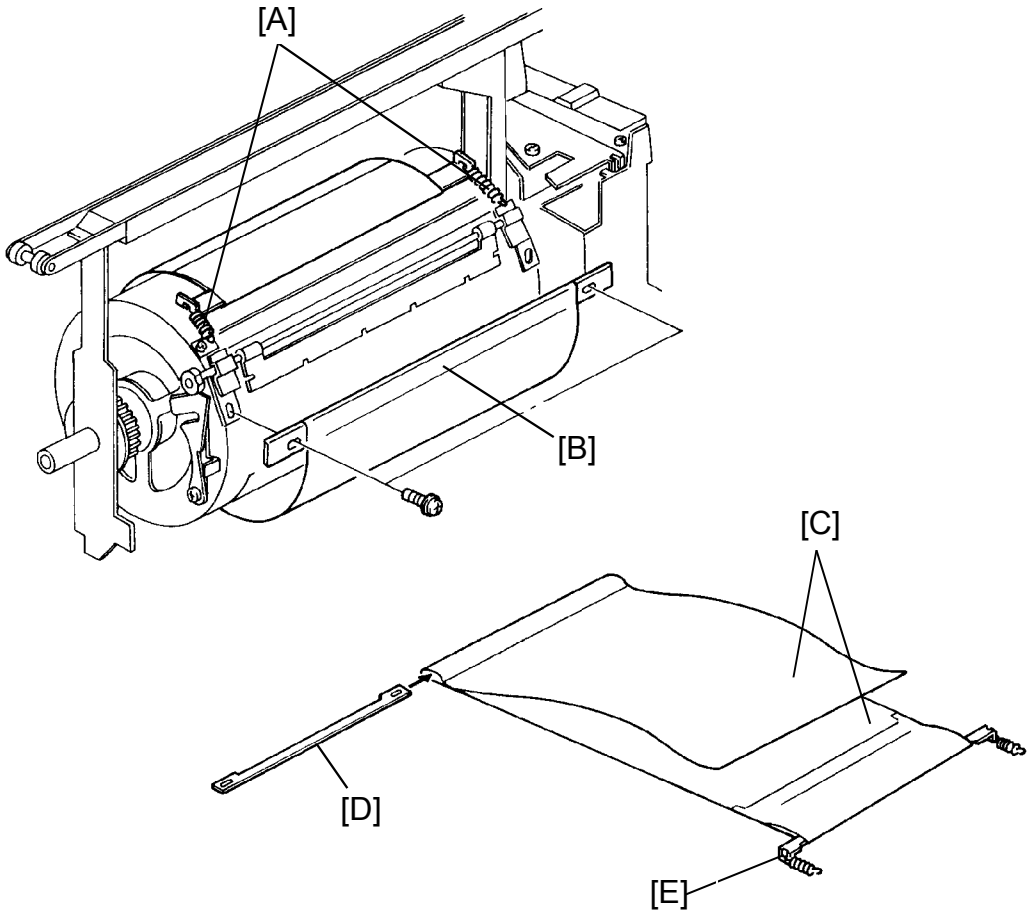

1. Remove the drum unit from the machine.
2. Remove the 2 springs [A].
3. Remove the front screen plate [B] (2 screws).
4. Remove the tetron screens [C] from the drum.
5. Remove the front screen plate [D] and the rear screen plate [E].

## 9.15 DRUM DRIVE BELT REPLACEMENT

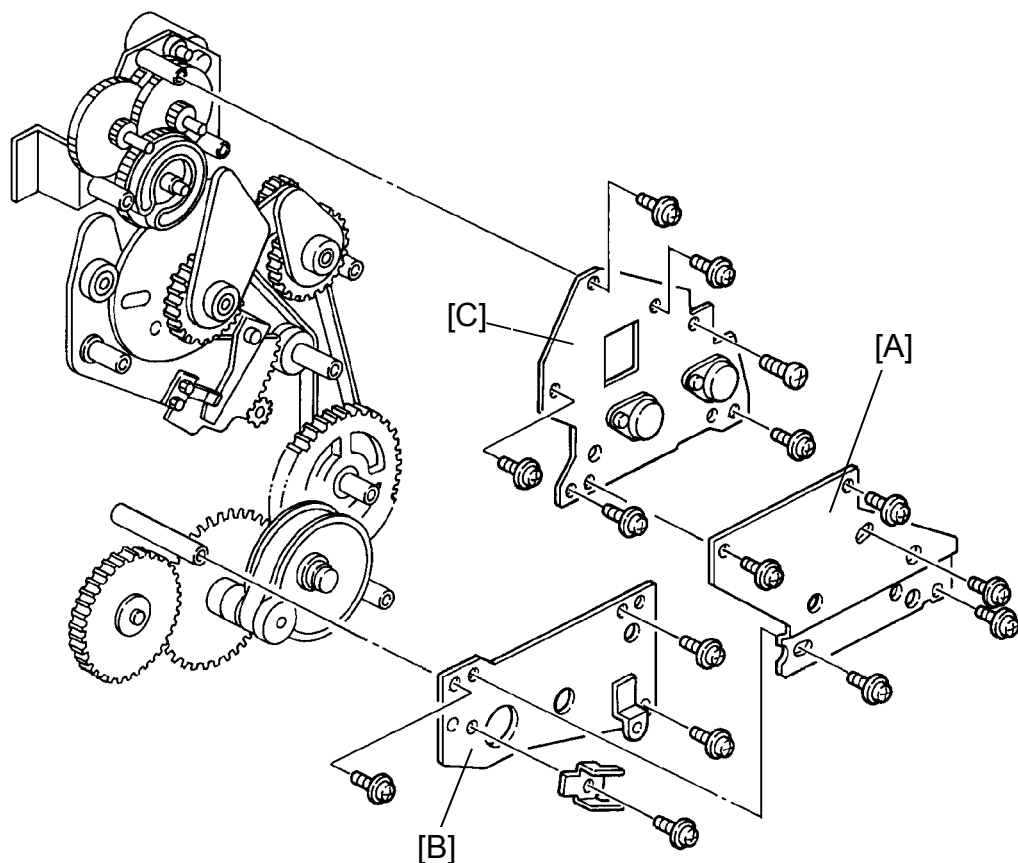

## Removal:

1. Set the image position to "0" by turning off and on the main switch.
2. Turn off the main switch and unplug the power supply cord.
3. Remove the drum unit.
4. Remove the rear cover.
5. Remove the center support side plate [A] (5 screws).
6. Remove the lower support side plate [B] (4 screws).
7. Remove the upper support side plate [C] (6 screws).

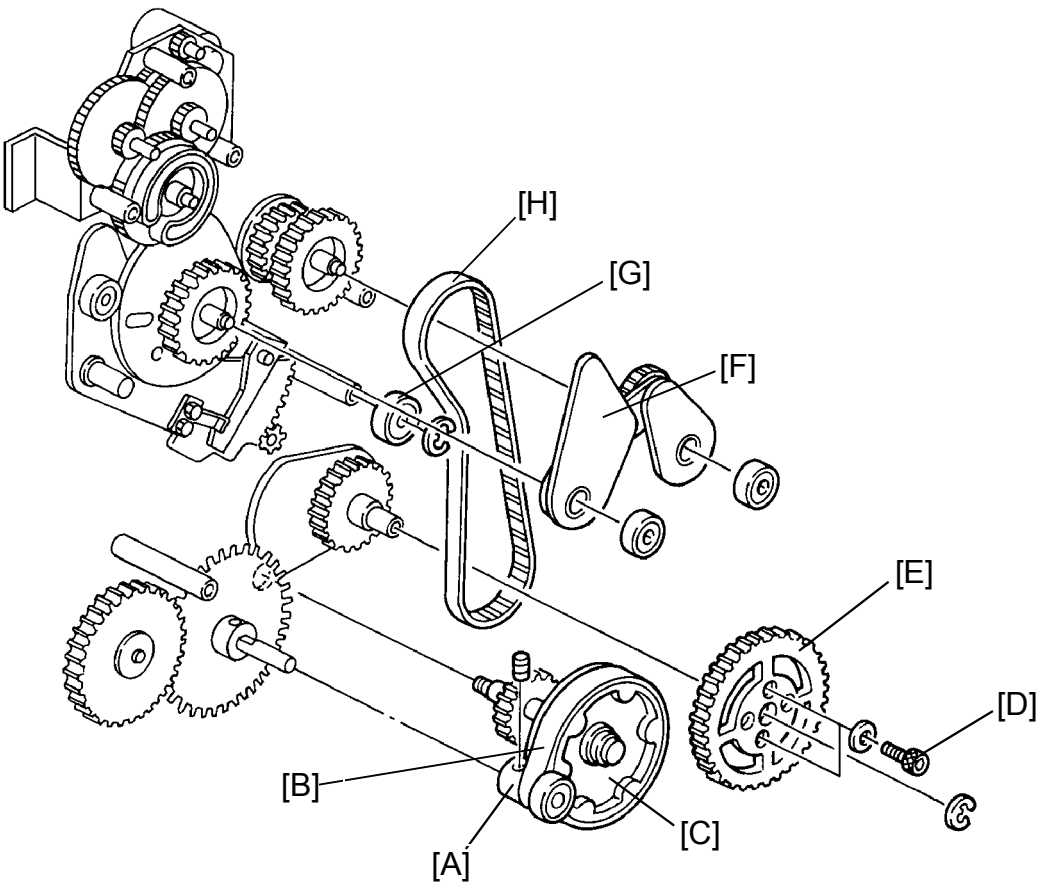

VT2100/2130/2150 Only:

8. Remove the drive gear [A] and the bearing (2 Allen screws).

NOTE: It is not necessary to remove the drive gear on the VT2300 and the VT2500 because these models use a timing relay belt [B].

9. Remove the relay gear assembly [C].

10. Loosen the 2 hexagon bolts [D] and remove the pressure cam drive gear [E].

11. Remove the timing gear assembly [F].

12. Remove the belt tension bearings [G] (1 E-ring).

13. Replace the drum drive belt [H].



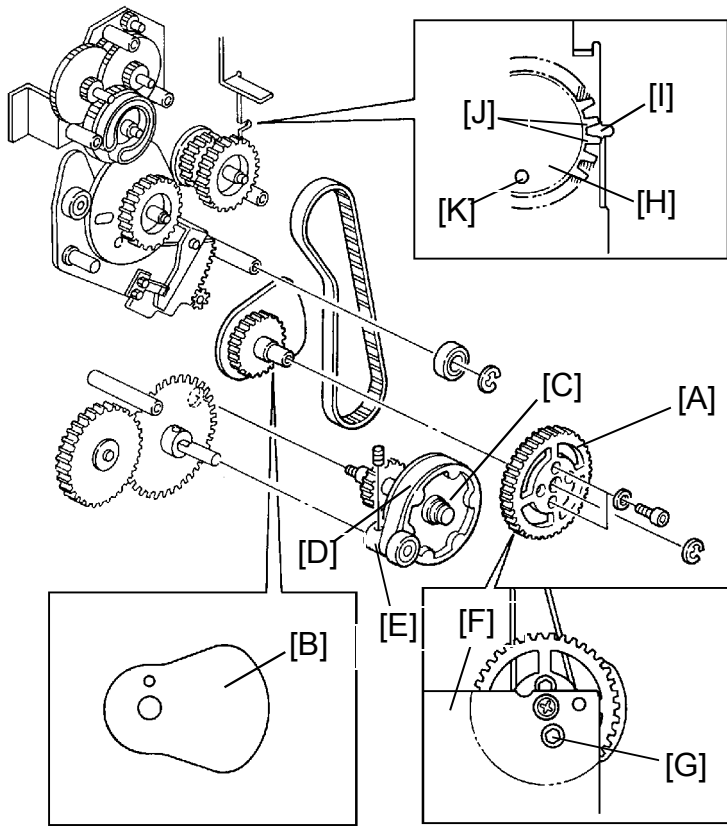

### Assembly:

1. Install the pressure cam drive gear [A].

NOTE: Make sure that the top part of the pressure cam points to the right [B].

2. Install the relay gear assembly [C].

3. Install the relay belt [D] (VT2300/VT2500 only).

4. Install the drive gear [E] (VT2100/VT2130/VT2150 only).

5. Install the lower support side plate [F].

6. Adjust the drum drive belt position so that the hexagon bolt [G] can be seen through the hole in the lower support side plate when the drum drive gear [H] is at drum home position. (The notch cut in the plate [I] lines up with the gap between the two teeth [J] on the drum drive gear. Also, the hole [K] in the drum drive gear lines up with a hole in the rear side plate → Check by inserting a long screwdriver.)

NOTE: These are the only teeth on the drum drive gear that are not backed by the metal plate on the rear side of the drum drive gear.

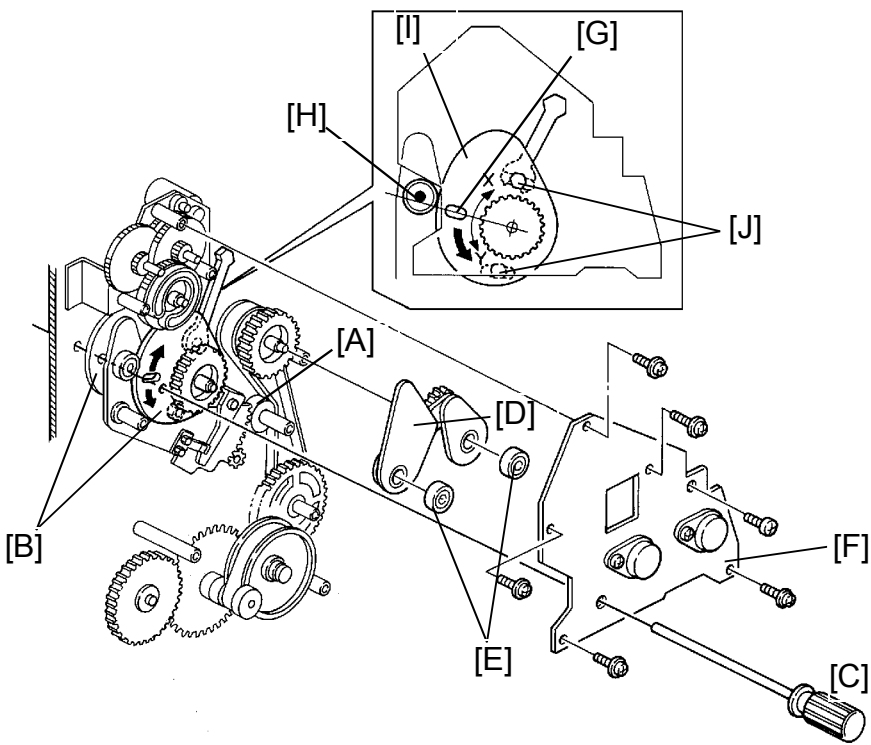

7. Install the belt tension bearings [A] (1 E-ring).
  8. Adjust the position of both feed cams [B] by inserting a long screwdriver [C] as shown through the holes in the feed cams and the rear side plate.
  9. Install the timing gear assembly [D] with the two bearings [E].
  10. Install the upper support side plate [F].
  11. Confirm the position of the cams by inserting a long screwdriver as shown through the holes in the upper support side plate, the feed cams, and the rear side plate.
  12. Confirm that the center of the slot [G] in the second feed cam is aligned with the lower side of the bearing shaft [H].
- NOTE: Push down lightly on the second feed cam to remove any play in the cam gear.
13. Make prints to check the registration.
  14. If the registration is off by more than 9 mm, repeat steps 8 to 13. If the registration is only off by a few millimeters, loosen the two bolts [J] with a spanner (8 mm) and adjust the second feed cam position.  
 X direction: Image on the prints is shifted up.  
 Y direction: Image on the prints is shifted down
  15. Install the center support side plate.

## 10. PAPER DELIVERY

### 10.1 FIRST PAPER EXIT SENSOR ADJUSTMENT

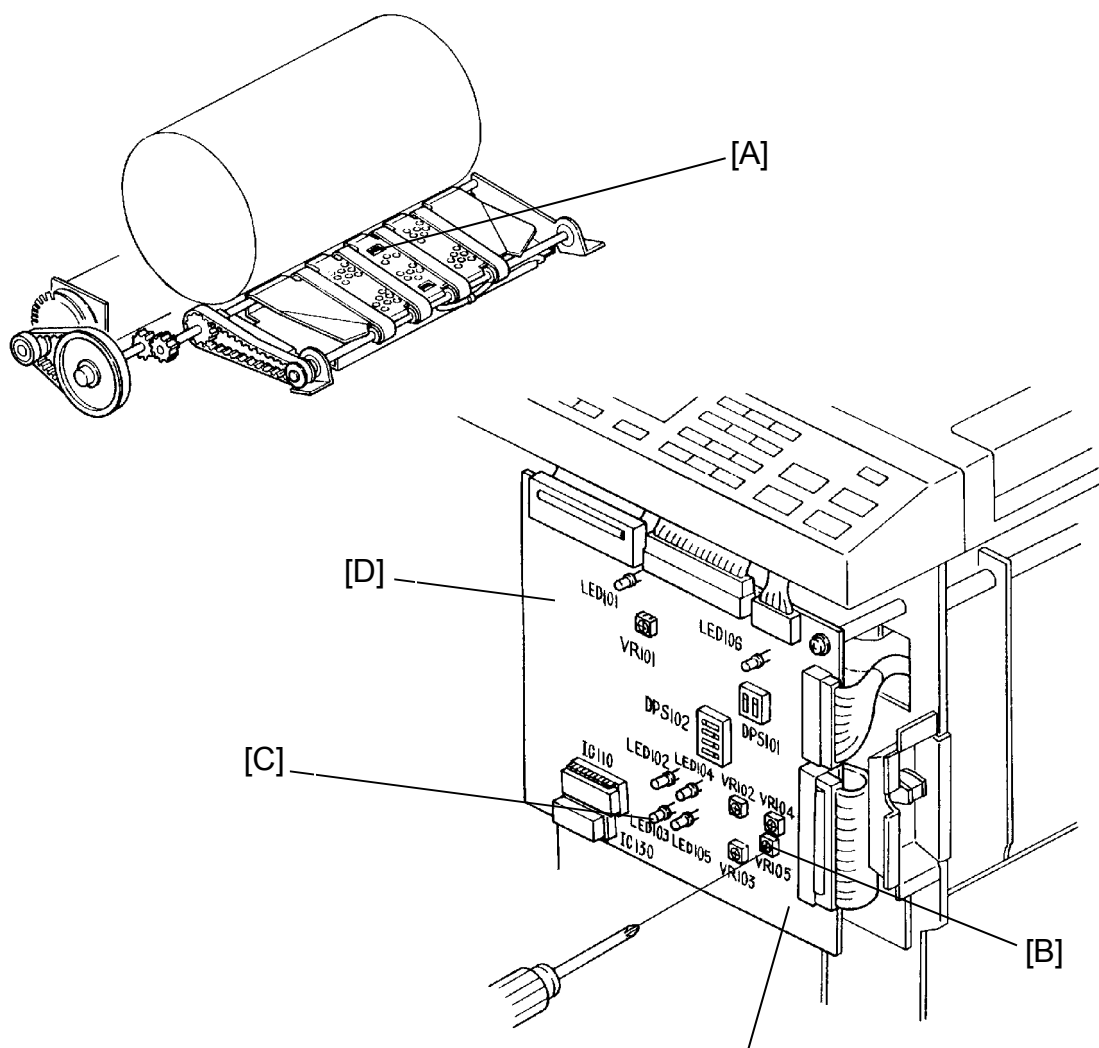

VT2300/VT2500 Main Control Board

Purpose : To ensure that the sensor detects correct paper delivery and that the jam indicator blinks after an exit misfeed or a paper wrap occurs.

1. Remove the front cover from the machine.
2. Place a sheet of 65 g/m<sup>2</sup> paper 30 mm above the first paper exit sensor [A] and make sure that VR105 [B] for VT2300/VT2500 (VR102 for VT2100/VT2130/VT2150) is set to the ON/OFF threshold of LED 103 [C].
3. If incorrect, adjust the sensor sensitivity by turning VR105 for VT2300/VT2500 (VR102 for VT2100/VT2130/VT2150) on the main control board [D].

## 10.2 SECOND PAPER EXIT SENSOR ADJUSTMENT

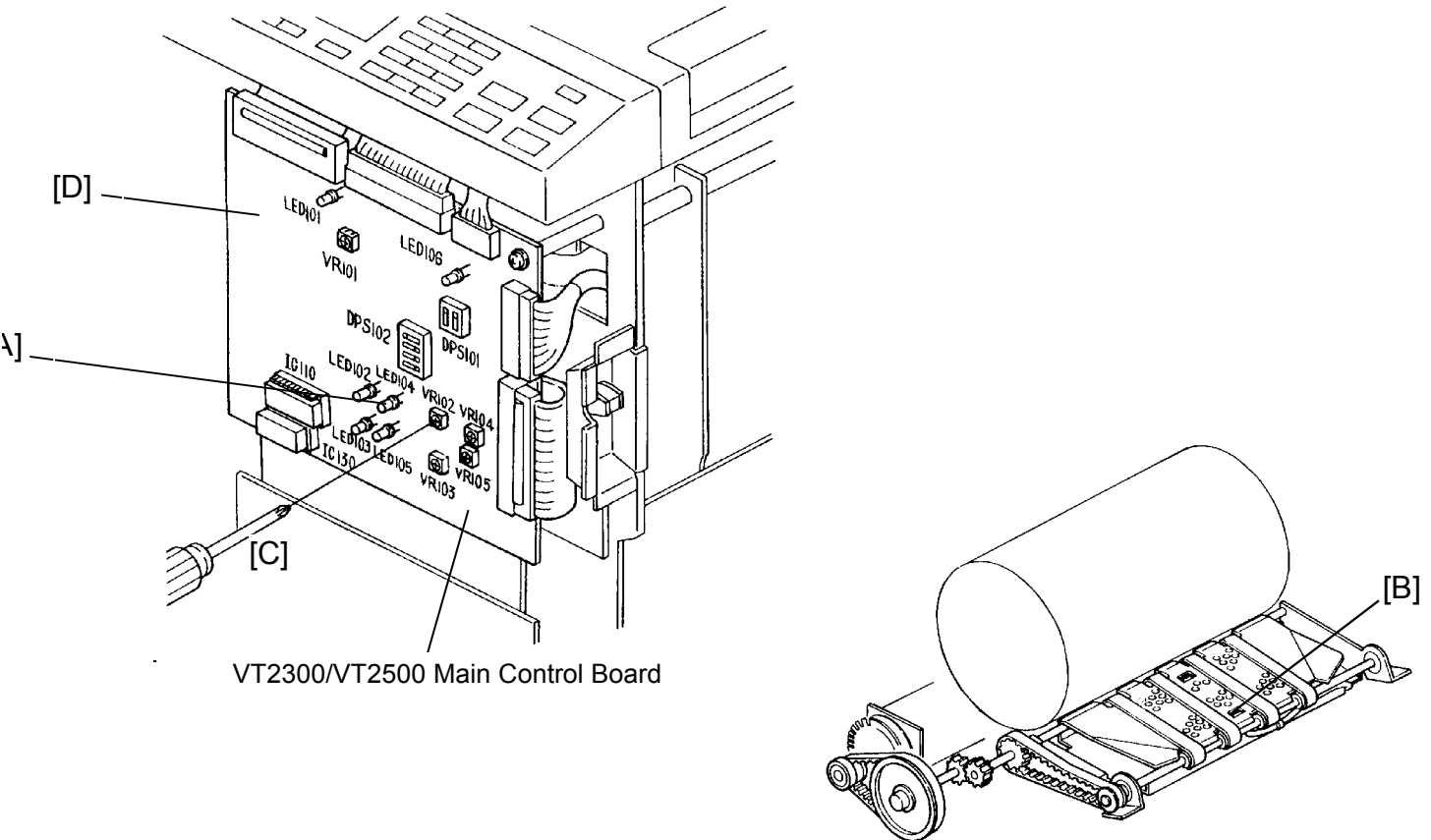

**Purpose :** To ensure that the sensor detects correct paper delivery and that the jam indicator blinks and the machine stops when a paper wrap or exit misfeed occurs

1. Remove the front cover from the machine.
2. Confirm the following items:
  - a. When the shelter plate is removed and the master eject unit is closed, LED104 [A] for VT2300/VT2500 (LED101 for VT2100/VT2130/VT2150) is OFF.
  - b. When the shelter plate is installed and the master eject unit is closed, LED104 [A] for VT2300/VT2500 (LED101 for VT2100/VT2130/VT2150) is OFF.
  - c. When a sheet of paper is positioned over the second paper exit sensor [B] and is in contact with the shelter plate, LED104 for VT2300/VT2500 (LED101 for VT2100/VT2130/VT2150) is ON.
3. If any of the above items is incorrect, adjust the sensor by turning VR102 [C] for VT2300/VT2500 (VR101 for VT2100/VT2130/VT2150) on the main control board [D].

## 10.3 EXIT PAWL CLEARANCE ADJUSTMENT

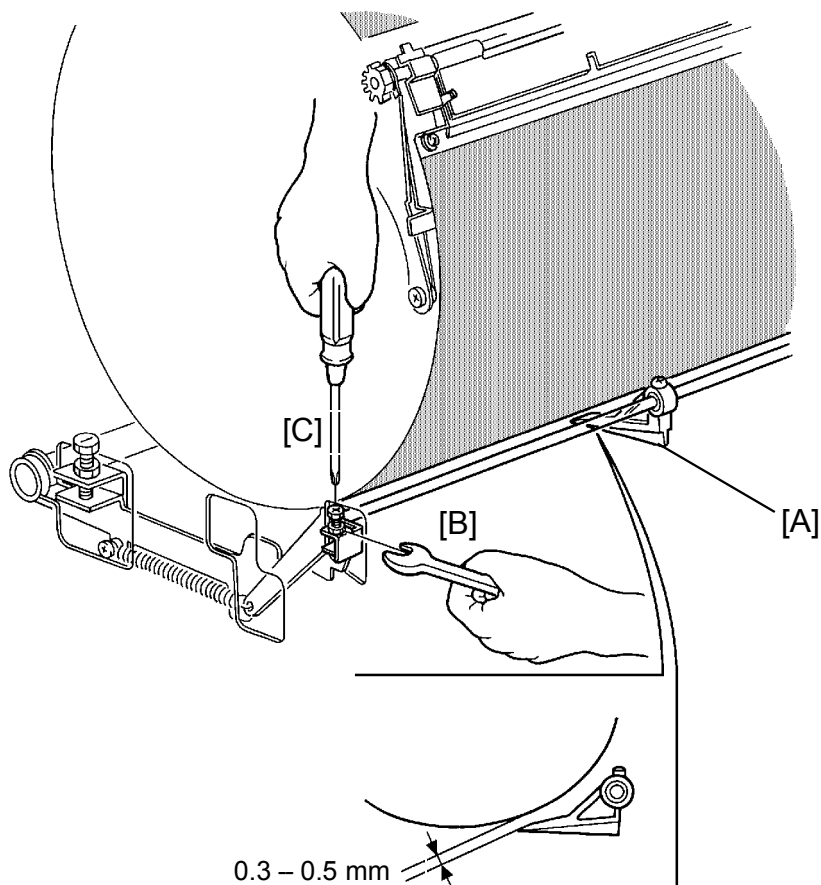

**Purpose:** To ensure that the printing paper is delivered without paper wrap or damage to the screen.

1. Remove the rear cover of the machine.
2. Manually turn on the paper feed and the printing pressure solenoids. Using a spanner (10 mm), gradually rotate the drum rotation shaft counterclockwise to move the exit pawl [A] to the drum.
3. Make sure that the clearance between the drum and the exit pawl is 0.3 to 0.5 mm when the exit pawl is at the position closest to the drum.
4. If incorrect, open the master eject box and loosen the hexagon nut [B] of the exit pawl drive arm. Then adjust the clearance by turning the screw [C].
5. Check adjustment by repeating steps 2 and 3.

## 10.4 EXIT PAWL TIMING ADJUSTMENT

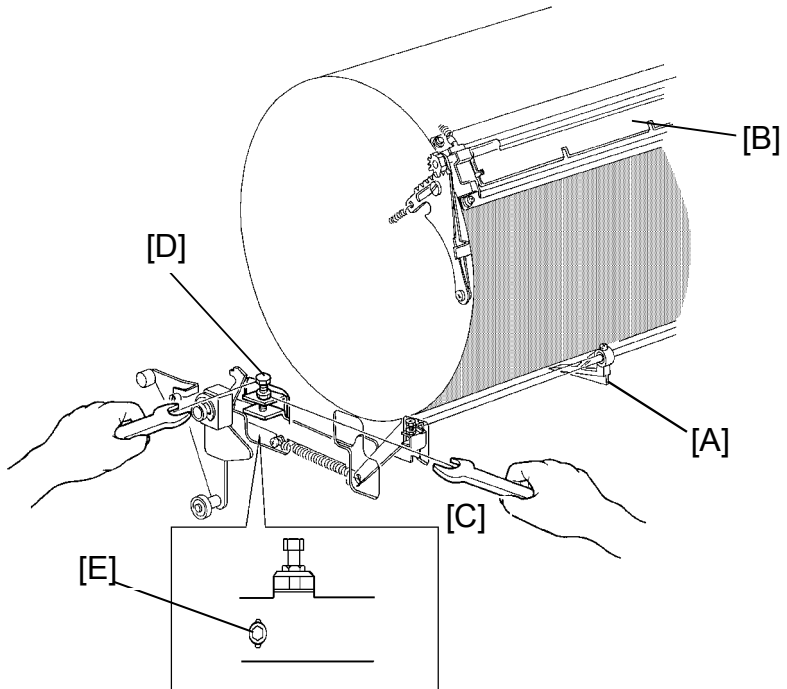

Purpose: To ensure that the exit pawl does not contact the master clamber.

1. Remove the rear cover of the machine.
2. Press the Image Shifting key to give a maximum white area at the paper leading edge (image shift position set to "-2").
3. Stack 65 g/m<sup>2</sup> paper on the paper table.
4. Access I/O Check mode (See page 4-11).
  - Enter "0" in the memory display and "4" in the copy counter.
5. Press the Print Start key to raise the paper table to the correct position.
6. Manually turn on the paper feed and the printing pressure solenoids. Using a spanner (10 mm), gradually rotate the drum rotation shaft counterclockwise at a constant speed.
7. While rotating, make sure that the exit pawl [A] does not contact the master clamber [B] and that the exit pawl approaches the drum before the leading edge of the printing paper exits.
8. If incorrect, loosen the hexagon nut [C] and hexagon bolt [E] and adjust the exit pawl position by turning the hexagon bolt [D].
9. Check adjustment by repeating step 7 with the image position shifted to both maximum forward and maximum backward directions.

## 10.5 DELIVERY TABLE REPLACEMENT

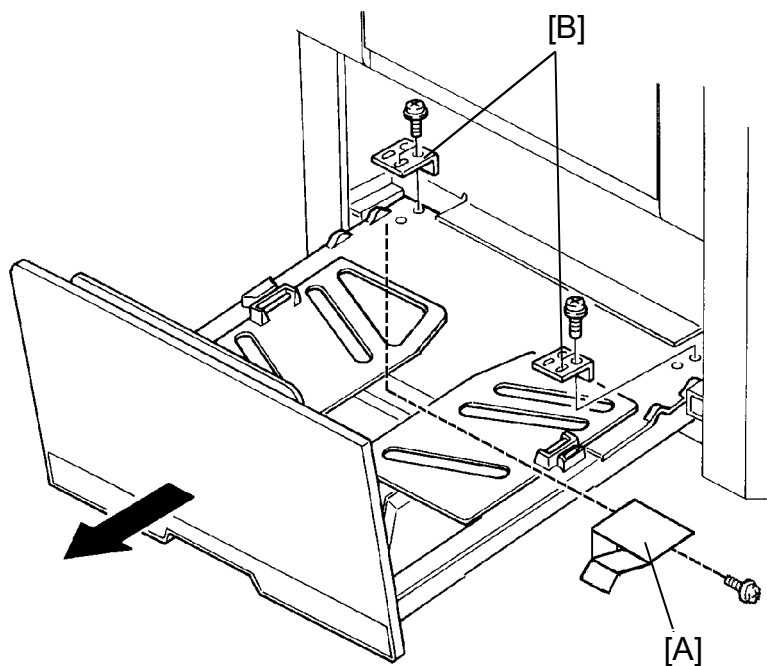

1. Open the delivery table.
2. Remove the leaf spring [A] for GND located under the table (1 screw)
3. Remove the stoppers [B] (2 screws each).
4. Remove the delivery table.

## 10.6 VACUUM UNIT REPLACEMENT

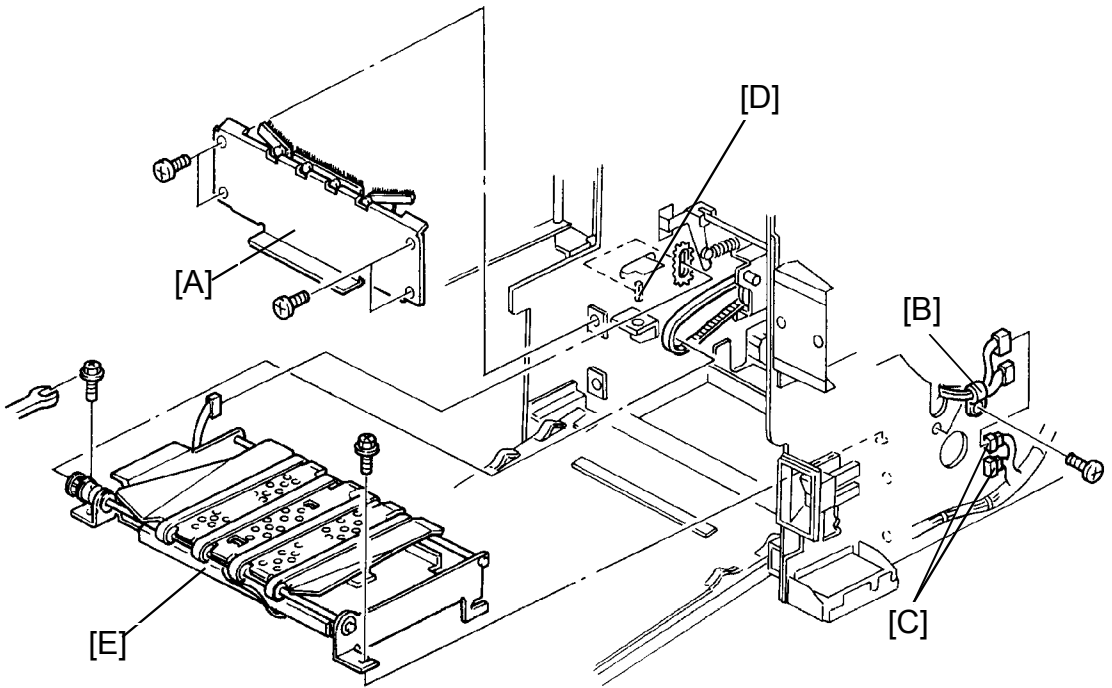

1. Remove both front and rear covers of the machine.
2. Remove the antistatic brush bracket [A] (4 screws).
3. Remove the harness clamp [B] (1 screw).
4. Disconnect the sensor connectors [C].
5. Disconnect the vacuum motor connector [D].
6. Remove the vacuum unit [E] (2 screws).



## 10.7 DELIVERY BELT/PAPER EXIT SENSORS REPLACEMENT

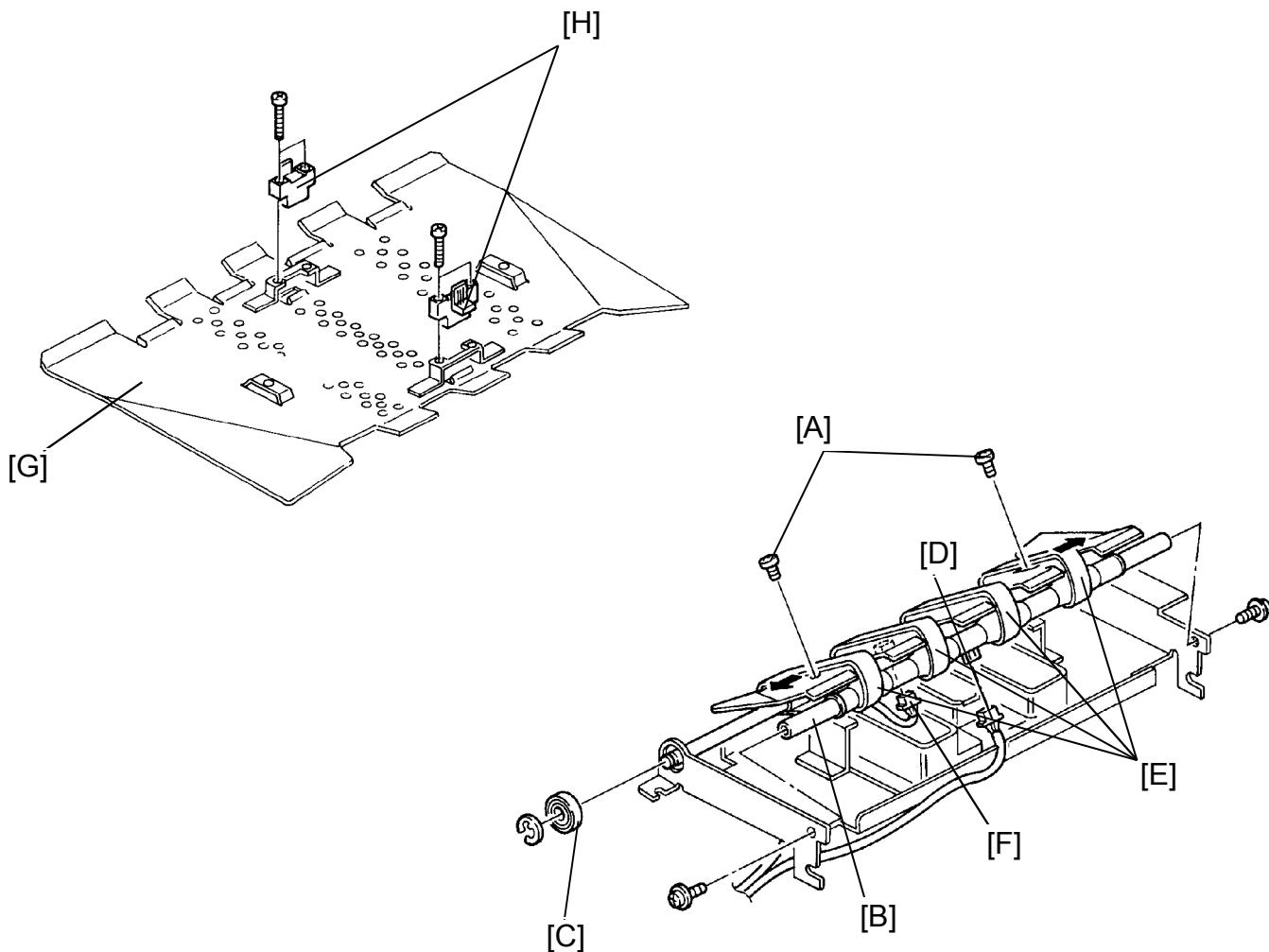

1. Remove the vacuum unit (See page 5-83).
2. Remove the 2 screws [A] securing the vacuum guide plate.
3. Remove the tension roller [B] (2 screws).
4. Remove the bearing [C] (1 E-ring).
5. Disconnect the first paper exit sensor connector [D].
6. Remove the delivery belts [E].
7. Disconnect the second paper exit sensor connector [F].
8. Turn the vacuum guide plate [G] over.
9. Replace the paper exit sensors [H] (2 screws each).

## 10.8 VACUUM MOTOR REPLACEMENT

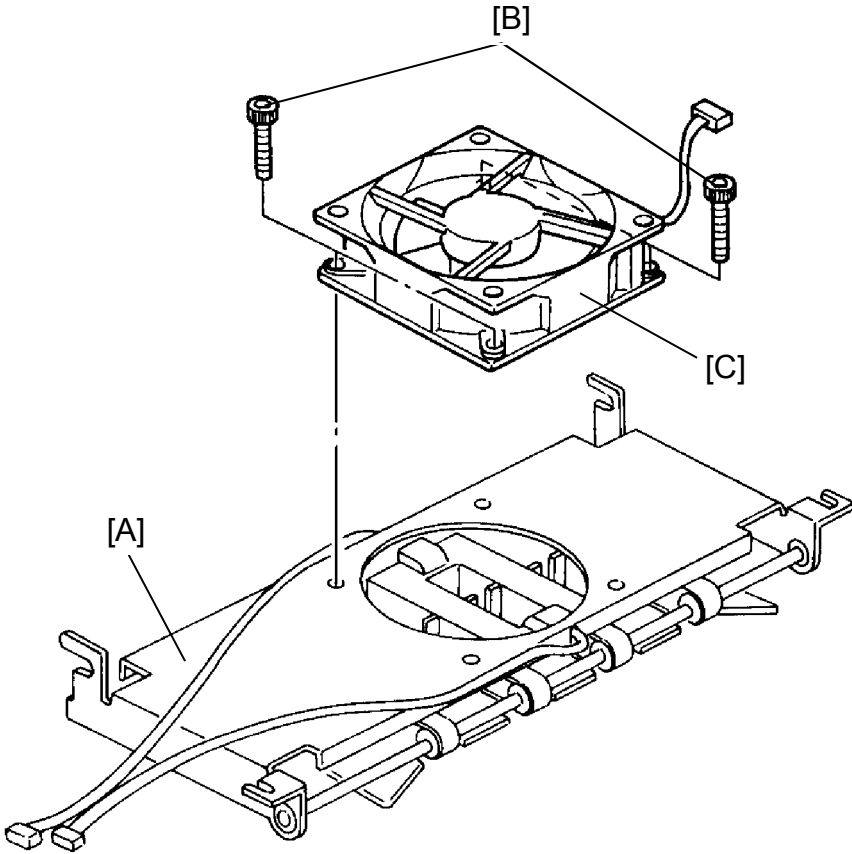

















1. Remove the vacuum unit (See page 5-83).
2. Turn the vacuum unit [A] over.
3. Loosen the 4 hexagon bolts [B].
4. Remove the vacuum motor [C].













# SECTION 7



# TROUBLESHOOTING

# 1. ELECTRICAL COMPONENT TROUBLE



Component	Condition	Phenomenon	
10 A Fuse (Power Supply PCB)	Open	Machine does not work. (No indicators on the operation panel turn on.)	
2.5 A Fuse (AC Drive PCB)	Open	Cover open indicator blinks when the main switch is turned on.	
+24 V (CN510-1 on Power Supply PCB)	No output	Buzzer sounds and the machine does not work.	
+24 V (CN504-1 on Power Supply PCB)	No output	Nothing happens when the main switch is turned on; when the Master Making key is pressed, the master feed motor fails to turn on and the "C" and  jam indicators blink.	
+24 V (CN504-2 on Power Supply PCB)	No output	Nothing happens when the main switch is turned on; when the Master Making key is pressed, the master feed motor fails to turn on and the "C" and  jam indicators blink.	
SEOH (CN503-1 on Power Supply PCB)	No output	When the main switch is turned on, E04 is displayed.	
+12 V (CN503-2 on Power Supply PCB)	No output	Machine functions are correct, but the image is almost completely black.	
+12 V (CN503-3 on Power Supply PCB)	No output	Counter indicator is not displayed. (Only the reduction and image mode indicators are displayed.)	
-12 V (CN503-4 on Power Supply PCB)	No output	Machine functions are correct, but the image is almost completely black. When the Print Start key is pressed, the add ink indicators  and "D" blink after 20 rotations even though ink is present.	
+5 V (CN503-5 on Power Supply PCB)	No output	Nothing happens	There is no output at Pins 5 and 6, and the drum rotates at high speed after the main switch is turned on.
+5 V (CN503-6 on Power Supply PCB)	No output	Nothing happens	
+12 V (CN103-2 on Main PCB)	No input	Counter indicator is not displayed (Only the reduction and image mode indicators are displayed.)	
+5 V (CN103-3 on Main PCB)	No input	No indicators turn on.	
-12 V (CN103-6 on Main PCB)	No input	Machine functions are correct, but when the Print Start key is pressed, the add ink indicators  and "D" blink after 20 rotations even though ink is present.	
1st Original Sensor (VT2300/VT2500 Only)	ON condition (Not interrupted)	First original can be printed correctly, but the jam indicators "A" and  blinks during the next master process when the ADF drive motor turns on.	
	OFF condition (Interrupted)	When the Master Making key is pressed, the jam indicators "A" and  blinks.	

Component	Condition	Phenomenon
2nd Original Sensor	ON condition (Not interrupted)	When the main switch is turned on, the jam indicators "A" and  blink and reset is impossible.
	OFF condition (Interrupted)	The original is not inserted automatically, and the jam indicators "A" and  blink when the Master Making key is pressed (VT2100/2130/2150). The original is fed when the Master Making key is pressed, but the leading edge of the original is damaged because the original transport motor fails to turn on. The "A" and  jam indicators blink (VT2300/VT2500).
Original Registration Sensor	ON condition (Not interrupted)	After the master making process is finished, the Jam indicators "A" and  blink.
	OFF condition (Interrupted)	The original is fed until the leading edge of the original goes 5 cm past the exposure glass, then jam indicators "A" and  blink.
Master Eject Switch (Sensor)	ON condition (Not interrupted)	After the master is ejected and one sheet of paper (trial print) is delivered, the jam indicators "F" and  blink and reset is impossible.
	OFF condition (Interrupted)	When the master is being ejected, the jam indicators "F" and  blink.
Pressure Plate Position Switch	ON condition (Feeler is actuated)	The pressure plate does not go up. After one sheet of paper (trial print) is delivered, the indicators "F" and  blink.
	OFF condition (Feeler is not actuated)	When the main switch is turned on, the pressure plate keeps moving up and down.
Full Master Detecting Switch	ON condition (Feeler is actuated)	When the master eject box is full, the indicators "F" and  do not blink.
	OFF condition (Feeler is not actuated)	After master ejecting is finished, the indicators "F" and  blink.
Paper Table Lower Limit Sensor	ON condition (Interrupted)	The paper table does not go down.
	OFF condition (Not interrupted)	When the paper feed table goes down and stops, the cover open indicator blinks.
Paper Table Safety Switch	ON condition (Feeler is actuated)	When the main switch is turned on, the cover open indicator blinks.
	OFF condition (Feeler is not actuated)	If paper table lower limit sensor is faulty, the paper table moves all the way down and locks.

Component	Condition	Phenomenon
Paper Table Height Sensor	ON condition (Interrupted)	When the paper feed table goes up, it does not stop at the proper position and E-02 lights.
	OFF condition (Not interrupted)	The paper feed table does not go up. When printing starts, jam indicators "B" and  blink.
Paper End Sensor	ON condition (Not interrupted)	When there is no paper on the paper feed table, the Print Start key can be activated, but jam indicators "B" and  blink.
	OFF condition (Not interrupted)	Though there is paper on the paper table, paper end indicators "B" and  blink.
Pressure Sensor	ON condition (Interrupted)	After one sheet of paper is printed, the machine stops. At that time, the counter does not count down and jam indicators "B" and  blink.
	OFF condition (Not interrupted)	When the main switch is turned on, jam indicators "B" and  blink and cannot be reset.
First Paper Exit Sensor	ON condition (Paper exists)	When the main switch is turned on, the machine stops and jam indicators "G" and  blink.
	OFF condition (Paper does not exist)	After one sheet of paper is printed, the machine stops and jam indicators "B", "E", and  blink.
Second Paper Exit Sensor	ON condition (Paper exists)	When the main switch is turned on, jam indicators "G" and  blink.
	OFF condition (Paper does not exist)	After one sheet of paper is printed, the machine stops and jam indicators "E" and  blink.
Paper Feed Solenoid	OFF condition	The paper is not fed and jam indicators "B" and  blink.
Drum Rotation Sensor	ON condition (Interrupted)	The drum begins to rotate when the main switch is turned on. E06 lights when the Master Making key is pressed or when the Print Start key is pressed.
	OFF condition (Not interrupted)	The drum begins to rotate when the main switch is turned on. E06 lights when the Master Making key is pressed or when the Print Start key is pressed.
Master End Sensor	ON condition (Actuated)	Normal operation when master is present. Master end is not detected; Master End indicators "C" and  do not blink and jam indicators "C" and  blink.
	OFF condition (Not actuated)	Even if the master is present, the Master End indicators "C" and  blink.

Component	Condition	Phenomenon
Right Cutter Switch (Rear)	ON condition (Feeler is actuated)	Master is not cut. (Cutter unit does not move at all.)
	OFF condition (Feeler is not actuated)	When the master is cut, indicator "E-01" lights. At that time the cutter does not return to the front.
Left Cutter Switch (Front)	ON condition (Feeler is actuated)	Master is not cut. (Cutter unit does not return from the rear.)
	OFF condition (Feeler is not actuated)	When the main switch is turned on, indicator "E-01" lights.
First Drum Position Sensor	OFF condition (Not interrupted)	When the main switch is turned on, the drum starts rotating and it cannot be stopped.
	ON condition (Interrupted)	<p>* Print (When the Print Start key is pressed)</p> <ol style="list-style-type: none"> <li>1. After one sheet of paper is fed, the drum continues to rotate and paper feed stops.</li> <li>2. The machine does not stop when the Stop key is pressed.</li> <li>3. Paper feed and delivery jams are not detected.</li> </ol> <p>* Master making (When the Master Making key is pressed)</p> <ol style="list-style-type: none"> <li>1. After the new master is wrapped around the drum and one sheet of paper (trial print) is delivered, the drum does not stop rotating. The Stop key does not work.</li> </ol>
Second Drum Position Sensor	OFF condition (Not interrupted)	<p>* Print (When the Print Start key is pressed)</p> <ol style="list-style-type: none"> <li>1. The paper feed solenoid does not work and the Stop key does not work.</li> </ol> <p>* Master making (When the Master Making key is pressed)</p> <ol style="list-style-type: none"> <li>1. When the Master Making key is pressed, the drum starts rotating and cannot be stopped.</li> </ol>
	ON condition (Interrupted)	<p>* Print (When the Print Start key is pressed.)</p> <ol style="list-style-type: none"> <li>1. Paper feed solenoid does not work and drum continues to rotate.</li> </ol> <p>* Idling time (Reset key + 0 key)</p> <ol style="list-style-type: none"> <li>1. Drum does not stop rotating.</li> </ol> <p>* Master eject</p> <ol style="list-style-type: none"> <li>1. When the Master Making key is pressed, master eject indicators "F" and  blink and the master is not ejected.</li> </ol>
Master Buckle Sensor	ON condition	When the main switch is turned on, jam indicators "C" and  blink and cannot be reset.
	OFF condition	Original feeding and master feeding stops halfway, and jam indicators "C" and  blink.

## VT2300/VT2500 only:

Component	Condition	Phenomenon
Paper Size Detection Sensor 1	Always ON (Paper detected)	* A4 : Master making length is 247mm (B5 lengthwise). * LT : Master making length is 10.6" (LT lengthwise).
	OFF (Paper not detected)	* A4 : Master making length is 172mm (B5 sideways). * LT : Master making length is 8.1" (HLT lengthwise).
Paper Size Detection Sensor 2	Always ON (Paper exists)	* A4 : Master making length is 172mm (B5 sideways). * LT : Master making length is 8.1" (HLT lengthwise).
	OFF (Paper not detected)	* A4 : Master making length is 247mm (B5 lengthwise). * LT : Master making length is 10.6" (LT lengthwise).
Paper Size Detection Sensor 3	Always ON (Paper detected)	* A4 : Master making length is 172mm (B5 sideways). * LT: Master making length is 8.1" (HLT lengthwise).
	OFF (Paper not detected)	* A4 : Master making length is 287mm (A4 lengthwise). * LT : Master making length is 13.6" (LG lengthwise).
Drum Master Detection Sensor	Always ON (Sensor always detects white)	Master is on the drum: machine works correctly. Master is not on the drum: indicators F and  blink during the master eject process. Printing starts when the Print Start key is pressed, but indicators "E", "B", and  soon turn on and the machine stops.
	OFF (Sensor always detects black)	Master is on the drum: two masters are wrapped on the drum. Master is not on the drum: master is wrapped correctly on the drum, but the "M" indicator blinks when the Print Start key is pressed.

\* Refer to the next page.



## A4 version :

Paper Size Detection Sensor			Image Length (Master Making Length)			
SN1	SN2	SN3	172 mm	247 mm	287 mm	354 mm
OFF	OFF	OFF	0			
ON	OFF	OFF		0		
OFF	ON	OFF	0			
ON	ON	OFF			0	
OFF	OFF	ON	0			
ON	OFF	ON		0		
OFF	ON	ON	0			
ON	ON	ON				0

## LT version :

Paper Size Detection Sensor			Image Length (Master Making Length)			
SN1	SN2	SN3	8.1" (205.9mm)	10.6" (269.4mm)	13.6" (345.6mm)	13.9" (354mm)
OFF	OFF	OFF	0			
ON	OFF	OFF		0		
OFF	ON	OFF	0			
ON	ON	OFF			0	
OFF	OFF	ON	0			
ON	OFF	ON		0		
OFF	ON	ON	0			
ON	ON	ON				0

## 2. TROUBLESHOOTING

### 2.1 IMAGE TROUBLE

#### 1. No image, white lines, uneven image on copy

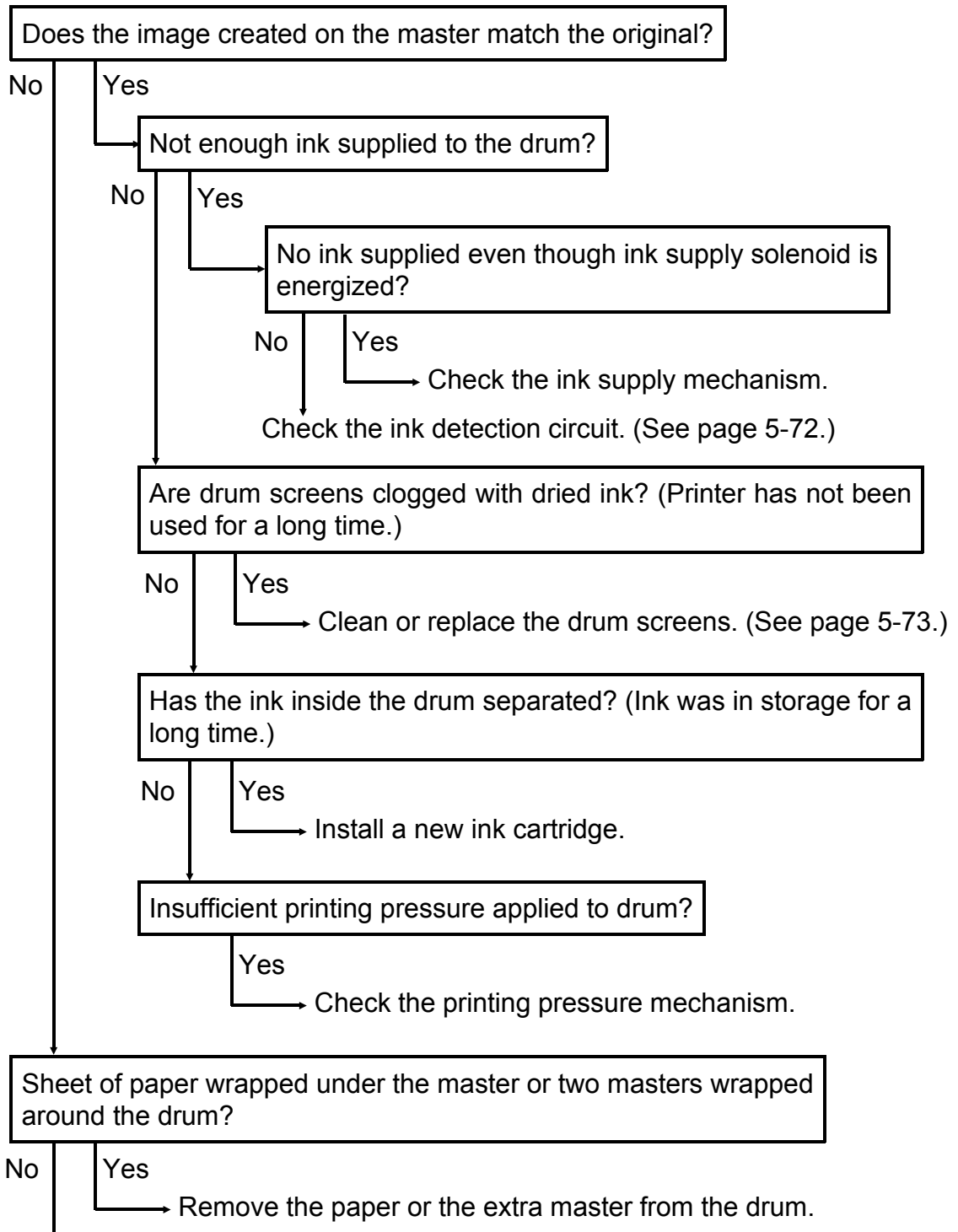

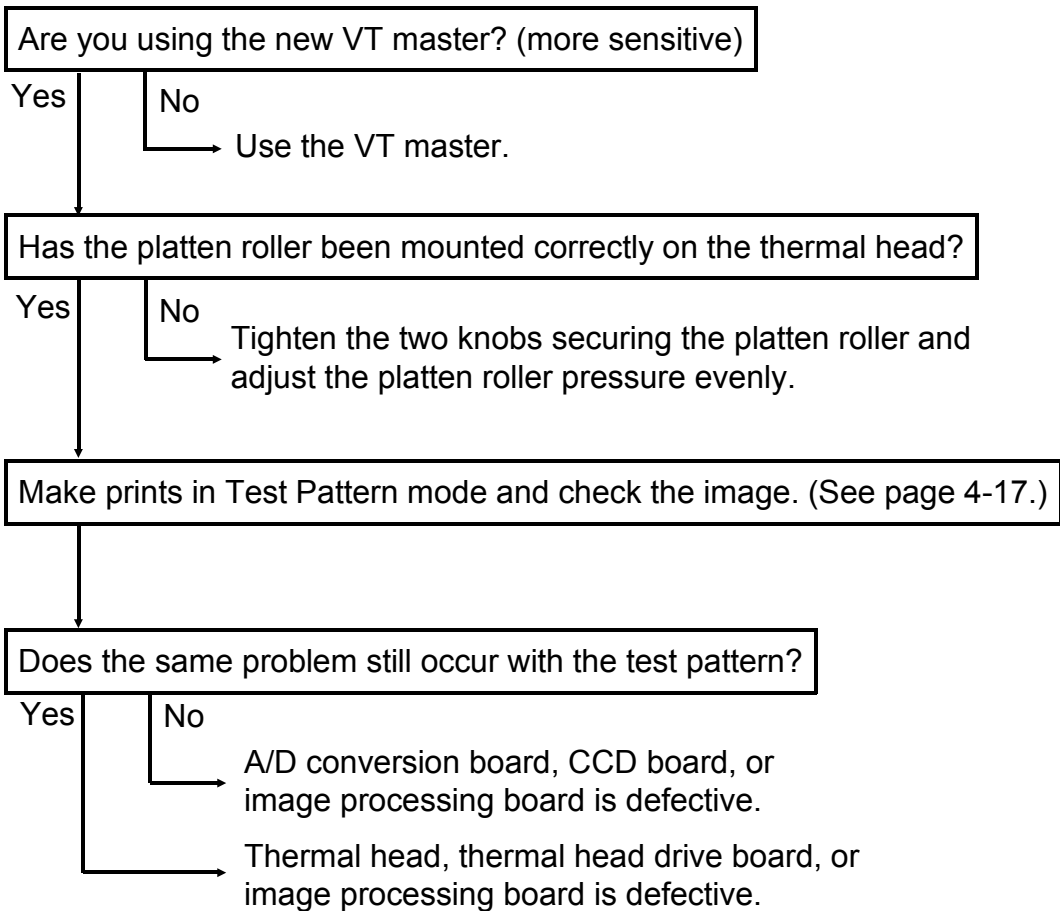

## 2. Print image is enlarged or reduced in the paper feed direction

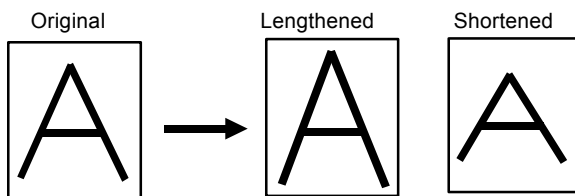

Is the print image larger than the original in the paper feed direction?

No

Yes

Is the original transport motor functioning normally?

Yes

No

Check the original transport motor.

Are the drive belts in the original feed section adjusted to the correct tension?

Yes

No

Adjust the belt tension. (See page 5-3.)

Are any of the pulleys and/or gears in the original feed section loose?

No

Tighten the screws securing the pulleys and/or gears.

Is the print image smaller than the original in the paper feed direction?

Yes

Is the master feed motor functioning normally?

Yes

No

Check the master feed motor.

Are the drive belts in the master feed section adjusted to the correct tension?

Yes

No

Adjust the belt tension. (See page 5-24.)

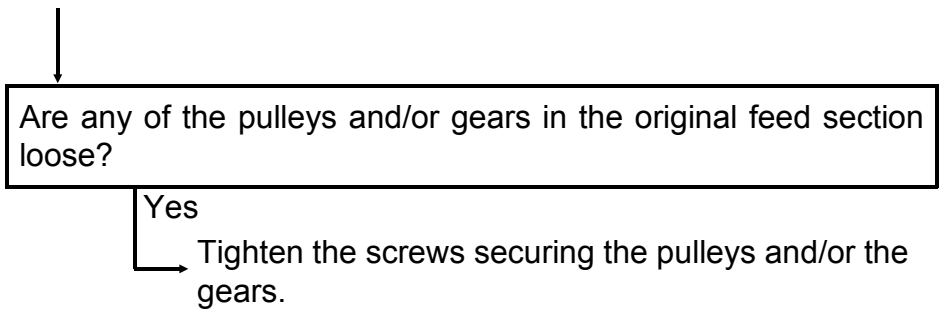

## 2.2 PAPER FEED TROUBLE

### 1. No paper is fed from the paper table.

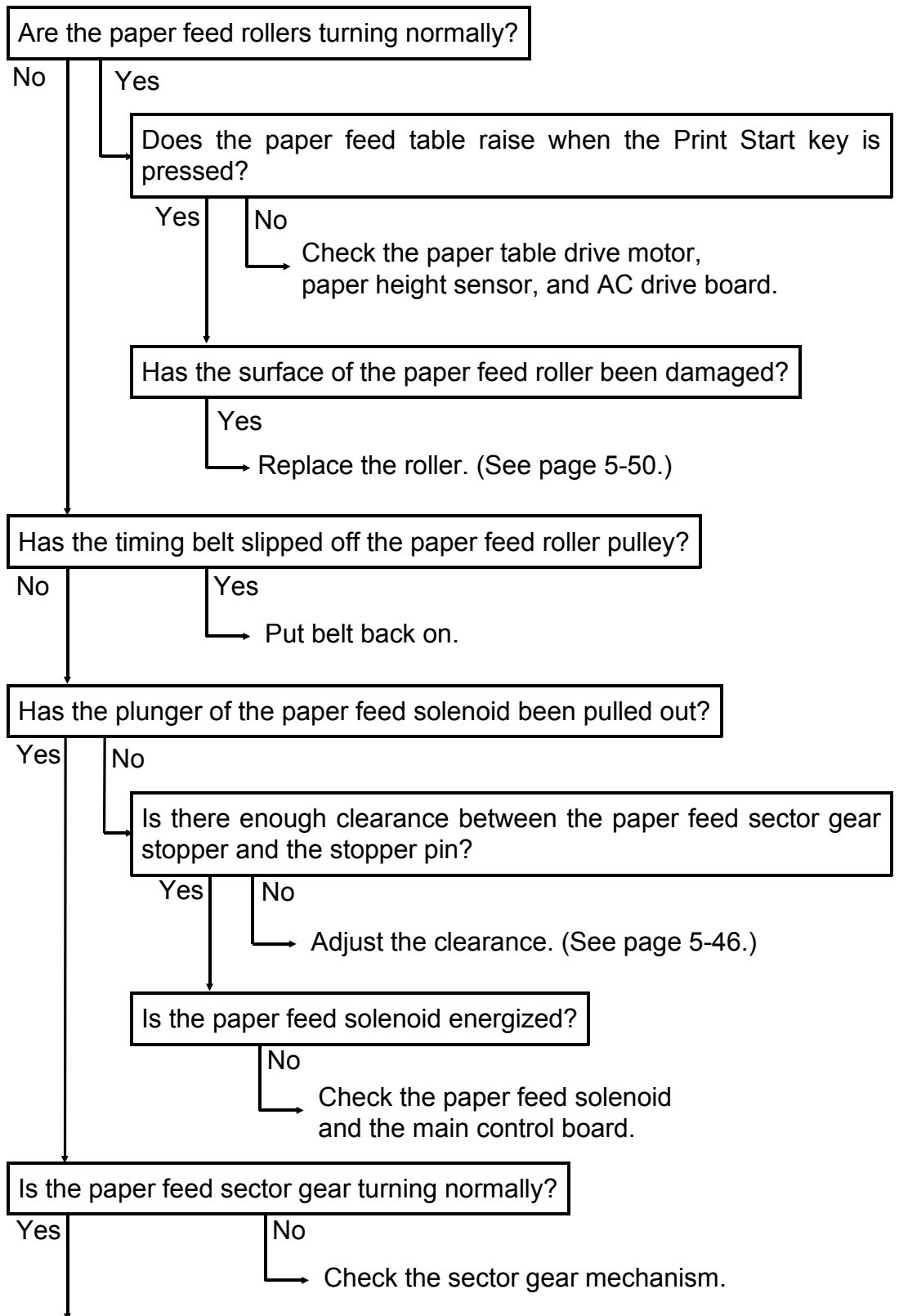



Is the one-way clutch on the paper feed roller shaft slipping? (Paper is often not fed forward at high printing speeds.)



Yes

Lightly sand the roller shaft surface with fine sandpaper (increases the coefficient of friction) and replace the clutch.

## 2. Paper leading edge jams under the second feed roller.

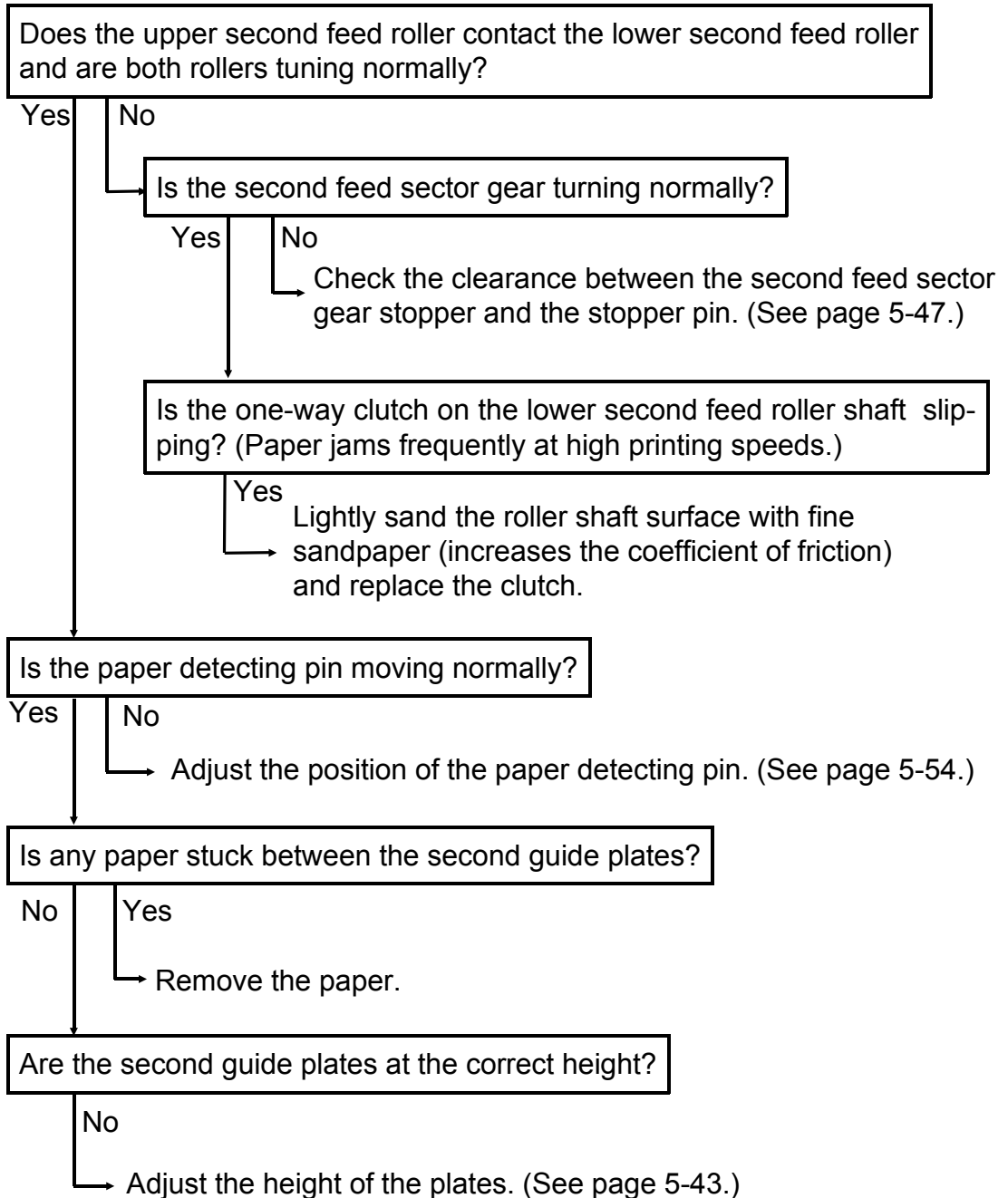



### 3. Paper leading edge jams under the drum.

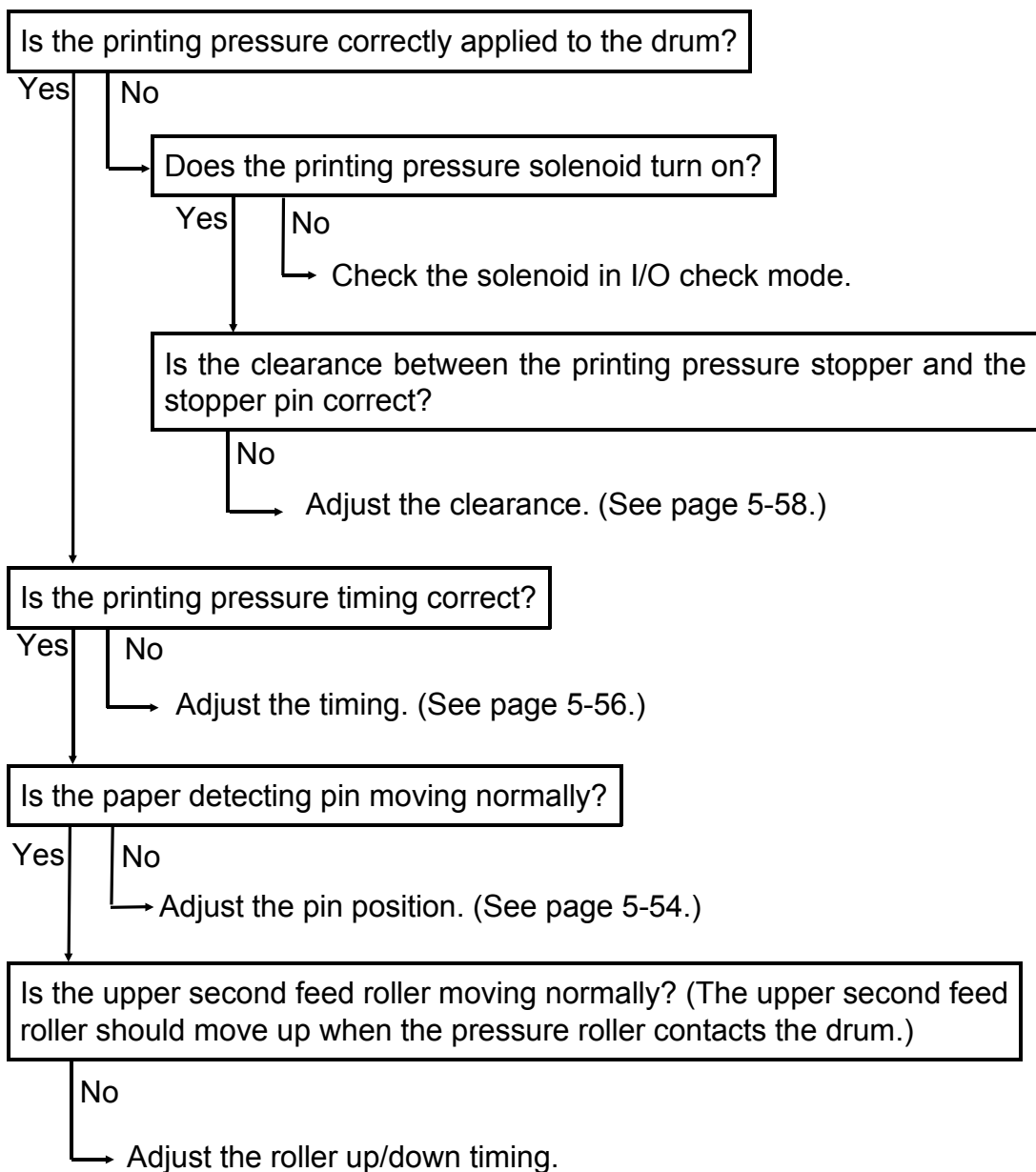

4. Paper frequently jams or is not fed during high speed printing. (Does not occur at low printing speeds.) .

